

PLANET 125

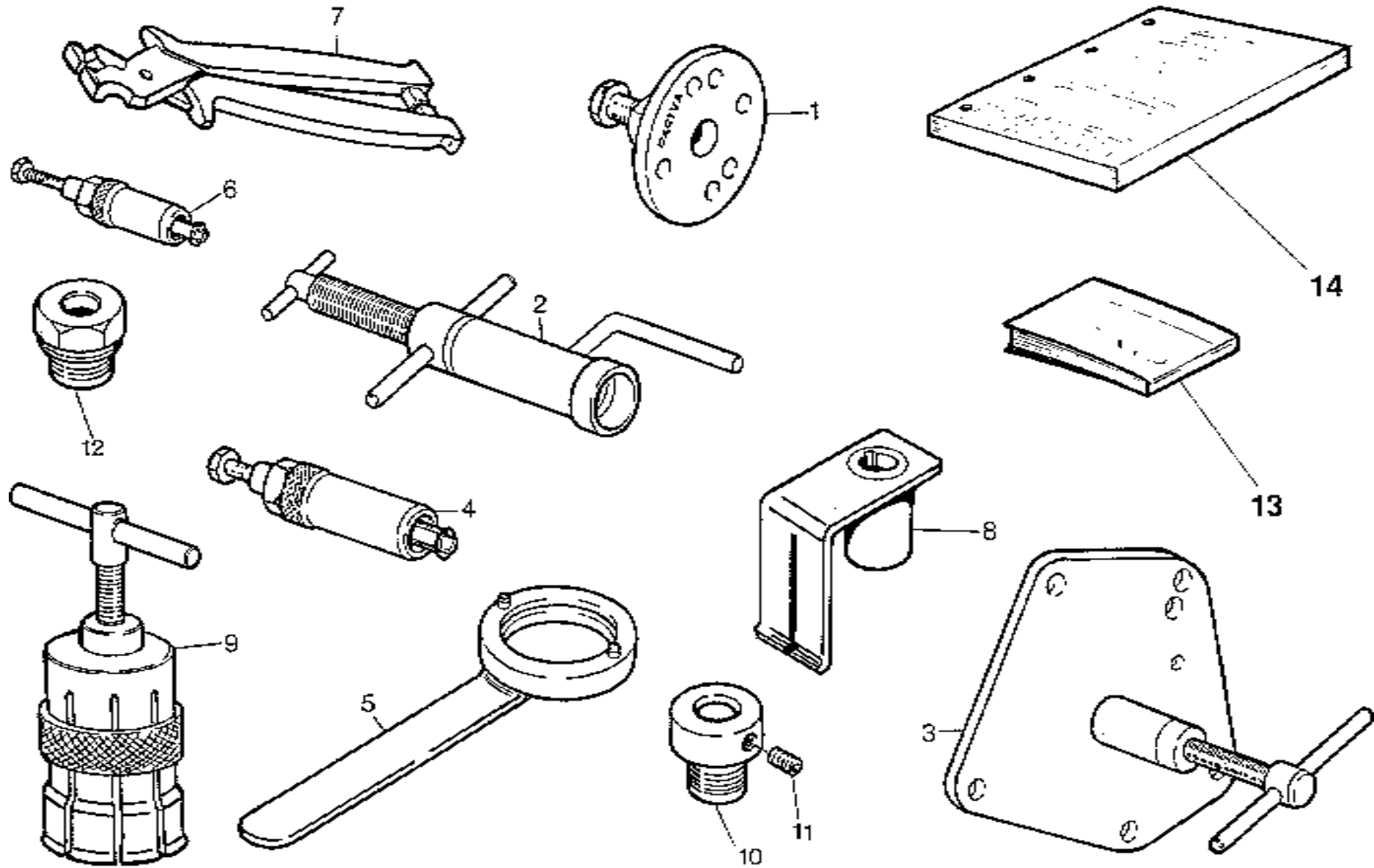

Note Notes Notas	Pos. No. N. Index Pos.	N° Codice Code No. Nr. Code Code Nr N. Cod.	Q.tà Q.ty Q.te M.ge C.ad	DENOMINAZIONE	NAME	DESIGNATION	BESHREIBUNG	DENOMINACION	Validità Validity Validité Gültig Valides
	1	8000 51614	1	Estrattore volante	Flywheel extractor	Extracteur pour volant	Auszieher für Schwungrad	Extractor volante	
	2	8000 33047	1	Attrezzo mont. alb. motore nel carter dx.	Installing tool crankshft right	Outil mont. vilebrequin R. Gehäuse	Werkzeug zur Mont. Kurbelwelle im demicarter D.	Herram. mont. eje motore	
	3	8000 33048	1	Attrezzo sep. semicarter e smont. albero motore	Crankcase splitting tool and cranksheft disassembly	Outil pour demontage carters et vilebrequin	Werkzeug für Trennung Gehäusehälfte und Demontage Motorwelle	Herramienta semi-carter	
	4	8000 43823	1	Estrattore cuscinetto a rullini alb. primario e per anello di tenuta pompa acqua	Needle bearing main shaft and seal ring water pump	Extracteur pour roulement à aiguilles, arbre pri. arbre prier pour bague d'étéchété pompe à eau	Auszieher für Nadelkäfig Abtroebswelle un Wasserpump Manchette	Extractor coijnete de rodillos eje primario y para segmento de retención bomba agua	
	5	8000 46614	1	Chiave smont. per volante	Flywheel removing wrench	Cléf démontage volant	Demontierschlüssel für Schwungrad	Llave desmont. para volante	
	6	8000 33054	1	Estrattore cuscinetto a rullini albero pompa olio	Needle bearing oil pump shft extractor	Extrac. pour roulement arbre pompe à huile	Auszieher für Nadelkäfig Oelpumpenwelle	Extrac. cijnete de rodillos eje bomba aceite	
	7	8000 49767	1	Pinza montaggio fascette	Clamp installing plier	Pince pour montage collier	Schellenzange	Pinza montaje abrazaderas	
	8	8000 48803	1	Atrezzo controllo fase accens.	Ignition control tool	Outil pour surveillance allumage	Werkzeug zur Kontrolle der Zündung	Herramienta control fase encendido	
	9	000Y A2271	1	Estrattore per cuscinetto albero motore	Crankshaft bearing extractor	Extracteur pour roulement vilebrequin	Auszieher für Antriebswellelager	Extractor coijnete cigüeñal	
	10	8000 70582	1	Attrezzo P.M.S.	Tool	Outil	Werkzeug	Herramienta	
	11	8000 51521	1	Vite	Screw	Vis	Schraube	Tornillo	
	12	8000 70569	1	Supporto comparatore	Support	Support	Halterung	Soporte	
	13	8000 86189	1	Libretto uso e manutenzione	Owner's manual	Emploi d'entretien	Betriebsanleitung	Manual y mantenimiento	
	14	8000 85827	1	Manuale d'officina	Workshhop manual	Manuel de service	Werkstatthandbuch	Manual de oficina	

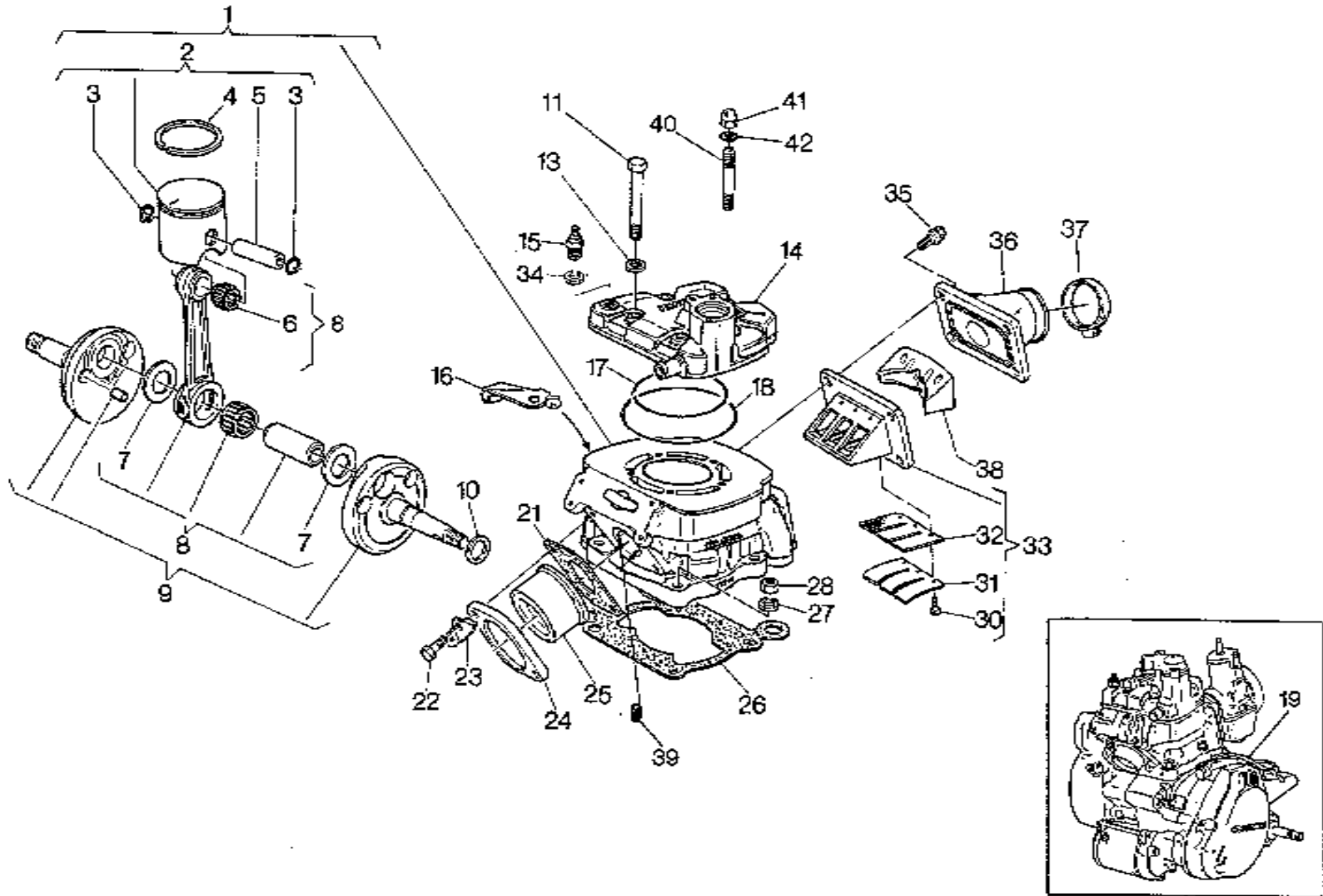

Note Notes Notas	Pos. No. N. Index	N° Codice Code No. Nr. Code Code Nr N. Cod.	Q.tà Q.ty Q.te M.ge C.ad	DENOMINAZIONE	NAME	DESIGNATION	BESHREIBUNG	DENOMINACION	Validità Validity Validité Gültig Valides
	1	8000 A0400	1	Ass. cilindro completo	Cylinder assy	Cylindre compl.	Zylinder kpl.	Cilindro compl.	
	2	8000 A0402	1	Ass. pistone A ø 55,960 ÷ 55,970	Piston assy D ø 55,95 ÷ 55,96	Piston compl. D ø 55,95 ÷ 55,96	Kolben kpl. D ø 55,95 ÷ 55,96	Pistón D ø 55,95 ÷ 55,96	
	2	8000 A0402	1	Ass. pistone B ø 55,970 ÷ 55,980	Piston assy D ø 55,95 ÷ 55,96	Piston compl. D ø 55,95 ÷ 55,96	Kolben kpl. D ø 55,95 ÷ 55,96	Pistón D ø 55,95 ÷ 55,96	
	2	8000 A0402	1	Ass. pistone C ø 55,980 ÷ 55,990	Piston assy D ø 55,95 ÷ 55,96	Piston compl. D ø 55,95 ÷ 55,96	Kolben kpl. D ø 55,95 ÷ 55,96	Pistón D ø 55,95 ÷ 55,96	
	3	8000 34358	2	Anellino	Ring	Bague	Ring	Anillo	
	4	8000 48381	2	Segmento	Piston ring	Segment	Kolbenring	Segmento	
	5	8000 37343	1	Spinotto	Pin	Gudgeon	Bolzen	Perno	
A	6	8000 21929	1	Cuscinetto per piede di biella	Needle bearing for small en rod	Roul. à aiguil. pour pied de biel.	Nadelkäfig für Pleuelauge	Col. para cuello de biella	
	7	8000 32231	2	Rondella	Washer	Rondelle	Scheibe	Arandela	
	8	8000 54884	1	Biella motore completa	Connecting rod compl.	Bielle compl.	Pleuelstange kpl.	Biela motor completa	
	9	8000 54882	1	Assieme albero motore	Crankshaft assy	Vilebrequin compl.	Kurbewelle kpl.	Juego eje motor	
	10	8A00 10350	1	Rosetta di ras. sp. 0,3 mm.	Washer	Rondelle	Scheibe	Arandela	
	10	8B00 10350	1	Rosetta di ras. sp. 0,4 mm.	Washer	Rondelle	Scheibe	Arandela	
	10	8C00 10350	1	Rosetta di ras. sp. 0,5 mm.	Washer	Rondelle	Scheibe	Arandela	
	10	8D00 10350	1	Rosetta di ras. sp. 0,6 mm.	Washer	Rondelle	Scheibe	Arandela	
	11	8000 62796	5	Vite	Screw	Vis	Schraube	Tornillo	
	13	8000 39335	5	Rosetta	Washer	Rondelle	Scheibe	Arandela	
	14	80A0 64818	1	Testa motore	Cylinder head	Culasse	Zylinderkopf.	Culata	
	14	80A0 54946	1	Testa motore (CH-A)	Cylinder head (CH-A)	Culasse (CH-A)	Zylinderkopf. (CH-A)	Culata (CH-A)	
	15	8000 67625	1	Termistore per testa	Thermistor	Thermistor	Thermistor	Thermistor	
	16	8000 67501	1	Piastrina	Plate	Plaquette	Plättchen	Placa	
	17	8000 38203	1	Guarnizione OR int. per testa	OR Gasket	Garniture "O"	O Ring Dichtung	Junta OR	
	18	8000 47707	1	Guarnizione OR est. per testa	OR Gasket	Garniture "O"	O Ring Dichtung	Junata OR	
	19	8000 85933	1	Assieme motore	Engine assy	Moteur complet	Motor kpl.	Motor compl.	
	19	8000 89855	1	Assieme motore (CH-A)	Engine assy (CH-A)	Moteur complet (CH-A)	Motor kpl. (CH-A)	Motor compl. (CH-A)	
	21	8000 30856	1	Guarnizione per flangia	Gasket	Garniture	Dichtung	Junta	
	21	8000 38228	1	Guarnizione per flangia (CH-A)	Gasket (CH-A)	Garniture (CH-A)	Dichtung (CH-A)	Junta (CH-A)	
	22	60N1 01082	2	Vite fiss. raccordo	Screw	Vis	Schraube	Tornillo	
	23	8000 57165	2	Piastrina	Plate	Plaquette	Plättchen	Placa	

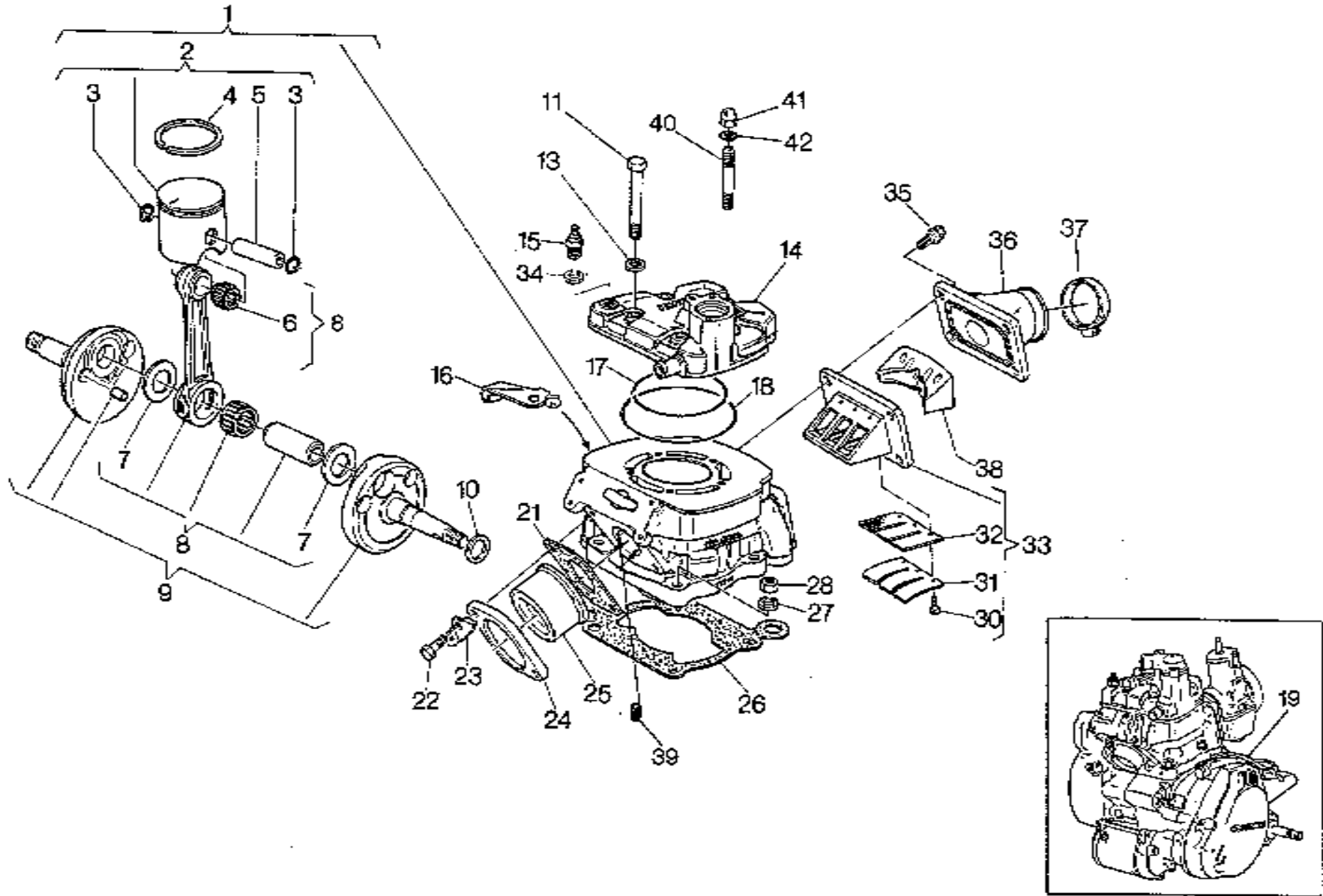

Note Notes Notas	Pos. No. N. Index Pos.	N° Codice Code No. Nr. Code Code Nr. N. Cod.	Q.ità Q.ity Q.ite M.ge C.ad	DENOMINAZIONE	NAME	DESIGNATION	BESHREIBUNG	DENOMINACION	Validità Validity Validité Gültig Valides
	24	8000 46592	1	Flangia	Flange	Bride	Flansch	Brida	
	25	8A00 46627	1	Raccordo	Union	Raccord	Anschluss	Empalme	
	25	8000 46627	1	Raccordo (CH-A)	Union (CH-A)	Raccord (CH-A)	Anschluss (CH-A)	Empalme (CH-A)	
	26	8C00 49557	1	Guarnizione sp. 0,5	Gasket	Garniture	Dichtung	Junta	
	26	8D00 49557	1	Guarnizione sp. 0,6	Gasket	Garniture	Dichtung	Junta	
	26	8E00 49557	1	Guarnizione sp. 0,7	Gasket	Garniture	Dichtung	Junta	
	27	8000 11276	4	Rosetta	Washer	Rondelle	Scheibe	Arandela	
	28	8000 17810	4	Dado fiss. cilindro	Nut	Ecrou	Mutter	Tuerca	
	30	8000 61102	6	Vite	Screw	Vis	Schraube	Tornillo	
	31	8000 69171	2	Piastrina	Plate	Plaquette	Plättchen	Placa	
	32	8000 67576	2	Lamella	Plate	Lamelle	Plättchen	Laminilla	
	33	8000 69172	1	Valvola aspirazione compl.	Inlet valve	Soupape admission	Einlass Ventil	Válvula aspiración	
	34	62N0 15676	1	Rosetta	Washer	Rondelle	Scheibe	Arandela	
	35	8000 62728	4	Vite fiss. valvola	Screw	Vis	Schraube	Tornillo	
	36	8000 72633	1	Raccordo	Union	Raccord	Anschluss	Empalme	
	37	7415 0441B	1	Fascetta	Clamp	Collier	Schelle	Banda	
	38	8000 65302	1	Inserto	Inlet	Piece	Einlass	Inserto	
	39	8000 70374	2	Vite BOOSTER (CH-A)	Screw (CH-A)	Vis (CH-A)	Schraube (CH-A)	Tornillo (CH-A)	
	40	8000 49556	5	Prigioniero (CH-A)	Stud bolt (CH-A)	Prisonnier (CH-A)	Stiftschraube (CH-A)	Prisionero (CH-A)	
	41	61N1 15095	5	Dado (CH-A)	Nut (CH-A)	Ecrou (CH-A)	Mutter (CH-A)	Tuerca (CH-A)	
	42	8000 39335	5	Rosetta (CH-A)	Washer (CH-A)	Rondelle (CH-A)	Scheibe (CH-A)	Arandela (CH-A)	
A				Accoppiamento piede biella	Connec.road small end coupl.	Couplage de pied de bielle	Verbindung despluelstangenk.	Acoplamiento pie de biela	

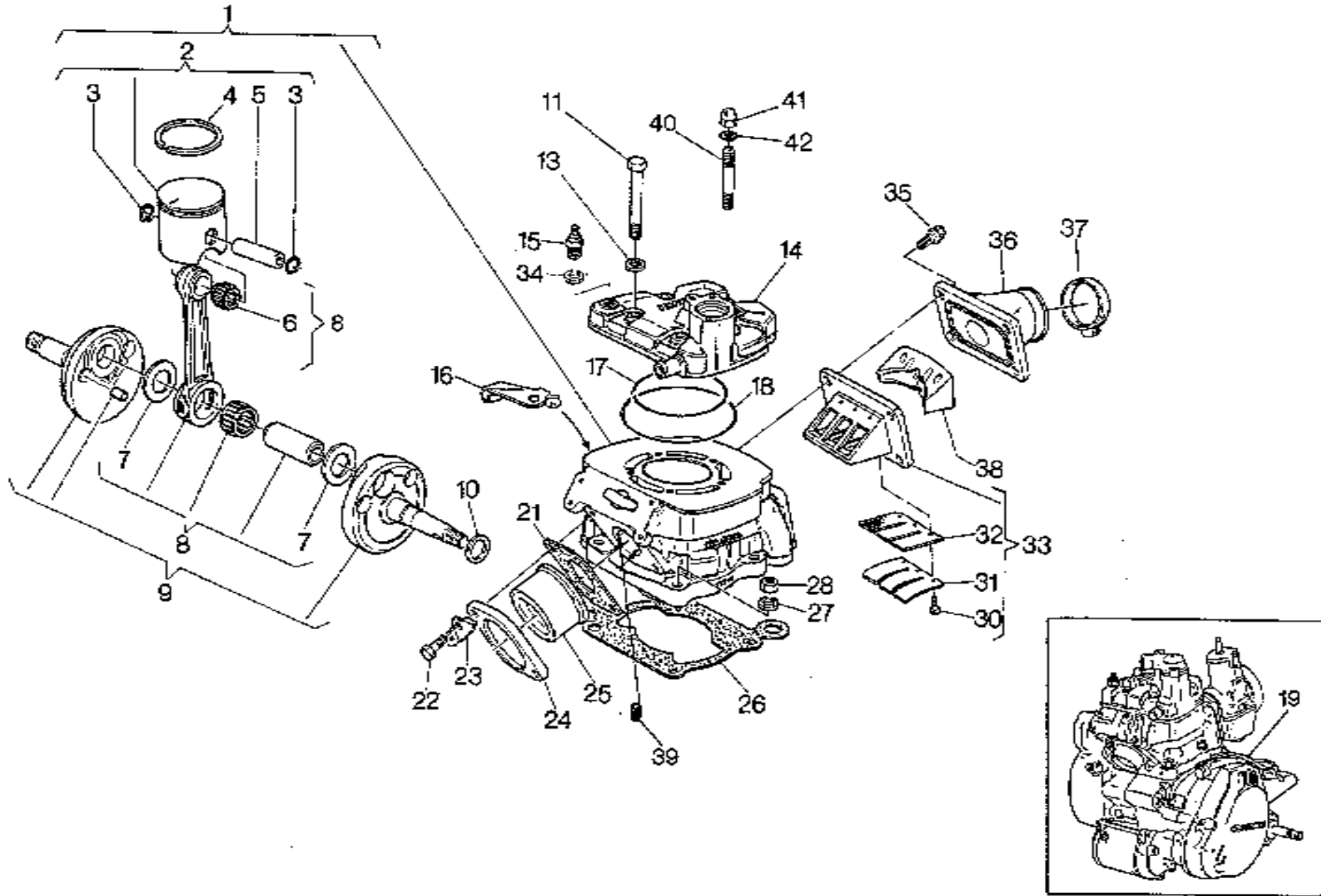

La sottoriportata tabella elenca i possibili accoppiamenti che consentono di ottenere il corretto gioco radiale di 0,002*0,010 mm

The table hereunder shows the possible coupling which allow to obtain a radial clearance of 0.002*0.010 mm

Le tableau ci-dessous indique tous les couplages possibles permettant d'obtenir le jeu radial exact de 0,002*0,010 mm

Die folgende Tabelle gibt die möglichen Verbindungen an für das genaue Radialspiel von 0,002*0,010 mm

La tabla que se da a continuación lista los acoplamientos posibles que permiten obtener el juego radial correcto de 0,002*0,010 mm

C: colore di selezione biella

C: rod selection colour

C: couleur de sélection bielle

C: Wahlfarbe der Pleuelstange

C: color de selección biela

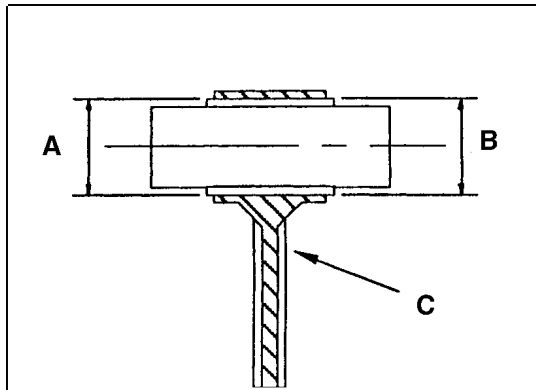

Colore di selezione foro «A» piede di biella (mm) Hole selection colour «A» connecting rod small end (mm) Couleur de sélection trou «A» pied de bielle (mm) Wahlfarbe der Bohrung «A» Pleuelstangenkopf (mm) Color de selección «A» pie de biela (mm)	Selezione gabbia a rullini «B» Cage selection «B» Sélection cage à rouleaux «B» Wahlradelkäfig «B» Selección jaula de agujas «B»
Giallo - Yellow - Jaune - Gelb - Amarillo 19,994 " 19,996	- 3 " - 5
Verde - Green - Vert - Grün - Verde 19,996 " 19,998	- 3 " - 5
Bianco - White - Blanc - Weiss - Blanco 19,998 " 20,000	- 1 " - 3 - 2 " - 4
Nero - Black - Noir - Schwarz - Negro 20,000 " 20,002	0 " - 2 - 1 " - 3
Rosso - Red - Rouge - Rot - Rojo 20,002 " 20,004	0 " - 2

Qualora, in sede di revisione del motore, si dovesse riscontrare un gioco radiale superiore al limite ammesso di 0,015 mm e non fosse più visibile il contrassegno del colore sullo stelo della biella, rilevare il diametro «A» del piede di biella e, in base a questo, montare la gabbietta appropriata.

When overhauling, should a radial clearance greater than the consented limit of 0.015 mm be noticed and the colour mark under the connecting rod small end is no more visible, collect the connecting rod small end «A» diameter and assemble the right cage according to it.

Si en révisonnant le moteur on trouve un jeu radial supérieur à la limite admise de 0,015 mm et le marque de la couleur n'est plus visible sur la tige de bielle, enregistrer le diamètre «A» du pied de bielle et assembler la cage exacte selon ce diamètre.

Falls bei Motorprüfung das Radialspiel über das zugelassene Mass von 0,015 mm sein sollte und das Farbkennzeichen an der Pleuelstange nicht mehr sichtbar ist, wird der «A»-Durchmesser des Pleuelstangenkopfes gemessen und aufgrund dessen der geeignete Käfig montiert..

En el caso que, cuando inspeccione el motor, encuentre un juego radial superior al límite admitido de 0,015 mm y no resultara más visible la señalización del color en el vástago de la biela, registre el diámetro «A» del piede biela y, sobre la base de este dato, monte la jaula adecuada.

NOTA: Nel richiedere la gabbia a rullini, specificare la selezione.

NOTE: When requesting the cage, specify the selection.

NOTA: En demandant la cage à rouleaux, spécifier la sélection.

BEMERKUNG: Bei Anfrage den genauen Wahlradelkäfig angeben.

NOTA: cuando pida la jaula de agujas, especifique la selección.

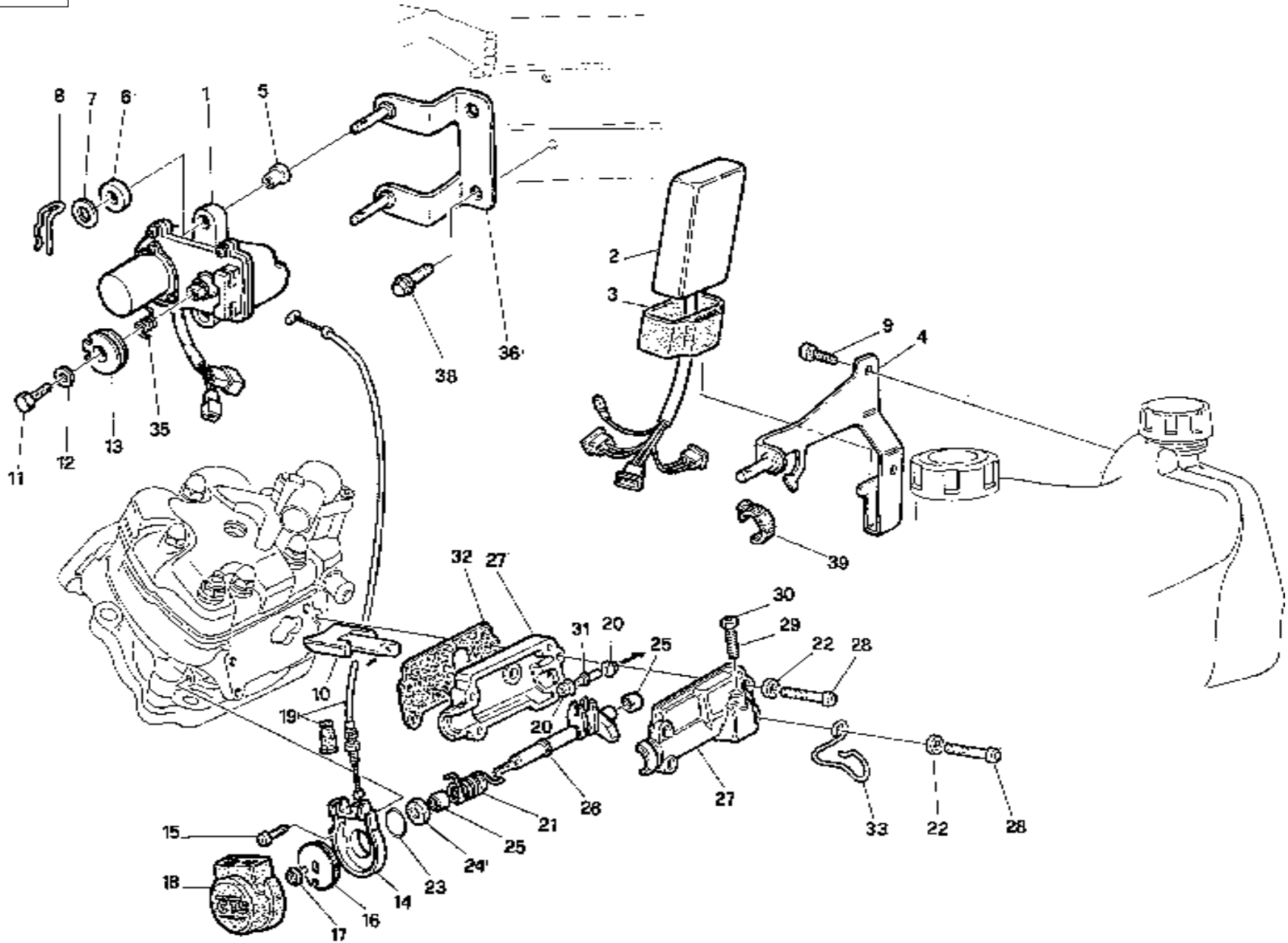

Note Notes Notas	Pos. No. N. Index Pos.	N° Codice Code No. Nr. Code Code Nr	Q.tà Q.ty Q.te M.ge C.ad	DENOMINAZIONE	NAME	DESIGNATION	BESHREIBUNG	DENOMINACION	Validità Validity Validité Gültig Valides
	1	8000 59034	1	Attuatore	Actuator	Actionneur	Trieb	Actuador	
	2	8000 86750	1	Controllo apertura valvola	Valve opening control	Contrôle d'ouvert. clapet	Kontrolle ventil Oeffnung	Control apertura valvula	
	3	8000 86751	1	Supporto elastico	Support	Support	Halterung	Soporte elástico	
	4	8000 86787	1	Supporto	Support	Support	Halterung	Soporte	
	5	8000 59287	2	Antivibrante	Silent block	Antivibration	Schwingungsdämpfer	Anti vibrador	
	6	8000 62390	2	Rosetta in gomma	Rubber washer	Rondella en caoutchouc	Gummischeibe	Roseta de goma	
	7	8000 39260	2	Rosetta piana	Washer	Rondelle	Scheibe	Arandela	
	8	8000 62705	2	Molletta	Spring	Ressort	Feder	Resorte	
	9	8000 62725	2	Vite	Screw	Vis	Schraube	Tornillo	
	10	8A00 67781	1	Valvola di scarico	Exhaust valve	Soupape d'échappement	Auslass Ventil	Válvula de escape	
	10	8A00 65250	1	Valvola di scarico (CH-A)	Exhaust valve (CH-A)	Soupape d'échappement (CH-A)	Auslass Ventil (CH-A)	Válvula de escape (CH-A)	
	11	60N1 01050	1	Vite	Screw	Vis	Schraube	Tornillo	
	12	60N1 15766	1	Rosetta elastica	Spring washer	Rondelle élastique	Federscheibe	Arandela elástica	
	13	8000 66204	1	Carrucola	Pulley	Poulie	Führungsrolle	Polea	
	14	8000 54894	1	Basetta	Button strip	Base poussoirs	Druckknopftafel	Placa	
	15	60N1 07330	1	Vite	Screw	Vis	Schraube	Tornillo	
	16	8000 54896	1	Carrucola	Pulley	Poulie	Führungsrolle	Polea	
	17	8000 42278	1	Dado	Nut	Ecrou	Mutter	Tuerca	
	18	8000 54893	1	Coperchio	Cover	Couvercle	Deckel	Tapa	
	19	8C00 58865	2	Trasmissione comando valvola	Throttle wire	Fil comm. gaz	Gaszugkabel	Trasmisión acc. acelerador	
	20	8000 58048	2	Rotella	Wheel	Galet	Rädchen	Ruedecilla	
	21	8000 54696	1	Molla	Spring	Ressort	Feder	Resorte	
	22	62N1 15503	4	Rosetta	Washer	Rondelle	Scheibe	Arandela	
	23	8000 36380	1	Anello di tenuta	Seal ring	Bague d'étanchéité	Dichtungsring	Anillo de retención	
	24	8000 64296	1	Anello di tenuta	Seal ring	Bague d'étanchéité	Dichtungsring	Anillo de retención	
	25	8000 31748	2	Cuscinetto a rullini	Needle bearing	Roulement à aiguilles	Nadelkäfig	Cojinete	
	26	8000 60430	1	Perno	Pin	Pivot	Bolzen	Perno	
	27	8000 58861	1	Ass. supp. e coperchio	Support and cover assy	Support et couvercle compl.	Kpl. Halter und Deckel	Soporte y tapa compl.	
	28	60N1 02489	4	Vite	Screw	Vis	Schraube	Tornillo	
	29	8000 49917	1	Vite	Screw	Vis	Schraube	Tornillo	
	30	61N1 15151	1	Dado	Nut	Ecrou	Mutter	Tuerca	
	31	8000 58046	1	Perno	Pin	Pivot	Bolzen	Perno	

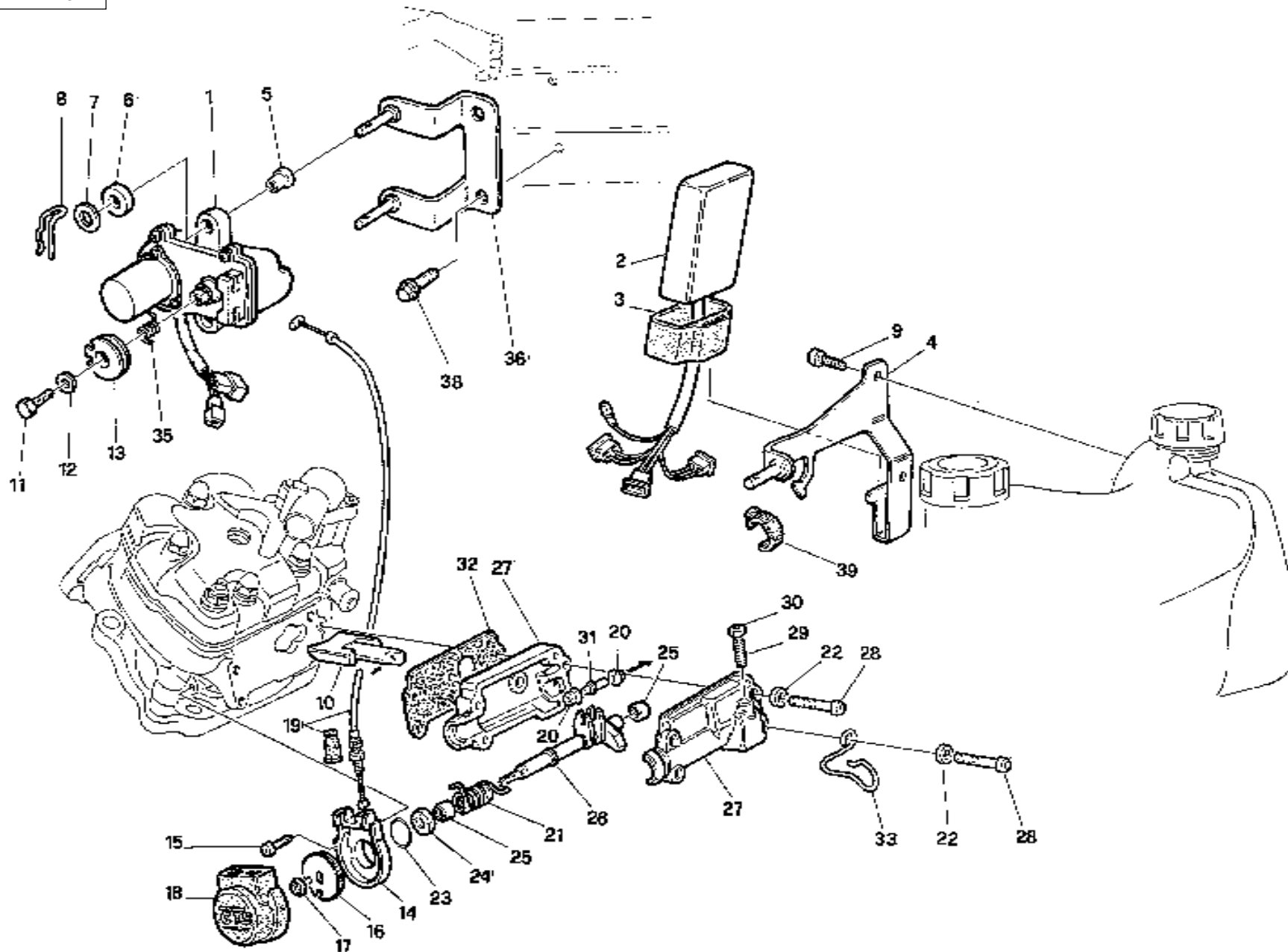

Note Notes Notes Mark Notas	Pos. No. N. Index Pos.	N° Codice Code No. Nr. Code Code Nr N. Cod.	Q.tà Q.ty Q.ite M.ge C.ad	DENOMINAZIONE	NAME	DESIGNATION	BESHREIBUNG	DENOMINACION	Validità Validity Validité Gültig Valides
	32	8000 47716	1	Guarnizione	Gasket	Garnitue	Dichtung	Junta	
	33	8000 89817	1	Passacavo	Fairlead	Passecâble	Kabelführung	Prensacable	
	35	8000 76984	1	Molla attuatore	Sring	Ressort	Feder	Resorte	
	36	8000 86514	1	Supporto	Support	Support	Halterung	Soporte	
	38	8000 62727	2	Vite	Screw	Vis	Schraube	Tornillo	
	39	8000 74287	1	Fascetta	Band	Collier	Schelle	Banda	

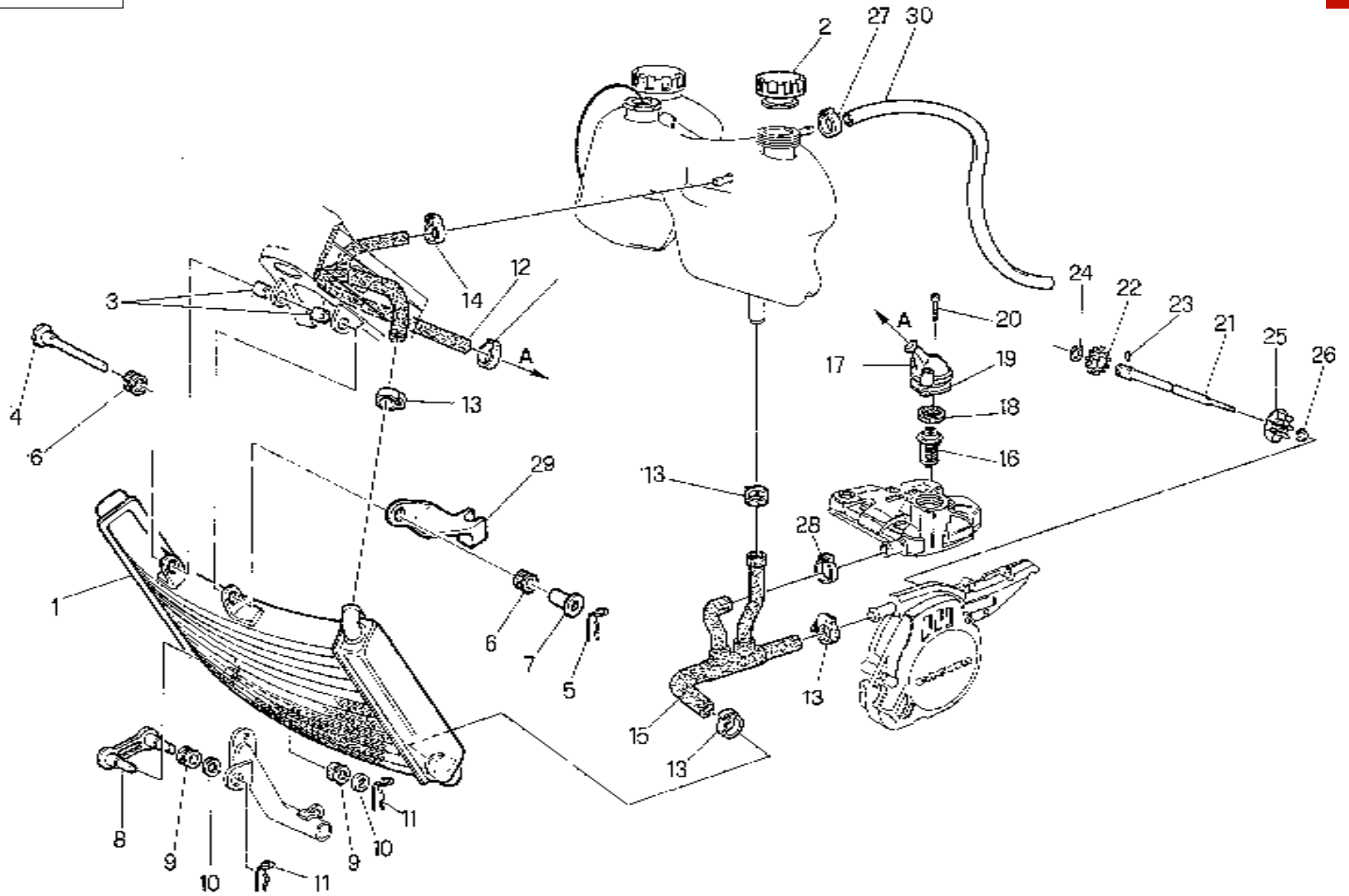

Note Notes Notas	Pos. No. N. Index Pos.	N° Codice Code No. Nr. Code Code Nr N. Cod.	Q.tà Q.ty Q.te M.ge C.ad	DENOMINAZIONE	NAME	DESIGNATION	BESHREIBUNG	DENOMINACION	Validità Validity Validité Gültig Valides
	1	8000 85829	1	Radiatore	Radiator	Radiateur	Kühler	Radiador	
	2	8931 0041A	1	Tappo	Plug	Bouchon	Verschluss	Tapón	
	3	8000 62703	2	Antivibrante	Silent block	Antivibration	Schwingungsdämpfer	Anti vibrador	
	4	8A00 62704	1	Spina	Pin	Goupille	Stift	Clavija	
	5	8000 62705	1	Graffetta	Clip	Agrafe	Klemmstueck	Clip	
	6	8000 62651	2	Antivibrante	Silent block	Antivibration	Schwingungsdämpfer	Anti vibrador	
	7	8000 62652	1	Distanziale	Spacer	Entretoise	Distanzstück	Separador	
	8	8000 85713	1	Supporto inf.	Support	Support	Halterung	Soporte	
	9	8000 62651	2	Antivibrante	Silent block	Antivibration	Schwingungsdämpfer	Anti vibrador	
	10	62N1 15549	2	Rosetta	Washer	Rondelle	Scheibe	Arandela	
	11	8000 62705	2	Graffetta	Clip	Agrafe	Klemmstueck	Clip	
	12	8000 85715	1	Manicotto	Sleeve	Manchon	Muffe	Manguito	
	13	8000 35751	5	Fascetta	Clamp	Collier	Schelle	Banda	
	14	8A00 67610	1	Fascetta	Clamp	Collier	Schelle	Banda	
	15	8000 85714	1	Manicotto	Sleeve	Manchon	Muffe	Manguito	
	16	8A00 47686	1	Termostato	Thermo switch	Thermostate	Thermostat	Termostato	
	17	8000 62717	1	Coperchio	Cover	Couvercle	Deckel	Tapa	
	18	8000 47701	1	Guarnizione	Gasket	Garnitue	Dichtung	Junta	
	19	8000 57536	1	Guarnizione	Gasket	Garnitue	Dichtung	Junta	
	20	60N1 07335	2	Vite	Screw	Vis	Schraube	Tornillo	
	21	8000 59980	1	Albero	Shaft	Arbre	Welle	Eje	
	22	8000 42285	1	Ingranaggio	Gear	Engrenage	Zahnrad	Engranaje	
	23	8000 42259	1	Rullino	Roller	Aiguille	Rolle	Rodillo	
	24	66N0 21202	1	Anello elastico	Split ring	Anneau ressort	Sprengring	Anillo elástico	
	25	8000 60415	1	Girante	Rotor	Couronne	Laufrad	Rotor	
	26	8000 42278	1	Dado	Nut	Ecrou	Mutter	Tuerca	
	27	8C00 67963	1	Fascetta	Clamp	Collier	Schelle	Banda	
	28	8000 46881	1	Fascetta	Clamp	Collier	Schelle	Banda	
	29	8000 87073	1	Piastrina	Plate	Plaquette	Plättchen	Placa	
	30	8E00 66179	1	Sfiato	Breather pipe	Évent	Entlüfter	Purga	

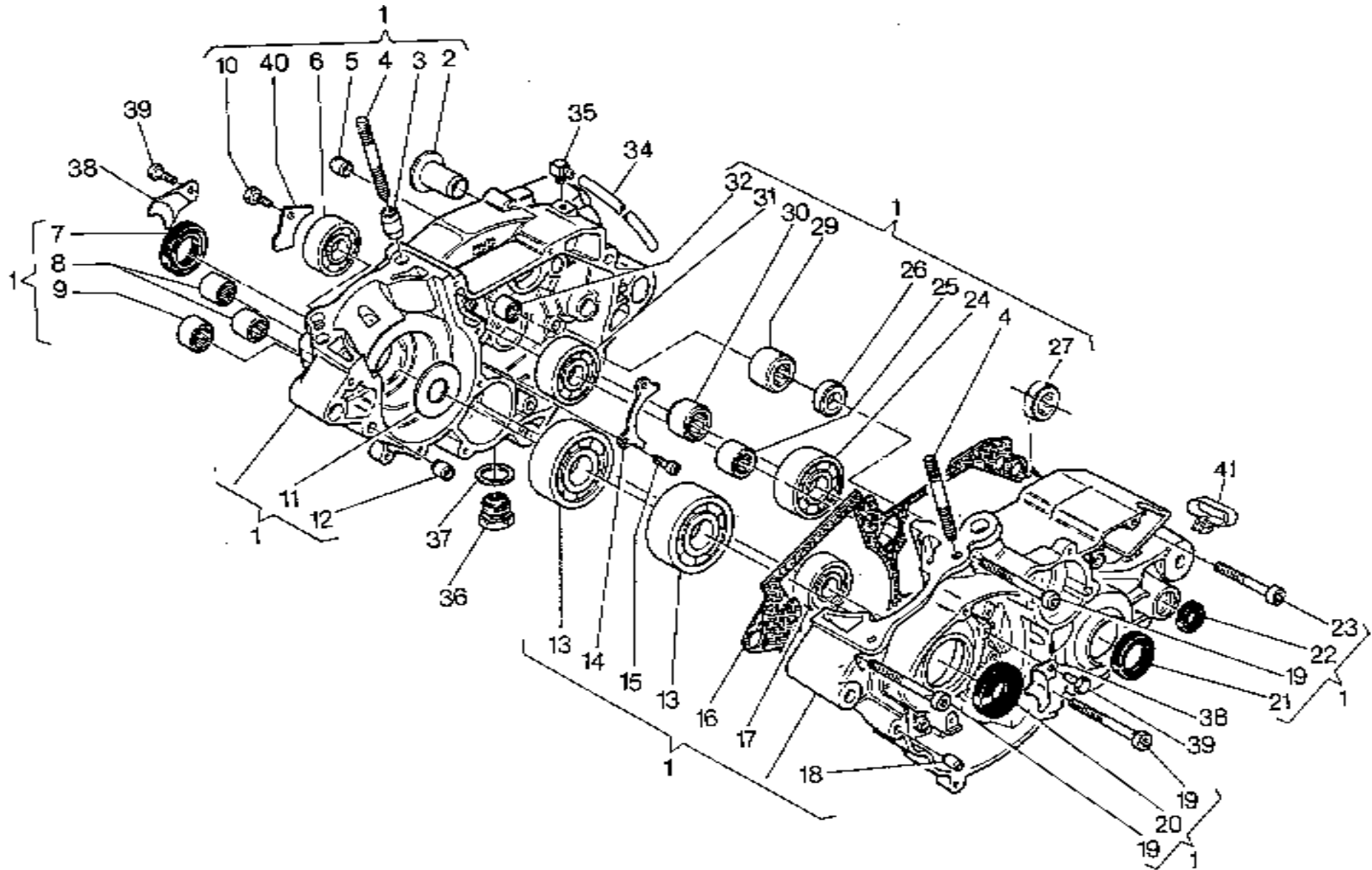

Note Notes Notas	Pos. No. N. Index	N° Codice Code No. Nr. Code Code Nr C. Cod.	Q.tà Q.ty Q.te M.ge C.ad	DENOMINAZIONE	NAME	DESIGNATION	BESHREIBUNG	DENOMINACION	Validità Validity Validité Gültig Valides
	1	8000 86756	1	Carter motore compl.	Crankcase assy	Carter compl.	Kurberlgehaue kpl.	Carter motor completi	
	2	8000 33642	2	Bussola per asse forcellone	Bushing	Douille	Büchse	Manguito	
	3	8000 47708	2	Bussola rif. cilindro	Bushing	Douille	Büchse	Manguito	
	4	8000 30860	4	Prigioniero	Stud bolt	Prisonnier	Stiftschraube	Prisionero	
	5	8000 51971	2	Bussola	Bushing	Douille	Büchse	Manguito	
	6	8000 53248	1	Cuscinetto contralbero	Bearing	Roulement	Lager	Cojinete	
	7	8000 30728	1	Anello di tenuta	Seal ring	Bague d'étanchéité	Dichtungsring	Anillo de retención	
	8	8000 47678	2	Boccola	Bush	Douille	Büchse	Casquillo	
	9	8000 49016	1	Cuscinetto rinvio contralbero	Needle bearing	Roulement à aiguilles	Nadelkäfig	Cojinete	
	10	60N1 01078	1	Vite di fissaggio	Screw	Vis	Schraube	Tornillo	
	11	8000 42164	1	Rosetta	Washer	Rondelle	Scheibe	Arandela	
	12	8000 07719	2	Bussola di riferimento	Bushing	Douille	Büchse	Manguito	
	13	8000 42155	2	Cuscinetto albero motore	Bearing	Roulement	Lager	Cojinete	
	14	8000 48861	1	Piastrina	Plate	Plaquette	Plättchen	Placa	
	15	60N1 02483	2	Vite	Screw	Vis	Schraube	Tornillo	
	16	8000 48862	1	Guarnizione	Gasket	Garnitue	Dichtung	Junta	
	17	8000 53248	1	Cuscinetto contralbero	Bearing	Roulement	Lager	Cojinete	
	18	8000 51549	2	Spina	Pin	Goupille	Stift	Clavija	
	19	60N1 02516	3	Vite	Screw	Vis	Schraube	Tornillo	
	20	8000 32389	1	Anello di tenuta	Seal ring	Bague d'étanchéité	Dichtungsring	Anillo de retención	
	21	8000 36357	1	Anello di tenuta	Seal ring	Bague d'étanchéité	Dichtungsring	Anillo de retención	
	22	8000 22946	1	Anello di tenuta	Seal ring	Bague d'étanchéité	Dichtungsring	Anillo de retención	
	23	60N1 02515	8	Vite	Screw	Vis	Schraube	Tornillo	
	24	8000 24947	1	Cuscinetto albero secondario	Bearing	Roulement	Lager	Cojinete	
	25	8000 37198	1	Cuscinetto a rullini albero	Needle bearing	Roulement à aiguilles	Nadelkäfig	Cojinete	
	26	8000 53339	1	Anello di tenuta per pompa	Seal ring	Bague d'étanchéité	Dichtungsring	Segmento de compresión	
	27	8000 62200	1	Cuscinetto	Bearing	Roulement	Lager	Cojinete	
	29	8000 47678	1	Cuscinetto albero pompa acqua	Bearing	Roulement	Lager	Cojinete	
	30	8000 36440	1	Cuscinetto albero secondario	Bearing	Roulement	Lager	Cojinete	
	31	8000 43382	1	Cuscinetto albero primario	Bearing	Roulement	Lager	Cojinete	
	32	8000 33718	1	Boccola	Bush	Douille	Büchse	Casquillo	
	34	8000 41750	1	Tube	Pipe	Tuyau	Rohr	Tube	

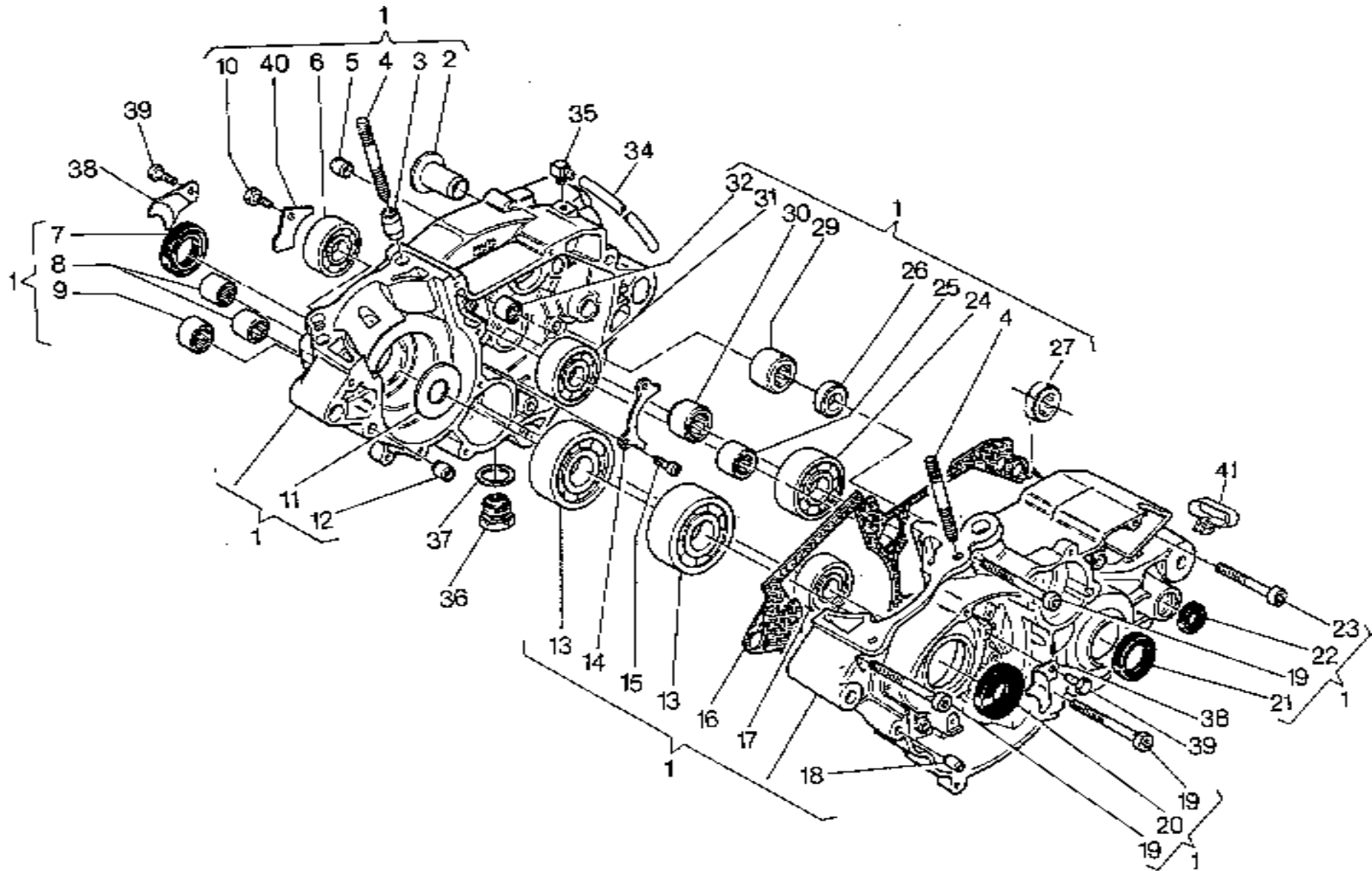

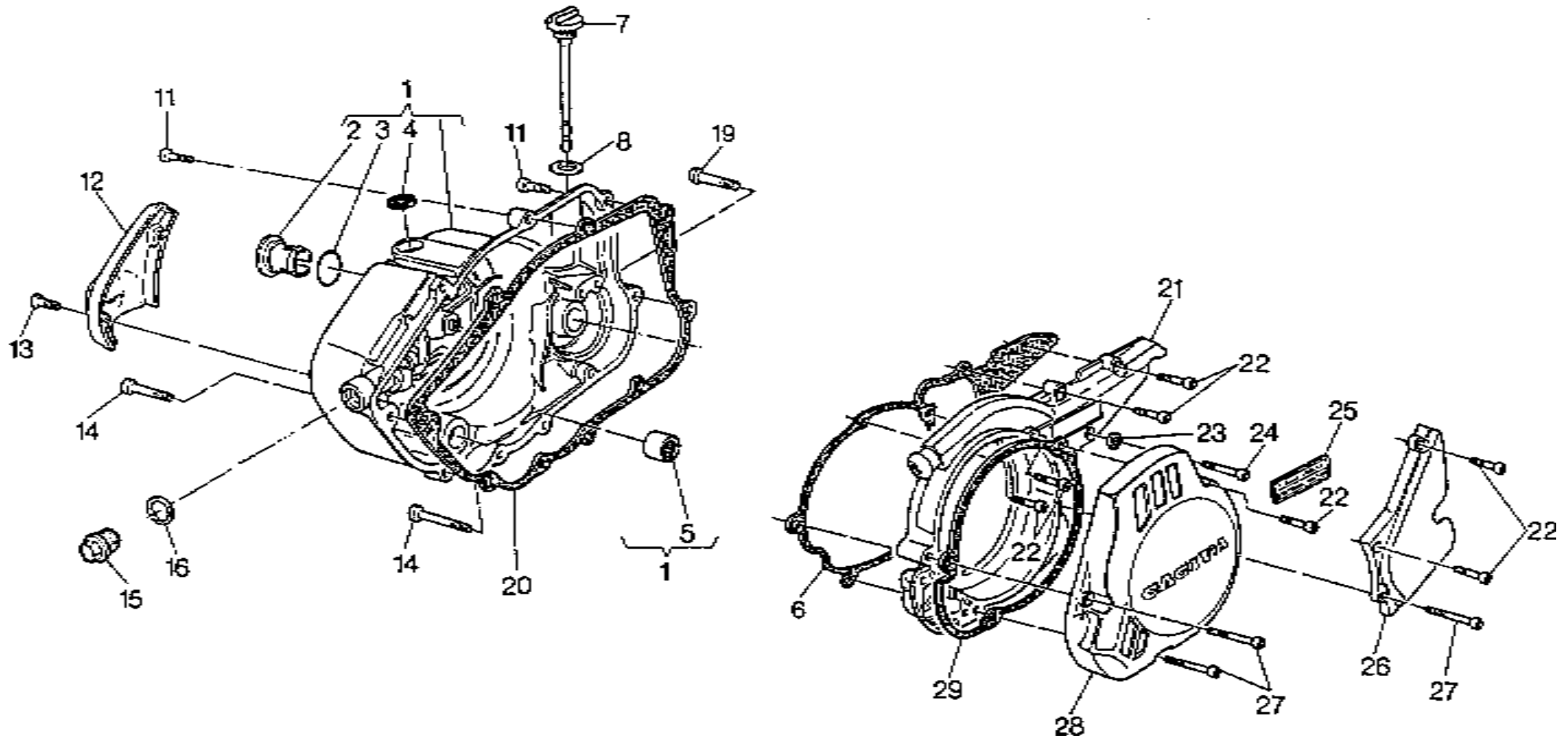

Note Notes Notas	Pos. No. N. Index Pos.	N° Codice Code No. Nr. Code Code Nr N. Cod.	Q.tà Q.ty Q.te M.ge C.ad	DENOMINAZIONE	NAME	DESIGNATION	BESHREIBUNG	DENOMINACION	Validità Validity Validité Gültig Valides
	1	8C00 66843	1	Assieme coperchio destro	Right cover assembly	Ensemble couvercle droit	Aggregat rechter Dekel	Juego tapa derecha	
	2	8000 56006	1	Tappo	Plug	Bouchon	Verschluss	Tapón	
	3	8000 34323	1	Anello di tenuta	Seal ring	Bague d'étanchéité	Dichtungsring	Anillo de retención	
	4	8000 48856	1	Anello di tenuta	Seal ring	Bague d'étanchéité	Dichtungsring	Anillo de retención	
	5	8000 49016	1	Cuscinetto a rullini	Needle bearing	Roulement à aiguilles	Nadelkäfig	Cojinete	
	6	8000 48865	1	Guarnizione	Gasket	Garnitue	Dichtung	Junta	
	7	8000 57185	1	Tappo	Plug	Bouchon	Verschluss	Tapón	
	8	8000 27960	1	Rosetta	Washer	Rondelle	Scheibe	Arandela	
	11	60N1 02510	6	Vite	Screw	Vis	Schraube	Tornillo	
	12	80A0 66845	1	Coperchio pompa olio	Oil pump cover	Couvercle pompe a huile	Ölpumpendeckel	Tapa bomba aceite	
	13	8000 24962	2	Vite	Screw	Vis	Schraube	Tornillo	
	14	60N1 02512	2	Vite	Screw	Vis	Schraube	Tornillo	
	15	80A0 31817	1	Tappo	Plug	Bouchon	Verschluss	Tapón	
	16	62N0 15599	1	Rosetta	Washer	Rondelle	Scheibe	Arandela	
	19	60N1 02512	1	Vite	Screw	Vis	Schraube	Tornillo	
	20	8000 48864	1	Guarnizione	Gasket	Garnitue	Dichtung	Junta	
	21	8000 47375	1	Flangia	Flange	Bride	Flansch	Brida	
	22	60N1 07335	7	Vite	Screw	Vis	Schraube	Tornillo	
	23	8000 15960	1	Guarnizione	Gasket	Garnitue	Dichtung	Junta	
	24	60N1 02511	1	Vite	Screw	Vis	Schraube	Tornillo	
	25	8000 38078	1	Targhetta autoadesiva	Trim	Décalcomanie	Abziehbild	Autoadhesivos	
E	26	80A0 47377	1	Coperchio pignone	Cover	Couvercle	Deckel	Tapa	
	26	80A0 88204	1	Coperchio pignone	Cover	Couvercle	Deckel	Tapa	
	27	60N1 02515	3	Vite	Screw	Vis	Schraube	Tornillo	
	28	80B0 66847	1	Coperchio vano accensione	Cover	Couvercle	Deckel	Tapa	
	29	8000 52292	1	Guarnizione	Gasket	Garnitue	Dichtung	Junta	
E				Ad esaurimento	To fell out	A' finir	Erschöpfung	A agotamiento	

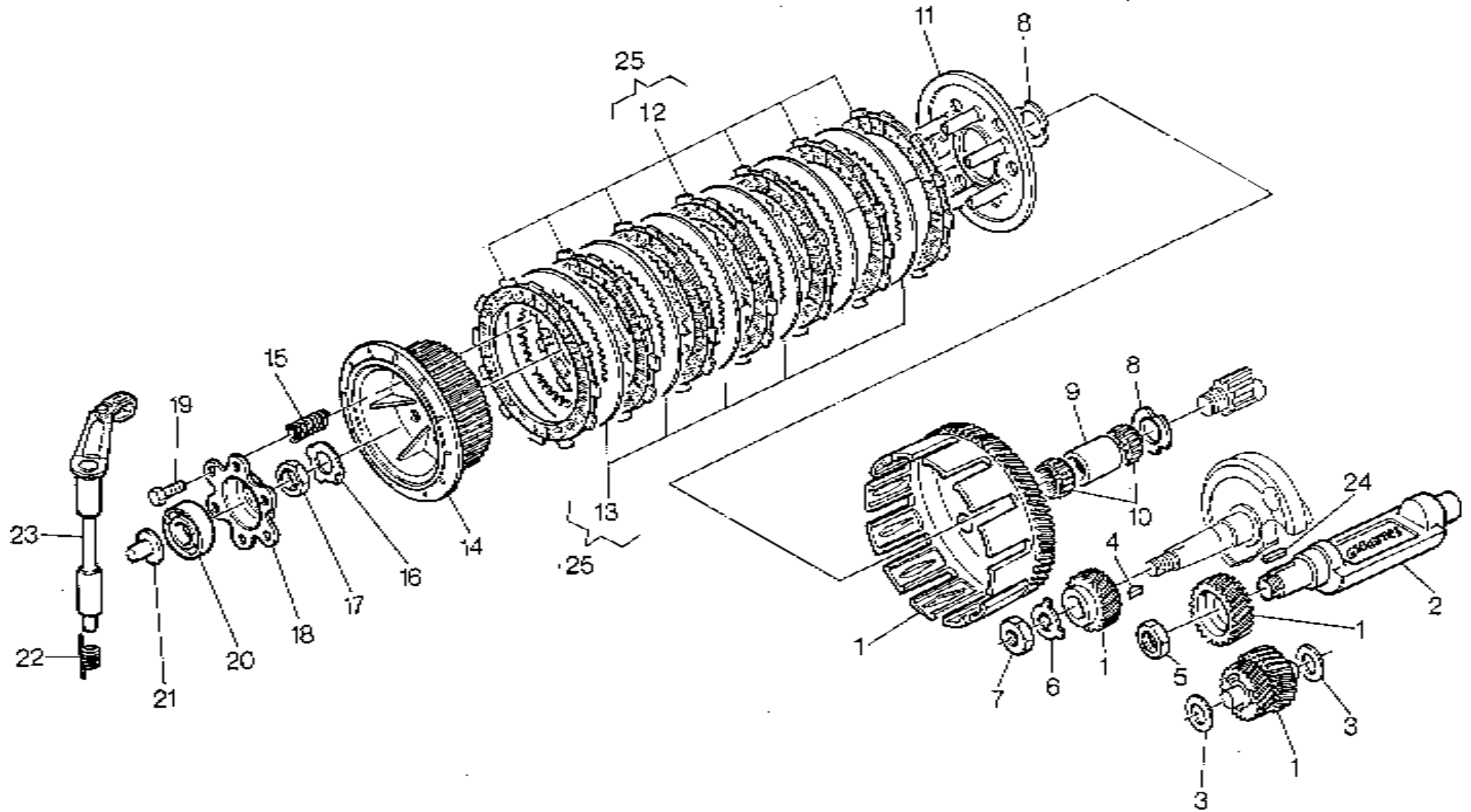

Note Notes Notas	Pos. No. N. Index Pos.	N° Codice Code No. Nr. Code Code Nr N. Cod.	Q.tà Q.ty Q.te M.ge C.ad	DENOMINAZIONE	NAME	DESIGNATION	BESHREIBUNG	DENOMINACION	Validità Validity Validité Gültig Valides
	1	8000 64833	1	Coppia ingranaggi primaria	Set of matched primary	Engrenages trans. prim.	Stirnradpaar	Copla engranaje trans. primar.	
	2	8000 47719	1	Contralbero di equilibrio	Layshaft	Arbre de bal.	Worgelegewelle	Contra eje	
	3	8000 11868	2	Rosetta di rasam. sp. 0,3 mm.	Washer	Rondelle	Scheibe	Arandela	
	3	8A00 11868	2	Rosetta di rasam. sp. 0,5 mm.	Washer	Rondelle	Scheibe	Arandela	
	3	8B00 11868	2	Rosetta di rasam. sp. 0,6 mm.	Washer	Rondelle	Scheibe	Arandela	
	3	8C00 11868	2	Rosetta di rasam. sp. 0,7 mm.	Washer	Rondelle	Scheibe	Arandela	
	3	8D00 11868	2	Rosetta di rasam. sp. 0,8 mm.	Washer	Rondelle	Scheibe	Arandela	
	3	8E00 11868	2	Rosetta di rasam. sp. 0,9 mm.	Washer	Rondelle	Scheibe	Arandela	
	3	8F00 11868	2	Rosetta di rasam. sp. 1 mm.	Washer	Rondelle	Scheibe	Arandela	
	3	8G00 11868	2	Rosetta di rasam. sp. 1,1 mm.	Washer	Rondelle	Scheibe	Arandela	
	3	8H00 11868	2	Rosetta di rasam. sp. 1,2 mm.	Washer	Rondelle	Scheibe	Arandela	
	4	65N0 21007	1	Linguetta	Woodruff key	Clé woodruff	Federkeil	Lengüeta	
	5	80A0 47665	1	Dado	Nut	Ecrou	Mutter	Tuerca	
	6	8000 31739	1	Rosetta	Washer	Rondelle	Scheibe	Arandela	
	7	80A0 47665	1	Dado	Nut	Ecrou	Mutter	Tuerca	
	8	8000 46428	2	Rosetta	Washer	Rondelle	Scheibe	Arandela	
	9	8000 42288	1	Distanziale	Spacer	Entretoise	Distanzstück	Separador	
	10	8000 25044	2	Gabbia a rullini	Needle cage	Cage à aiguilles	Nadelkaefig	Jaula de agujas del cojinete	
	11	8000 31813	1	Disco premifrizione	Disc	Disque	Scheibe	Disco	
	12	8000 75935	7	Disco conduttore	Driving disc	Disque conducteur	Belagscheibe	Disco conductor	
	13	8000 33192	6	Disco condotto	Driven disc	Disque conduit	Sthlscheibe	Disco conducido	
	14	8000 48874	1	Mozzo portadischi	Clutch hub	Moyeu porte disque	Scheibenhalternabe	Porta discos	
	15	8000 44346	6	Molla frizione	Clutch spring	Ressort embrayage	Kupplungsfeder	Resorte embrague	
	16	8000 38727	1	Rosetta	Washer	Rondelle	Scheibe	Arandela	
	17	8000 38726	1	Dado	Nut	Ecrou	Mutter	Tuerca	
	18	8000 48875	1	Disco ritegno molle	Plate	Disque	Platte	Disco	
	19	8000 30820	6	Vite	Screw	Vis	Schraube	Tornillo	
	20	8000 01025	1	Cuscinetto	Bearing	Roulement	Lager	Cojinete	
	21	8000 48852	1	Piattello	Plate	Plateau	Teller	Placa	
	22	8000 48855	1	Molla richiamo	Spring	Ressort	Feder	Resorte	
	23	8000 48853	1	Ass. leva comando frizione	Clutch control lever, assy	Levier comm. embray. compl.	Kupplungshebel, Kpl.	Palanca embrague comp.	
	24	8000 38707	1	Linguetta	Woodruff key	Clé woodruff	Federkeil	Lengüeta	

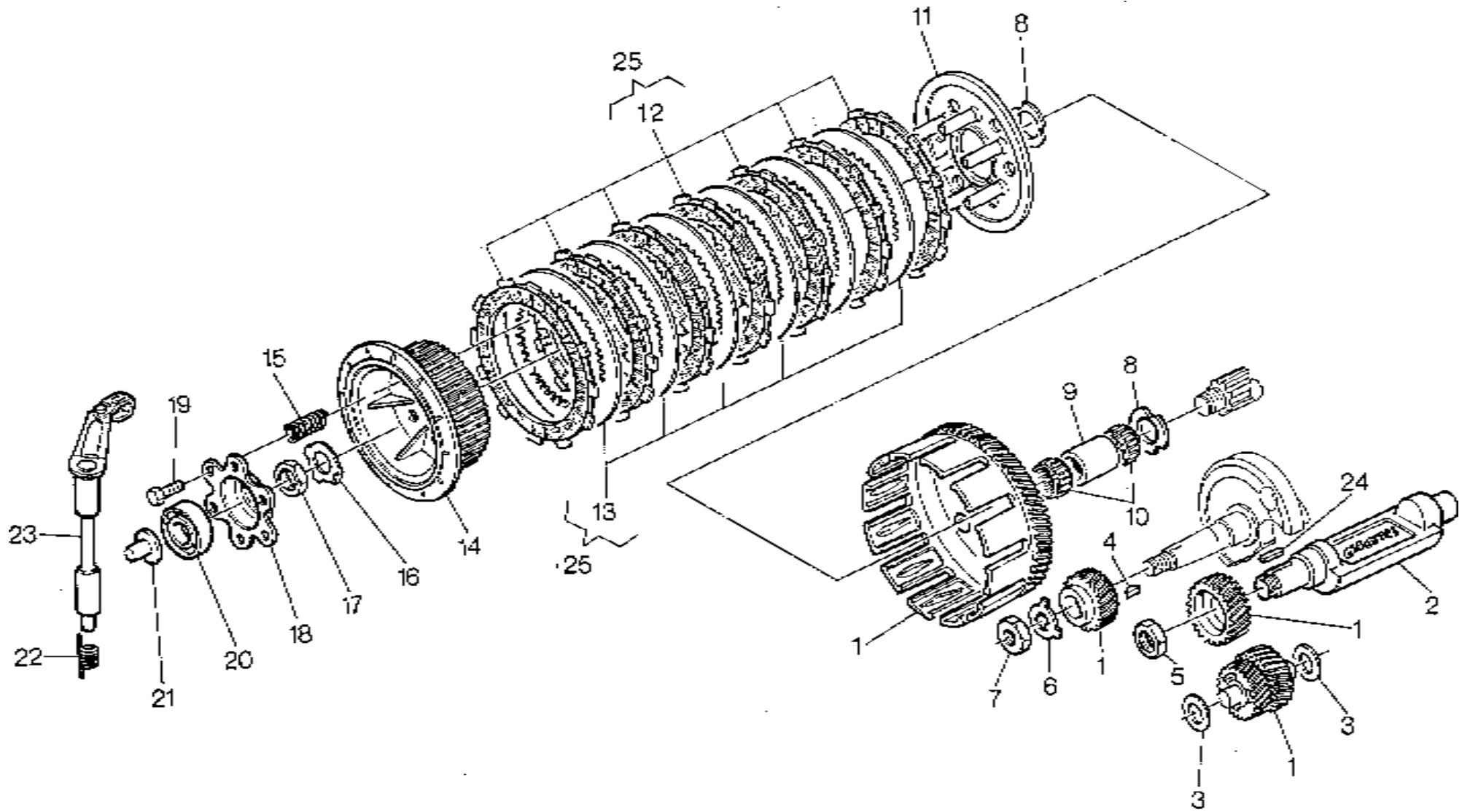

Note Notes Notes Marke Notas	Pos. No. N. Index Pos.	N° Codice Code No. Nr. Code Code Nr N. Cod.	Q.tà Q.ty Q.te M.ge C.ad	DENOMINAZIONE	NAME	DESIGNATION	BESHREIBUNG	DENOMINACION	Validità Validity Validité Gültig Valides
	25	8000 82864	1	Ass. gruppo frizione	Clutch group assy	Groupe embrayage compl.	Kupplungsgruppe Kpl	Grupo embrague compl.	

PLANET 125

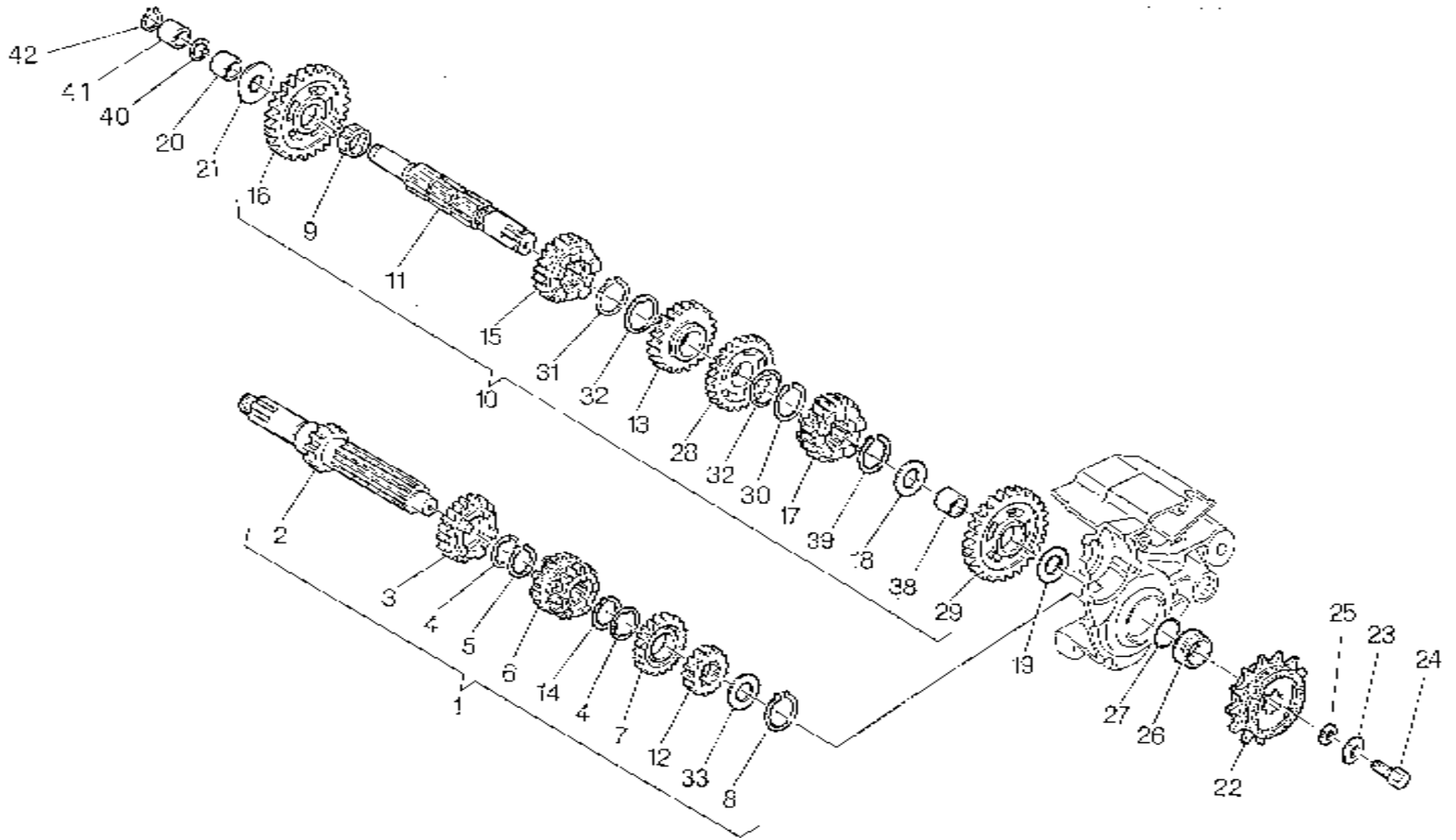

Note Notes Notas	Pos. No. N. Index	N° Codice Code No. Nr. Code Code Nr C. Cod.	Q.tà Q.ty Q.te M.ge C.ad	DENOMINAZIONE	NAME	DESIGNATION	BESHREIBUNG	DENOMINACION	Validità Validity Validité Gültig Valides
	1	8000 69247	1	Ass. albero primario	Main shaft compl.	Arbre primaire compl.	Hauptwelle, Kpl.	primario comp.	
	2	8000 69248	1	Albero primario Z=11	Main shaft	Arbre primaire	Hauptwelle	Eje primario	
	3	8000 52447	1	Ingran. 6ª velocità A.P. Z=22	Main shaft 6th gear	Engrenage 6ème vitesse A.P.	Zahn. f. 6. Geschw. Antriebsw.	Engranaje 6º velocidad Eje P.	
	4	8000 25151	2	Rosetta di rasamento	Thrust washer	Rondelle de butée	Ausgleichscheibe	Arandela de tope	
	5	60N2 21208	1	Anello elastico	Ring	Bague	Sprengring	Anillo elástico	
	6	8000 46532		Ingranaggio 3ª vel. Z=17 e	Driven gear 3rd and 4th speed	Engrenage conduit 3ème et	Zahnrad 3. u. 4. Gang	Engr. 3º y 4º velocidad	
			1	4ª vel. Z=21 A.P.		4 éme			
	7	8000 53130	1	Ingranaggio 5ª vel. A.P. Z=23	Gear 5th speed	Engrenage 5ème	Zahnrad 5. Gang	Engranaje 5º velocidad	
	8	8000 53392	1	Anello elastico	Ring	Bague	Sprengring	Anillo elástico	
	9	8000 31773	1	Cuscinetti a rullini	Needle bearing	Roulement à rouleaux	Nadelkäfig	Cojinete de rodillos	
	10	8000 69252	1	Ass. albero secondario	Layshaft compl.	Arbre secondaire compl.	Vorgelegewelle, Kpl.	secondario comp.	
	11	8000 69273	1	Albero secondario	Layshaft	Arbre secondaire	Vorgelegewelle	secondario	
	12	8000 69249	1	Ingranaggio 2ª vel. A.P. Z=14	Main shaft 2rd gear	Engrenage 2ème vitesse A.P.	Zahn. f. 2. Geschw. Antriebsw.	Engranaje 2º velocidad Eje P.	
	13	8000 46534	1	Ingranaggio 4ª vel. A.S. Z=23	Secondary shaft 4th gear	Engrenage 4ème vitesse A.S.	Zahn.f.4. Geschw. Vorgelegew.	Engranaje 4º velocidad Eje S.	
	14	8000 34690	1	Anello elastico	Ring	Bague	Sprengring	Anillo elástico	
	15	8000 52448	1	Ingranaggio 6ª vel. Z=19 A.S	Secondary shaft 6th gear	Engrenage 6ème vitesse A.S.	Zahn. f. 6. Geschw. Vorgelegew.	Engranaje 6º velocidad Eje S.	
	16	8000 54695	1	Ingranaggio 1ª vel. Z=30 A.S.	Gear 1st speed	Engrenage 1ère	Zahnrad 1. Gang	Engranaje 1º velocidad	
	17	8000 69250	1	Ingranaggio 5ª vel. Z=22 A.S.	Gear 5th speed	Engrenage 5ème	Zahnrad 5. Gang	Engranaje 5º velocidad	
	18	8000 43199	1	Rosetta di rasamento	Thrust washer	Rondelle de butée	Ausgleichscheibe	Arandela de tope	
	19	8000 07989	1	Rosetta di rasam. sp.0,3 mm	Thrust washer	Rondelle de butée	Ausgleichscheibe	Arandela de tope	
	19	8B00 07989	1	Rosetta di rasam. sp.0,5 mm	Thrust washer	Rondelle de butée	Ausgleichscheibe	Arandela de tope	
	19	8E00 07989	1	Rosetta di rasam. sp.0,8 mm	Thrust washer	Rondelle de butée	Ausgleichscheibe	Arandela de tope	
	19	8G00 07989	1	Rosetta di rasam. sp.1,0 mm	Thrust washer	Rondelle de butée	Ausgleichscheibe	Arandela de tope	
	19	8I00 07989	1	Rosetta di rasam. sp.1,2 mm	Thrust washer	Rondelle de butée	Ausgleichscheibe	Arandela de tope	
	20	8000 54874	1	Anello	Ring	Bague	Ring	Anillo	
	21	8000 05272	1	Rosetta di rasam. sp.0,3 mm	Thrust washer	Rondelle de butée	Ausgleichscheibe	Arandela de tope	
	21	8C00 05272	1	Rosetta di rasam. sp.0,8 mm	Thrust washer	Rondelle de butée	Ausgleichscheibe	Arandela de tope	
	21	8E00 05272	1	Rosetta di rasam. sp.1,0 mm	Thrust washer	Rondelle de butée	Ausgleichscheibe	Arandela de tope	
	21	8G00 05272	1	Rosetta di rasam. sp.1,2 mm	Thrust washer	Rondelle de butée	Ausgleichscheibe	Arandela de tope	
	22	8000 49778	1	Pignone uscita cambio Z=14.	Pinion	Pignon	Ritzel	Piñón	
	23	8000 73650	1	Rosetta di sicurezza	Washer	Rondelle	Scheibe	Arandela	
	24	60N10 1140	2	Vite	Screw	Vis	Schraube	Tornillo	

PLANET 125

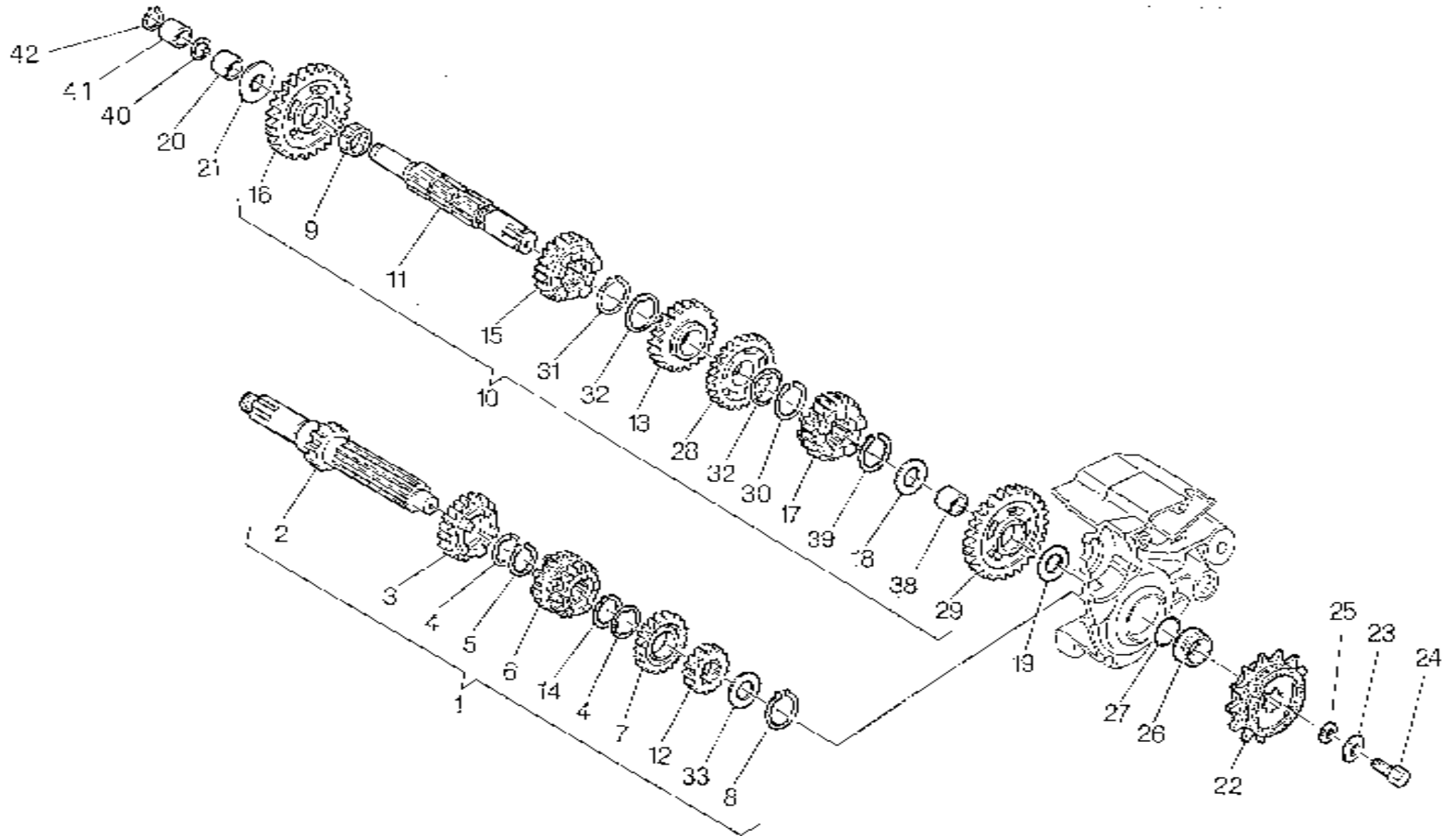

Note Notes Notas	Pos. No. N. Index Pos.	N° Codice Code No. Nr. Code Code Nr N. Cod.	Q.tà Q.ty Q.te M.ge C.ad	DENOMINAZIONE	NAME	DESIGNATION	BESHREIBUNG	DENOMINACION	Validità Validity Validité Gültig Valides
	25	8000 73649	2	Rosetta	Washer	Rondelle	Scheibe	Arandela	
	26	8A00 31744	1	Distanziale	Spacer	Entretoise	Distanzstück	Separador	
	27	8000 19789	1	Anello OR	O-Ring	Bague OR	O-Ring	Anillo OR	
	28	8000 46533	1	Ingranaggio 3ª vel. A.S. Z=23	Secondary shaft 3rd gear	Engrenage 3ème vitesse A.S.	Zahnf.3.Geschw. Vorgelegew.	Engranaje 3º velocidad Eje S.	
	29	8000 69251	1	Ingranaggio 2ª vel. A.S. Z=26	Secondary shaft 2rd gear	Engrenage 2ème vitesse A.S.	Zahnf.2.Geschw. Vorgelegew.	Engranaje 2º velocidad Eje S.	
	30	8000 31768	4	Anello elastico	Ring	Bague	Sprengring	Anillo elástico	
	31	8000 31768	4	Anello elastico	Ring	Bague	Sprengring	Anillo elástico	
	32	8000 43199	4	Rosetta di rasamento	Thrust washer	Rondelle de butée	Ausgleichscheibe	Arandela de tope	
	33	8000 38210	1	Rosetta di rasam. sp.0,3 mm	Thrust washer	Rondelle de butée	Ausgleichscheibe	Arandela de tope	
	33	8B00 38210	1	Rosetta di rasam. sp.0,5 mm	Thrust washer	Rondelle de butée	Ausgleichscheibe	Arandela de tope	
	33	8D00 38210	1	Rosetta di rasam. sp.0,8 mm	Thrust washer	Rondelle de butée	Ausgleichscheibe	Arandela de tope	
	33	8F00 38210	1	Rosetta di rasam. sp.1,0 mm	Thrust washer	Rondelle de butée	Ausgleichscheibe	Arandela de tope	
	33	8H00 38210	1	Rosetta di rasam. sp.1,2 mm	Thrust washer	Rondelle de butée	Ausgleichscheibe	Arandela de tope	
	38	8000 61261	1	Bussola	Bushing	Douille	Buchse	Manguito	
	39	8000 21209	1	Anello elastico	Ring	Bague	Sprengring	Anillo elástico	
	40	8D00 04553	1	Rosetta	Washer	Rondelle	Scheibe	Arandela	
	41	8000 56770	1	Distanziale	Spacer	Entretoise	Distanzstück	Separador	
	42	66N0 21204	1	Anello elastico	Ring	Bague	Sprengring	Anillo elástico	

PLANET 125

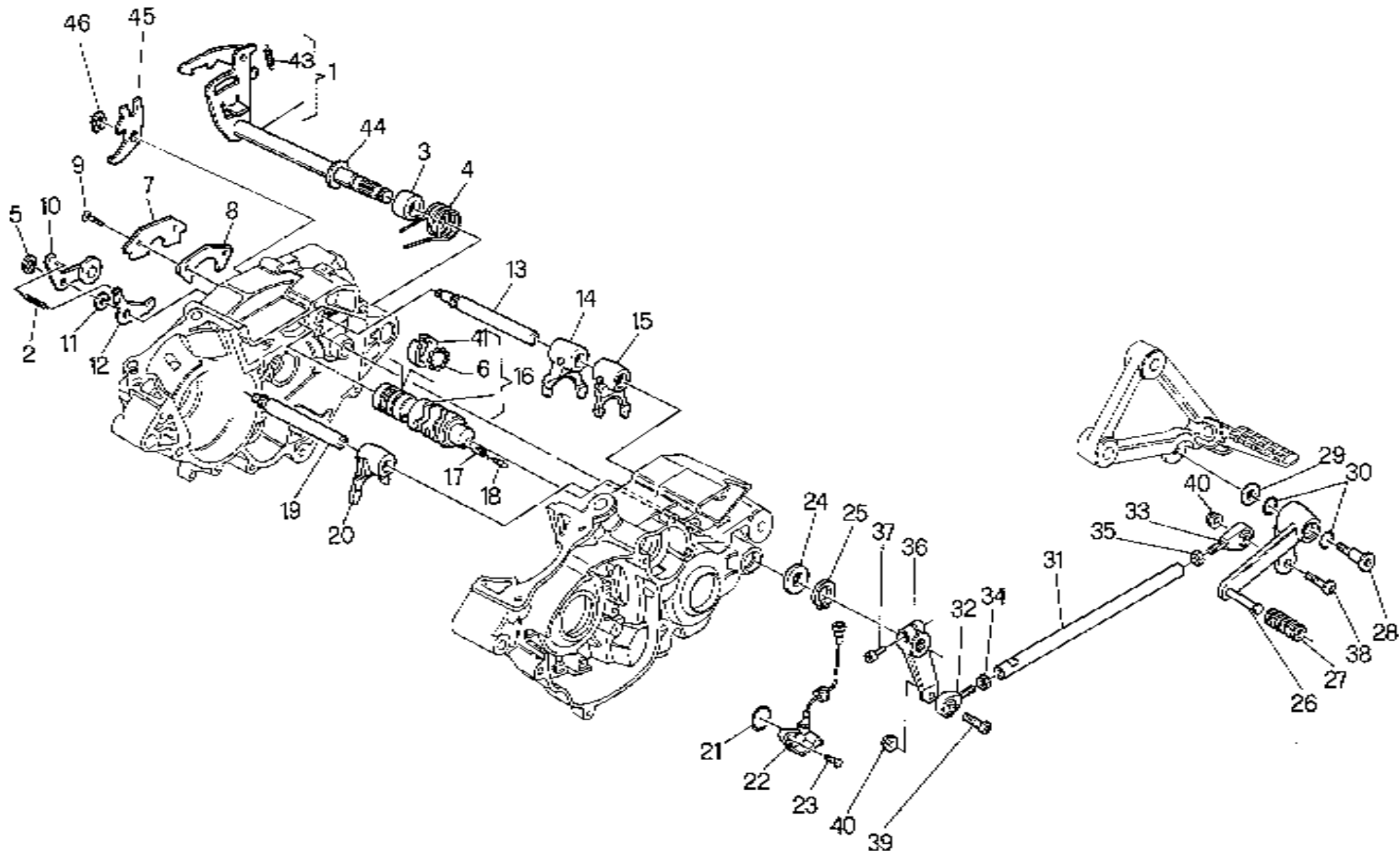

Note Notes Notas	Pos. No. N. Index	N° Codice Code No. Nr. Code Code Nr. N. Cod.	Q.tà Q.ty Q.te M.ge C.ad	DENOMINAZIONE	NAME	DESIGNATION	BESHREIBUNG	DENOMINACION	Validità Validity Validité Gültig Valides
	1	8000 62195	1	Assieme selettore	Selector assembly	Ensemble sélecteur	Aggregat Wählschalter	Juego selector	
	2	8000 27103	1	Molla	Spring	Ressort	Feder	Resorte	
	3	8000 24857	1	Bussola	Bushing	Douille	Büchse	Manguito	
	4	8000 62210	1	Molla	Spring	Ressort	Feder	Resorte	
	5	8000 21375	1	Anello elastico	Split ring	Anneau ressort	Sprengring	Anillo elástico	
	6	6BN0 21505	15	Sfera	Ball	Bille	Kugel	Esfera	
	7	8000 24840	1	Piastrina di ritegno	Plate	Plaquette	Plättchen	Placa	
	8	8A00 24841	1	Piastrina di rasam. sp. 0,3 mm.	Plate	Plaquette	Plättchen	Placa	
	8	8000 24841	1	Piastrina di rasam. sp. 0,2 mm.	Plate	Plaquette	Plättchen	Placa	
	9	60N1 03834	2	Vite	Screw	Vis	Schraube	Tornillo	
	10	8000 34035	1	Assieme salterello fissa marce	Gear fixing clik assembly	Cliquet compl.	Strumhaken kpl.	Salt. fijo marchas	
	11	8000 43859	1	Rosetta di rasam. sp. 0,2 mm.	Washer	Rondelle	Scheibe	Arandela	
	11	8A00 43859	1	Rosetta di rasam. sp. 0,3 mm.	Washer	Rondelle	Scheibe	Arandela	
	12	8000 44300	1	Salterello fissa folle	Pawl	Clique	Sturmhaken	Salt. fijo neutro	
	13	8000 24839	1	Perno forc. 1ª, 2ª, 3ª, 4ª, vel.	Pin 1st, 2nd, 3rd, 4th	Pivot 1ème, 2ème, 3ème, 4ème	Stift 1, 2, 3, 4	Perno horquilla 1°, 2°, 3°, 4°,	
	14	8000 26134	1	Forcella ing. 1ª e 4ª vel. A.S.	Fork gear shifter 1st, 4th	Fourch 1ère, 4ème	Schaltgabelachse 1,4	Horquilla engr. 1°, 4° vel.	
	15	8000 35119	1	Forcella ing. 2ª e 3ª vel. A.S.	Fork gear shifter 2st, 3th	Fourche 2ère, 3ème	Schaltgabelachse 2, 3	Horquilla engr. 2°, 3° vel.	
	16	8000 69253	1	Albero comando forcelle	Fork driving shaft	Arbre de commande fourche	Steuerwelle f. Gabel	Eje mando horquilla	
	17	8000 42677	1	Molla	Spring	Ressort	Feder	Resorte	
	18	8000 42676	1	Puntale	Push rod	Embout	Stösselschaft	Puntal	
	19	8000 44299	1	Perno forcella 5ª, 6ª e 7ª vel.	Pin 5th, 6th and 7th	Pivot 5ème, 6ème, 7ème	Stift 5., 6., 7.	Perno horquil, 5°, 6°, 7° vel.	
	20	8000 33721	1	Forcella ing. 5ª e 6ª vel. A.P.	Fork gear shifter 5th, 6th	Fourch 5ème, 6ème	Schaltgabelachse 5, 6	Horquilla engr. 5° y 6° vel.	
	21	8000 42700	1	Anello OR	O ring	Bague OR	O ring	Anillo OR	
	22	8A00 41682	1	Segnatore folle	Loose transponder	Signaleur	Leerlicht	Senalador	
	23	8000 25254	2	Vite	Screw	Vis	Schraube	Tornillo	
	24	8000 19604	1	Rosetta	Washer	Rondelle	Scheibe	Arandela	
	25	66N0 21203	1	Anello elastico	Split ring	Anneau ressort	Sprengring	Anillo elástico	
	26	8000 66174	1	Pedale cambio	Pedal	Pedale	Pedal	Pedale	
	27	8000 62636	1	Manicotto	Sleeve	Manchon	Muffe	Manguito	
	28	80A0 53548	1	Perno	Pin	Pivot	Bolzen	Perno	
	29	8000 59485	1	Rondella	Washer	Rondelle	Scheibe	Arandela	
	30	8000 01199	2	Anello di tenuta	Seal ring	Bague d'étanchéité	Dichtungsring	Anillo de retención	

PLANET 125

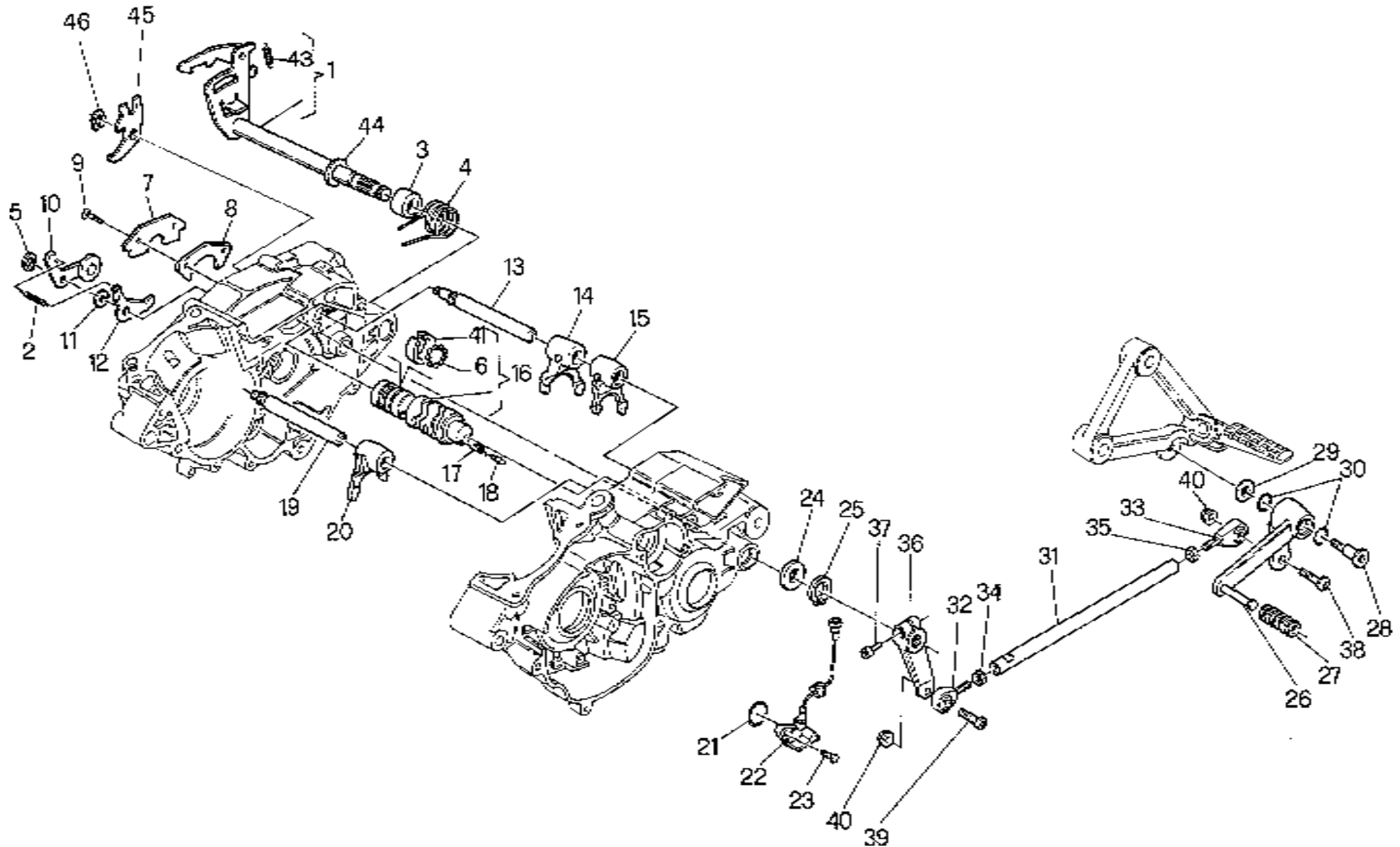

Note Notes Notas	Pos. No. N. Index Pos.	N° Codice Code No. Nr. Code Code Nr. N. Cod.	Q.tà Q.ty Q.te M.ge C.ad	DENOMINAZIONE	NAME	DESIGNATION	BESHREIBUNG	DENOMINACION	Validità Validity Validité Gültig Valides
	31	8B00 60686	1	Astina	Control rod	Coulisseau	Steuerstange	Varilla	
A	32	8000 76055	1	Snodo sferico sx	Ball joint	Joint a rotule	Kugelgelenk	Articulación esférica	
	32	7640 10003	1	Snodo sferico sx	Ball joint	Joint a rotule	Kugelgelenk	Articulación esférica	
	33	8A00 76055	1	Snodo sferico dx	Ball joint	Joint a rotule	Kugelgelenk	Articulación esférica	
A	33	7640 10002	1	Snodo sferico dx	Ball joint	Joint a rotule	Kugelgelenk	Articulación esférica	
	34	8000 56459	1	Dado	Nut	Ecrou	Mutter	Tuerca	
	35	61N1 15062	1	Dado	Nut	Ecrou	Mutter	Tuerca	
	36	8000 60684	1	Leva	Lever	Levier	Lasche	Palanca	
	37	7715 6672B	1	Vite	Screw	Vis	Schraube	Tornillo	
	38	8000 61070	1	Vite	Screw	Vis	Schraube	Tornillo	
	39	8000 61070	1	Vite	Screw	Vis	Schraube	Tornillo	
	40	8000 44240	2	Dado	Nut	Ecrou	Mutter	Tuerca	
	41	8000 61260	1	Anello elastico	Split ring	Anneau ressort	Sprengring	Anillo elástico	
	43	8000 27103	1	Molla	Spring	Ressort	Feder	Resorte	
	44	8A00 09408	1	Rosetta	Washer	Rondelle	Scheibe	Arandela	
	45	8000 24856	1	Piastrina	Plate	Plaquette	Plättchen	Placa	
	46	8000 21375	1	Anello elastico	Split ring	Anneau ressort	Sprengring	Anillo elástico	
A				In alternativa	In alternative	En alternative	Die Auswahl	En alternativa	

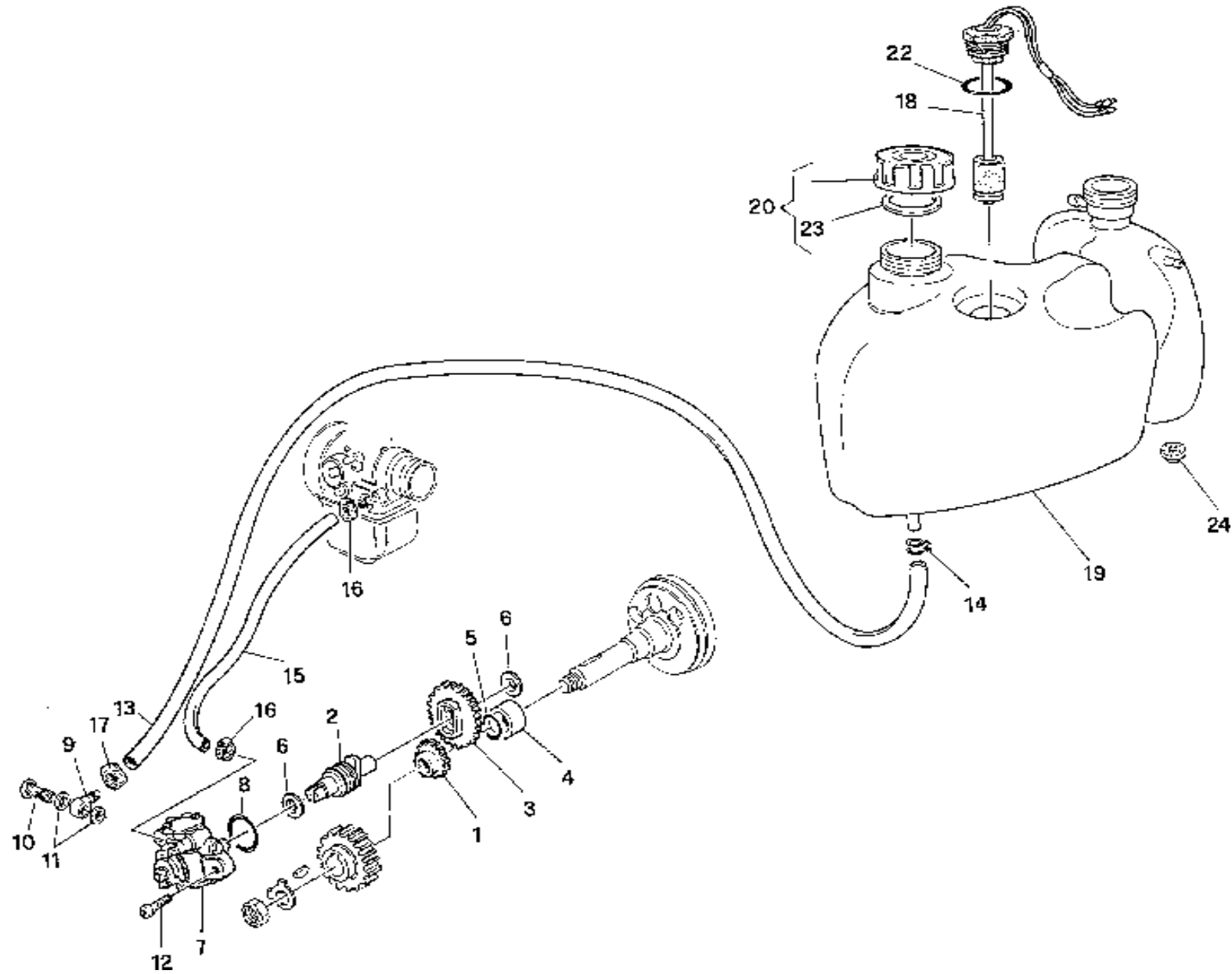

Note Notes Notas	Pos. No. N. Index Pos.	N° Codice Code No. Nr. Code Code Nr N. Cod.	Q.tà Q.ty Q.te M.ge C.ad	DENOMINAZIONE	NAME	DESIGNATION	BESHREIBUNG	DENOMINACION	Validità Validity Validité Gültig Valides
	1	8000 92027	1	Pignone pompa olio z= 21	Pinion	Pignon	Ritzel	Piñón	
	2	8000 51662	1	Albero di rinvio	Lay shaft	Arbre renvoi	Vorgelegewelle	Eje reenvío	
	3	8000 51660	1	Ingran. com. pompa z= 42	Pump gear	Engrenage pompe	Zahnrad f. Pumpe	Engranaje com. bomba	
	4	8000 47667	1	Distanziale	Spacer	Entretoise	Distanzstück	Separador	
	5	8000 26884	1	Anello OR per detto	O Ring	Bague OR	O Ring	Anillo OR	
	6	8000 33270	2	Rosetta di rasamento per ingr.	Washer	Rondelle	Scheibe	Arandela	
	7	8000 52129	1	Pompa olio	Oil pump	Pompe à huile	Ölpumpe	Anillo de retención	
	8	8000 71764	1	Anello di tenuta	Seal ring	Bague d'étanchéité	Dichtungsring	Anillo de retención	
	9	8000 19069	1	Raccordo	Union	Raccord	Anschluss	Empalme	
	10	8000 19070	1	Vite	Screw	Vis	Schraube	Tornillo	
	11	8000 19071	2	Rosetta	Washer	Rondelle	Scheibe	Arandela	
	12	8000 24962	2	Vite	Screw	Vis	Schraube	Tornillo	
	13	8000 68873	1	Condotto	Duct	Conduit	Rohr	Conducto	
	14	8000 64586	1	Fascetta	Clamp	Collier	Schelle	Banda	
	15	8000 33272	1	Condotto	Duct	Conduit	Rohr	Conducto	
	16	8000 33273	2	Fascetta	Clamp	Collier	Schelle	Banda	
	17	8000 49642	1	Fascetta	Clamp	Collier	Schelle	Banda	
	18	8A00 59596	1	Interruttore livello olio	Oil level switch	Interrupteur du niveau d'huile	Schalter Oelstand	Interruptor nivel aceite	
	19	8A00 77910	1	Serbatoio olio acqua	Oil tank	Reservoir huile	Öltank	Depósito aceite	
	20	8000 53717	1	Tappo	Plug	Bouchon	Verschluss	Tapón	
	22	8000 23118	1	Guarnizione OR	"OR" Gasket	Garniture "OR"	O Ring Dichtung	Junta OR	
	23	8000 56722	1	Guarnizione	Gasket	Garniture	Dichtung	Junta	
	24	8000 71414	1	Tampone ritegno serbatoio	Pad	Tampon	Stpfen	Tampòn	

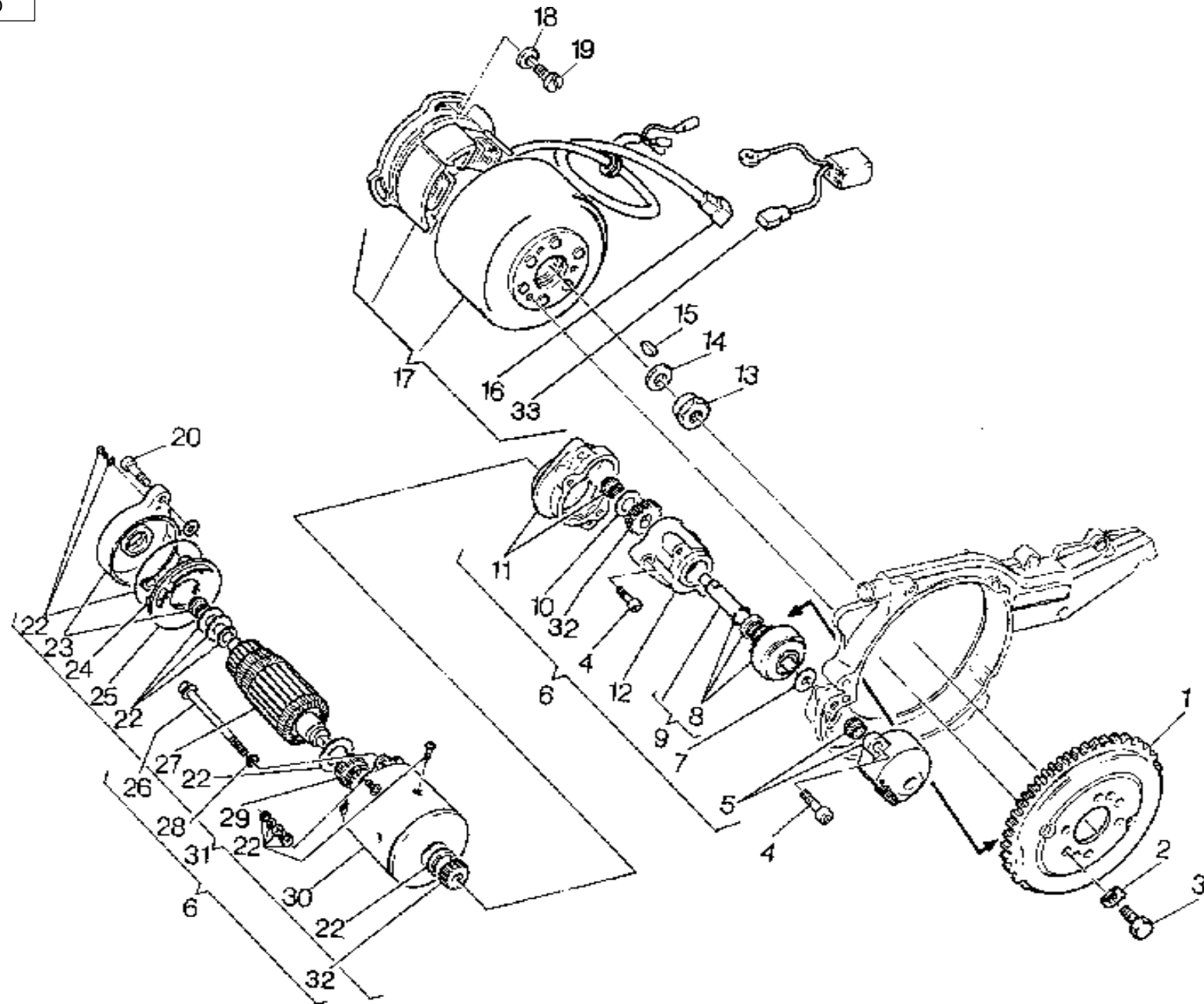

Note Notes Notas	Pos. No. N. Index Pos.	N° Codice Code No. Nr. Code Code Nr N. Cod.	Q.tà Q.ty Q.te M.ge C.ad	DENOMINAZIONE	NAME	DESIGNATION	BESHREIBUNG	DENOMINACION	Validità Validity Validité Gültig Valides
	1	8000 47374	1	Corona	Soricket	Couronne	Kranz	Corona	
	2	8000 48878	3	Rosetta	Washer	Rondelle	Scheibe	Arandela	
	3	8000 49628	3	Vite	Screw	Vis	Schraube	Tornillo	
	4	60N1 07335	2	Vite	Screw	Vis	Schraube	Tornillo	
	5	8000 50045	1	Coperchio	Cover	Couvercle	Deckel	Tapa	
	6	8000 47373	1	Ass. motorino avv. elettrico	Start motor	Moteur démarrage	Selbstarter	Motor arranque eléctrico	
	7	8G00 31756	1	Rasamento sp. 0,3 mm.	Thrust	Épaulement	Ausgleich	Rasadura	
	8	8000 47676	1	Serie molla, anello arr.elastico	Kit sprins, seal ring, elastic ring	Kit de ressort, bague d'etan	Kit Feder, Dichtung und elast.	Serie resorte, anillo de suje.	
	9	8000 47675	1	Rinvio completo	Transmission, compl.	Compl. transmission	Vorgelege,Kpl.	Reenvío compl.	
	10	8000 50043	1	Rosetta	Washer	Rondelle	Scheibe	Arandela	
	11	8000 50044	1	Flangia di riduzione compl.	Flange	Bride	Flansch	Brida	
	12	8000 47381	1	Distanziale	Spacer	Entretoise	Distanzstück	Separador	
	13	8000 42023	1	Dado	Nut	Ecrou	Mutter	Tuerca	
	14	8000 66565	1	Rosetta	Washer	Rondelle	Scheibe	Arandela	
	15	65N0 21002	1	Linguetta	Woodruff key	Clé woodruff	Federkeil	Lengüeta	
	16	8000 11577	1	Connettore a 2 vie	Connector	Connecteur	Verbinder	Conector	
	17	8000 59030	1	Volano elettronico compl.	Flywheel	Volant	Schwungrad	Volante	
	18	62N1 15766	3	Rosetta	Washer	Rondelle	Scheibe	Arandela	
	19	60N1 02901	3	Vite	Screw	Vis	Schraube	Tornillo	
	20	60N1 02509	4	Vite	Screw	Vis	Schraube	Tornillo	
	22	8000 47677	1	Serie rosette e guarnizioni	Washer and gasket kit	Kid de rondelles et Joints	Scheibe und Dichtungskit	Seire arandelas juntas	
	23	8000 47670	1	Supporto	Support	Support	Halterung	Soporte	
	24	8000 51726	2	Spazzole	Brush	Balai	Kohlen	Escobillas	
	25	8000 47672	1	Portaspazzole con molla	Brusch holder	Porte balai	Bürstenhalter	Porta escobillas con resortes	
	26	8000 47679	2	Tirante	Tie rod	Tirant	Spannstange	Tirante	
	27	8000 47674	1	Indotto	Armature	Induit	Anker	Inductor	
	28	62N1 15536	2	Rosetta	Washer	Rondelle	Scheibe	Arandela	
	29	8000 50251	1	Cuscinetto a rullini	Needle bearing	Roulement à aiguilles	Nadelkäfig	Cojinete	
	30	8000 47673	1	Campo induttore compl.	Inductor field assy	Champ inducteur compl.	Induktorfeld	Campo inductor compl.	
	31	8000 50042	1	Motorino senza rinvi	Start motor	Moteur démarrage	Selbstarter	Motor de arranque sin reenvíos	
	32	8000 65575	1	Coppia ingranaggio rinvio	Twing idle gears with spring ring	Couple d'engrenage de	Vorgelegeraderpaar mit	Par engranaje trasmisión	
	33	8000 66550	1	Cavo volano centralina	Cable	Cable	Kabel	Cable	

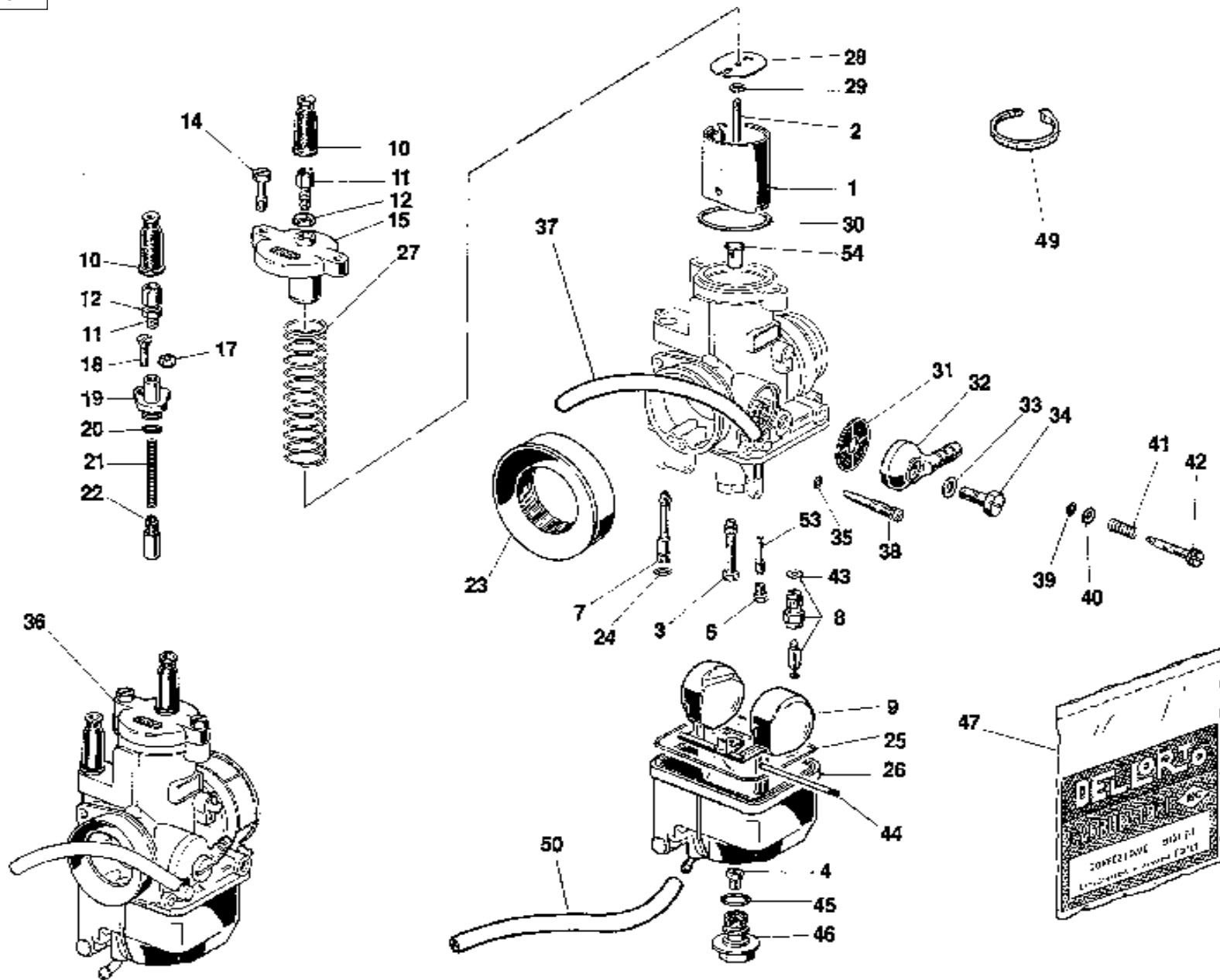

Note Notes Notas	Pos. No. N. Index Pos.	N° Codice Code No. Nr. Code Code Nr N. Cod.	Q.tà Q.ty Q.te M.ge C.ad	DENOMINAZIONE	NAME	DESIGNATION	BESHREIBUNG	DENOMINACION	Validità Validity Validité Gültig Valides
	1	80D0 36681	1	Valvola gas da 45	Throttle valve 45	Soupape gaz 45	Drosselkappe 45	Válvula 45	
	2	80S0 36683	1	Spillo conico 3° tacca	Needle X3	Pointeau conique X3	Kon. Nadel X3	Pasador cónico X3	
	3	8A00 49525	1	Polverizzatore BN 270	Fuel nozzle BN 270	Pulvérisateur BN 270	Einspritzdüse BN 270	Pulverizador BN 270	
	4	80A0 12041	1	Getto massimo 110	Main jet 110	Gicleur principal 110	Hauptdüse 110	Chiclé máximo 110	
	6	8C00 87148	1	Getto minimo 65	Idle jet 65	Gicleur minimum 65	Leerlaufdüse 65	Chiclé mínimo 65	
	7	80F0 12032	1	Getto avviamento 65	Starting jet 65	Gicleur de starter 65	Starterdüse 65	Chiclé arranque 65	
	8	8000 33109	1	Valvola a spillo 300	Needle valve 300	Soupape à pointeau 300	Nadelventil 300	Válvula de aguja 300	
	9	80C0 35357	1	Galleggiante g 9,5	Float 9,5g	Flotteur 9,5g	Schwimmer 9,5g	Flotador 9,5g	
	10	8000 58660	2	Cappuccio cavo	Cap	Capuchon	Kappe	Capuchón cable	
	11	8000 87563	2	Vite	Screw	Vis	Schraube	Tornillo	
	12	8000 51987	2	Dado	Nut	Ecrou	Mutter	Tuerca	
	14	8000 23981	2	Vite	Screw	Vis	Schraube	Tornillo	
	15	8000 36685	1	Coperchio valvola gas	Throttle valve cover	Couvercle papillon de gaz	Drosselkappe Deckel	Tapa válvula acelerador	
	17	8000 04104	1	Dado	Nut	Ecrou	Mutter	Tuerca	
	18	8000 32855	1	Vite	Screw	Vis	Schraube	Tornillo	
	19	8000 40582	1	Coperchio	Cover	Couvercle	Deckel	Tapa	
	20	X	1	Guarnizione dispos. avv.	Gasket	Garniture	Dichtung	Junta	
	21	8000 44043	1	Molla	Spring	Ressort	Feder	Resorte	
	22	8000 40580	1	Valvola avviamento	Starter valve	Soupape de démarrage	Startventil	Válvula	
	23	8000 36687	1	Raccordo	Union	Raccord	Anschluss	Empalme	
	24	X	1	Guarnizione getto avviamento	Gasket	Garniture	Dichtung	Junta	
	25	X	1	Guarnizione vaschetta	Gasket	Garniture	Dichtung	Junta	
	26	8000 79936	1	Vaschetta	Chamber	Cuvette	Becken	Cubeta	
	27	8000 35086	1	Molla	Spring	Ressort	Feder	Resorte	
	28	8000 36682	1	Piastrina	Plate	Plaquette	Plättchen	Placa	
	29	8000 35353	1	Fermaglio spillo conico	Retainer	Arret	Klammer	Pasador cónico	
	30	X	1	Guarnizione coperchio	Gasket	Garniture	Dichtung	Junta tapa válvulas	
	31	8000 12045	1	Filtro benzina	Fuel filter	Filtre essence	Benzinfilter	Filtro gasolina	
	32	8000 57436	1	Pipetta	Pipette	Pipette	Pipette	Pipa	
	33	X	1	Guarnizione vite	Gasket	Garniture	Dichtung	Junta	
	34	8000 57437	1	Vite	Screw	Vis	Schraube	Tornillo	
	35	X	1	Guarnizione vite	Gasket	Garniture	Dichtung	Junta	

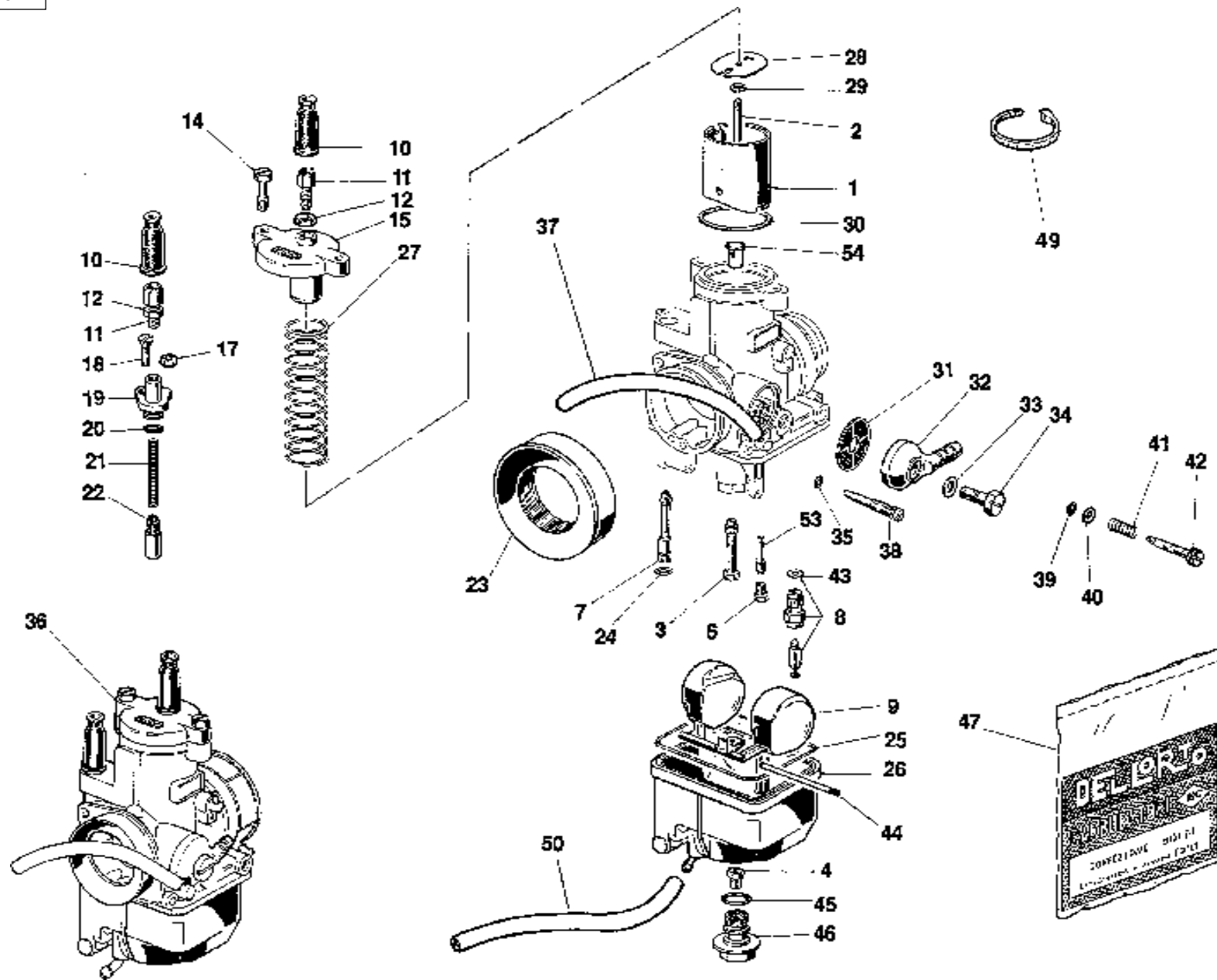

Note Notes Notas	Pos. No. N. Index Pos.	N° Codice Code No. Nr. Code Code Nr N. Cod.	Q.tà Q.ty Q.te M.ge C.äd	DENOMINAZIONE	NAME	DESIGNATION	BESHREIBUNG	DENOMINACION	Validità Validity Validité Gültig Valides
	36	8000 87572	1	Assieme carburatore	Carburetor assy	Carburateur complet	Vegaser, kpl.	Carburador compl.	
	37	8A00 55507	2	Tubetto	Pipe	Tuyau	Rohr	Tubo	
	38	8000 64169	1	Vite	Screw	Vis	Schraube	Tornillo	
	39	X	1	Guarnizione vite	Gasket	Garniture	Dichtung	Junta	
	40	8000 23983	1	Rondella piana	Washer	Rondelle	Unterlegscheibe	Arandela plana	
	41	8000 12030	1	Molla	Spring	Ressort	Feder	Resorte	
	42	8000 12029	1	Vite	Screw	Vis	Schraube	Tornillo	
	43	X	1	Guarnizione valvola a spillo	Gasket	Garniture	Dichtung	Junta	
	44	8000 12037	1	Perno galleggiante	Pin	Pivot	Bolzen	Perno	
	45	X	1	Guarnizione tappo	Gasket	Garniture	Dichtung	Junta	
	46	8000 49531	1	Tappo	Plug	Bouchon	Verschluss	Tapòn	
	47	8000 64170	1	Gruppo guarnizioni	Gasket set	Groupe garniture	Dichtungssatz	Grupo junta	
	49	8000 21810	1	Fascetta	Clamp	Collier	Schelle	Banda	
	50	8D00 55507	1	Tubo scarico benzina	Pipe	Tuyau	Rohr	Tubo	
	53	80D0 63846	1	Emulsionatore da 65	Emulsifier	Emulsionneur	Mischer	Emulsionador	
	54	8000 87150	1	Ugello polverizzatore 7mm	Spray nozzle	Buse àtomiseur	Einspritzdüse	Injectör pulverizadör	
		X		Contenuto nella busta guarnizioni (47)	It's contained in the gasket set (47)	Contenu entre l'enveloppe du joints (47)	In den reparaturenrichtung satz (47)	En el saquito de guarnic. (47)	

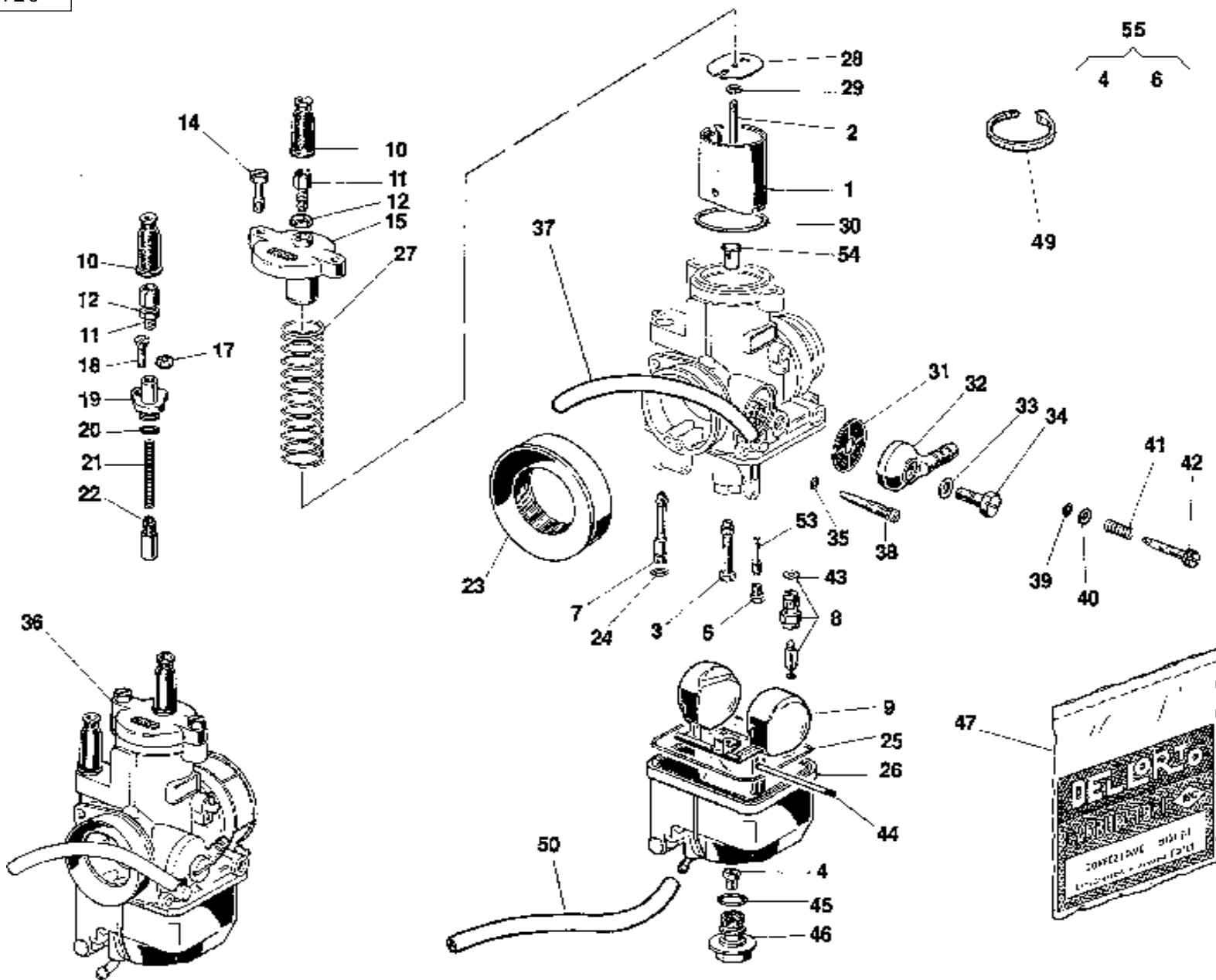

Note Notes Notas	Pos. No. N. Index Pos.	N° Codice Code No. Nr. Code Code Nr N. Cod.	Q.tà Q.ty Q.te M.ge C.ad	DENOMINAZIONE	NAME	DESIGNATION	BESHREIBUNG	DENOMINACION	Validità Validity Validité Gültig Valides
	1	8000 67919	1	Valvola a gas da 50	Throttle valve	Soupape gaz	Drosselkappe	Válvula	
	2	80IO 36683	1	Spillo conico x 58/1	Needle x 58/1	Pointeau conique x 58/1	Kon. Nadel x 58/1	Pasador cónico x 58/1	
	3	8000 67920	1	Polverizzatore 266 DU1	Fuel nozzle 266 DV1	Pulvérisateur 266 DV1	Einspritzdüse 266 DV1	Pulverizador 266 DV1	
	4	80EO 12041	1	Getto massimo 120	Main jet 120	Gicleur principal 120	Hauptdüse 120	Chiclé máximo 120	
D	4	8AD0 12041	1	Getto massimo 140	Main jet 140	Gicleur principal 140	Hauptdüse 140	Chiclé máximo 140	
K	4	8IO0 12041	1	Getto massimo 130	Main jet 130	Gicleur principal 130	Hauptdüse 130	Chiclé máximo 130	
	5	80BO 57400	1	Getto potenza 90	Power jet 90	Gicler puissance 90	Leistungdüse 90	Chiclé potencia 90	
	6	8DF0 05761	1	Getto minimo 38	Idle jet 38	Gicleur minimum 38	Leerlaufdüse 38	Chiclé mínimo 38	
D	6	8AD0 05761	1	Getto minimo 48	Idle jet 48	Gicleur minimum 48	Leerlaufdüse 48	Chiclé mínimo 48	
K	6	8AD0 05761	1	Getto minimo 48	Idle jet 48	Gicleur minimum 48	Leerlaufdüse 48	Chiclé mínimo 48	
	7	80F0 12032	1	Getto avviamento 65	Starting jet 65	Gicleur de starter 65	Starterdüse 65	Chiclé arranque 65	
	8	80CO 35356	1	Valvola a spillo 200	Needle valve 200	Soupape à pointeau 200	Nadelventil 200	Válvula de aguja 200	
	9	8000 35357	1	Galleggiante g 9,5	Float 9,5g	Flotteur 9,5g	Schwimmer 9,5g	Flotador 9,5g	
	10	8000 58660	2	Cappuccio cavo	Cap	Capuchon	Kappe	Capuchón cable	
	11	8000 51986	2	Vite	Screw	Vis	Schraube	Tornillo	
	12	8000 51987	2	Dado	Nut	Ecrou	Mutter	Tuerca	
	14	8000 23981	2	Vite	Screw	Vis	Schraube	Tornillo	
	15	8000 36685	1	Coperchio valvola gas	Throttle valve cover	Couvercle papillon de gaz	Drosselkappe Deckel	Tapa válvula acelerador	
	17	8000 04104	1	Dado	Nut	Ecrou	Mutter	Tuerca	
	18	8000 32855	1	Vite	Screw	Vis	Schraube	Tornillo	
	19	8000 40582	1	Coperchio	Cover	Couvercle	Deckel	Tapa	
	20	X	1	Guarnizione dispos. avv.	Gasket	Garniture	Dichtung	Junta	
	21	8000 44043	1	Molla	Spring	Ressort	Feder	Resorte	
	22	8000 40580	1	Valvola avviamento	Starter valve	Soupape de démarrage	Startventil	Válvula	
	23	8000 36687	1	Raccordo	Union	Raccord	Anschluss	Empalme	
	24	X	1	Guarnizione getto avviamento	Gasket	Garniture	Dichtung	Junta	
	25	X	1	Guarnizione vaschetta	Gasket	Garniture	Dichtung	Junta	
	26	8000 64168	1	Vaschetta	Chamber	Cuvette	Becken	Cubeta	
	27	8000 35086	1	Molla	Spring	Ressort	Feder	Resorte	
	28	8000 36682	1	Piastrina	Plate	Plaquette	Plättchen	Placa	
	29	8000 35353	1	Fermaglio spillo conico	Retainer	Arret	Klammer	Pasador cónico	
	30	X	1	Guarnizione coperchio	Gasket	Garniture	Dichtung	Junta tapa válvulas	

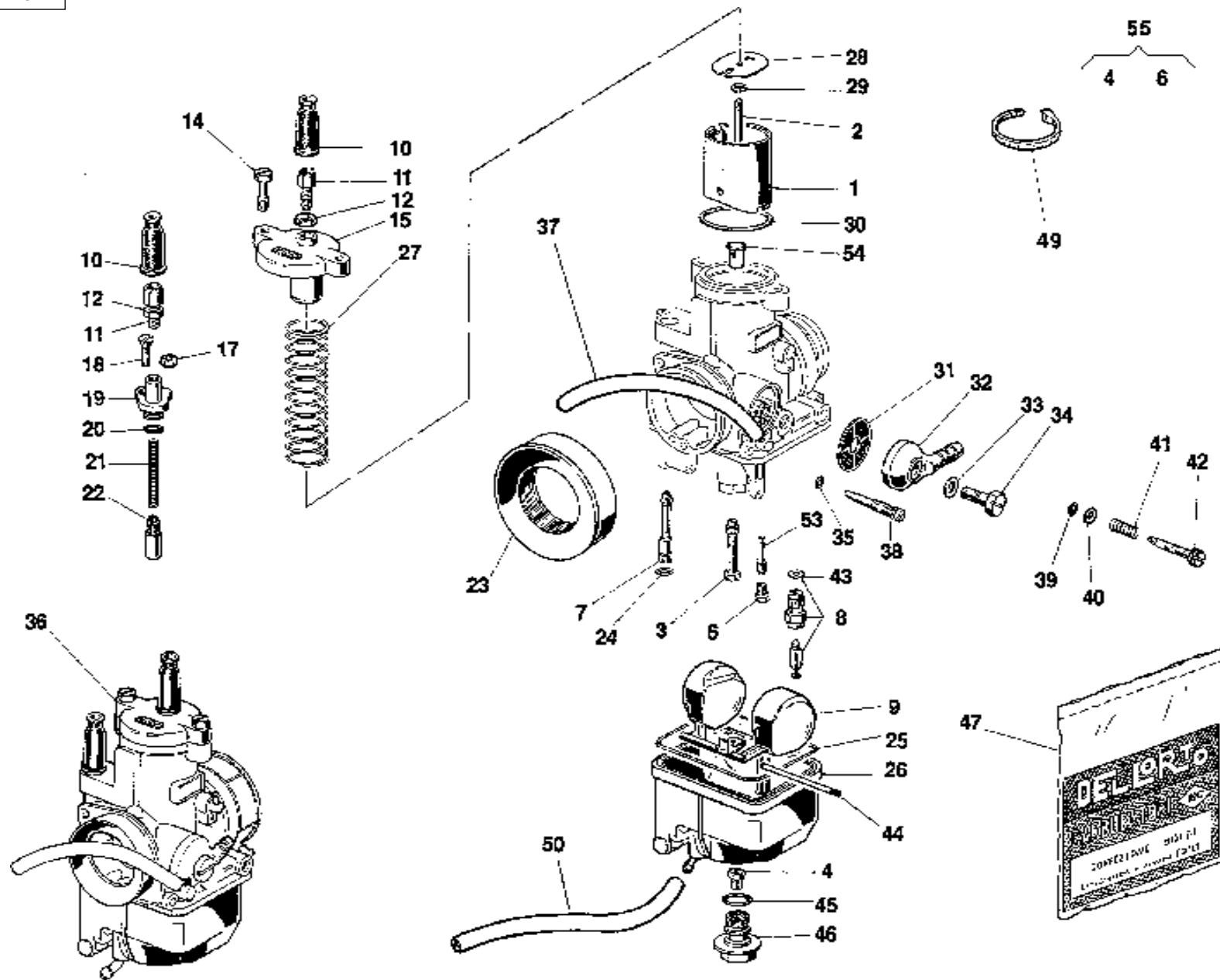

Note Notes Notas	Pos. No. N. Index Pos.	N° Codice Code No. Nr. Code Code Nr N. Cod.	Q.tà Q.ty Q.te M.ge C.ad	DENOMINAZIONE	NAME	DESIGNATION	BESHREIBUNG	DENOMINACION	Validità Validity Validité Gültig Valides
	31	8000 12045	1	Filtro benzina	Fuel filter	Filtre essence	Benzinfilter	Filtro gasolina	
	32	8000 57436	1	Pipetta	Pipette	Pipette	Pipette	Pipa	
	33	X	1	Guarnizione vite	Gasket	Garniture	Dichtung	Junta	
	34	8000 57437	1	Vite	Screw	Vis	Schraube	Tornillo	
	35	X	1	Guarnizione vite	Gasket	Garniture	Dichtung	Junta	
	36	8000 89819	1	Assieme carburatore	Carburetor assy	Carburateur complet	Vegaser, kpl.	Carburador compl.	
	37	8000 52078	1	Tubetto	Pipe	Tuyau	Rohr	Tubo	
	38	8000 64169	1	Vite	Screw	Vis	Schraube	Tornillo	
	39	X	1	Guarnizione vite	Gasket	Garniture	Dichtung	Junta	
	40	8000 23983	1	Rondella piana	Washer	Rondelle	Unterlegscheibe	Arandela plana	
	41	8000 12030	1	Molla	Spring	Ressort	Feder	Resorte	
	42	8000 12029	1	Vite	Screw	Vis	Schraube	Tornillo	
	43	X	1	Guarnizione valvola a spillo	Gasket	Garniture	Dichtung	Junta	
	44	8000 12037	1	Perno galleggiante	Pin	Pivot	Bolzen	Perno	
	45	X	1	Guarnizione tappo	Gasket	Garniture	Dichtung	Junta	
	46	8000 49531	1	Tappo	Plug	Bouchon	Verschluss	Tapòn	
	47	8000 64170	1	Gruppo guarnizioni	Gasket set	Groupe garniture	Dichtungssatz	Grupo junta	
	48	8A00 55507	2	Tubetto	Pipe	Tuyau	Rohr	Tubo	
	49	8000 21810	1	Fascetta	Clamp	Collier	Schelle	Banda	
	50	8A00 55507	1	Tubo scarico benzina	Pipe	Tuyau	Rohr	Tubo	
	52	X	1	Guarnizione	Gasket	Garniture	Dichtung	Junta	
	53	80A0 40583	1	Emulsionatore	Emulsifier	Emulsionneur	Mischer	Emulsionador	
	54	8000 60461	1	Ugello polverizzatore	Spray nozzle	Buse àtomizeur	Einspritzdüse	Injectòr pulverizadòr	
K	55	8000 92713	1	Kit potenziamento	Power improvement kit	Kit de poissance	Kit Potenz	Kit potencia	
X				Contenuto nella busta guarnizioni (47)	It's contained in the gasket set (47)	Contenu entre l'enveloppe du joints (47)	In den reparaturenrichtung satz (47)	En el saquito de guarnic. (47)	
D				In dotazione	To issue	En necessaire	Ausrüstungsteile	En dotacion	
K				Contenuto nel kit potenziamento n° 8000 92713	It's contained in power improvement kit No 8000 92713	Contenu en le kit de poissance nr. 8000 92713	In den reparaturenrichtung Kit Potenz Nr. 8000 92713	Es contenido en el kit de potencia N. 8000 92713	

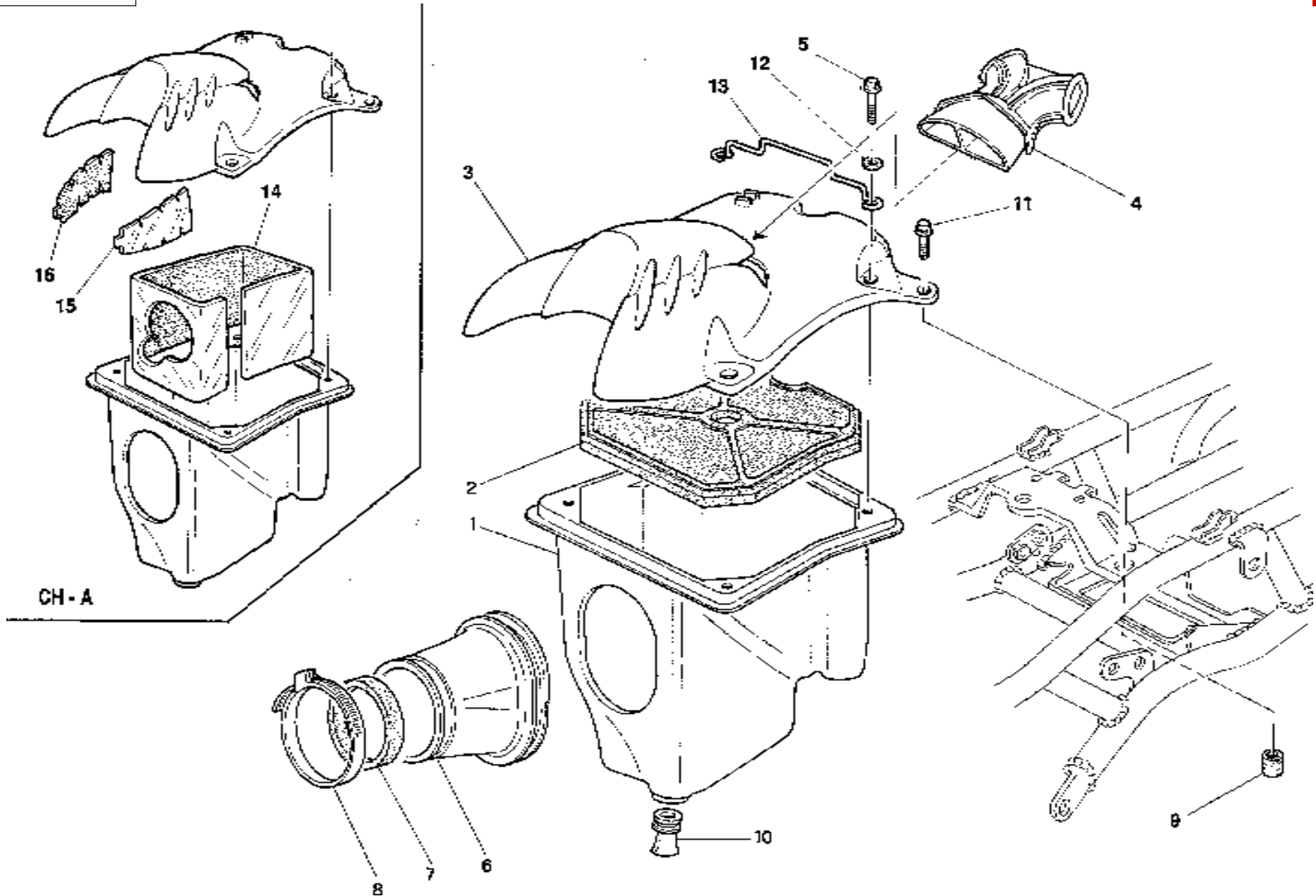

Note Notes Notas	Pos. No. N. Index	N° Codice Code No. Nr. Code Code Nr N. Cod.	Q.tà Q.ty Q.te M.ge C.ad	DENOMINAZIONE	NAME	DESIGNATION	BESHREIBUNG	DENOMINACION	Validità Validity Validité Gültig Valides
	1	8000 66506	1	Scatola filtro	Air filter box	Boite pour filtre	Luftfiltergehäuse	Caja Filtro aire	
	2	8000 66507	1	Filtro	Filter	Filtre	Filter	Filtro	
	3	8000 85831	1	Coperchio	Cover	Couvercle	Deckel	Tapa	
	4	8000 88002	1	Raccordo	Union	Raccord	Anschluss	Empalme	
	5	8000 62728	4	Vite	Screw	Vis	Schraube	Tornillo	
	6	8000 66510	1	Raccordo	Union	Raccord	Anschluss	Empalme	
	7	8000 67171	1	Anello	Ring	Bague	Ring	Anillo	
	8	8C00 68666	1	Fascetta	Clamp	Collier	Schelle	Banda	
	9	8000 48245	2	Dado elastico	Elastic nut	Ecrou	Mutter	Tuerca	
	10	8000 48971	1	Gommino	Rubber pad	Pièce caoutchouc	Gummistück	Junta de goma	
	11	8000 62728	2	Vite	Screw	Vis	Schraube	Tornillo	
	12	8000 04898	4	Rosetta	Washer	Rondelle	Scheibe	Arandela	
	13	8000 88323	1	Passacavo	Fairlead	Passacâble	Kabelführung	Prensacable	
	14	8000 68861	1	Pannello insonorizzante (CH-A)	Sound proofing panel (CH-A)	Panneau isolant phonique (CH-A)	Schalldämpfungspanel (CH-A)	Panel isolador acústico (CH-A)	
	15	8000 90199	1	Pannello insonorizzante Sx (CH-A)	L.H. sound proofing panel (CH-A)	Panneau isolant phonique G. (CH-A)	Schalldämpfungspanel Linke (CH-A)	Panel isolador acústico iz. (CH-A)	
	16	8000 90198	1	Pannello insonorizzante Dx (CH-A)	R.H. sound proofing panel (CH-A)	Panneau isolant phonique D. (CH-A)	Schalldämpfungspanel Recht (CH-A)	Panel isolador acústico der. (CH-A)	

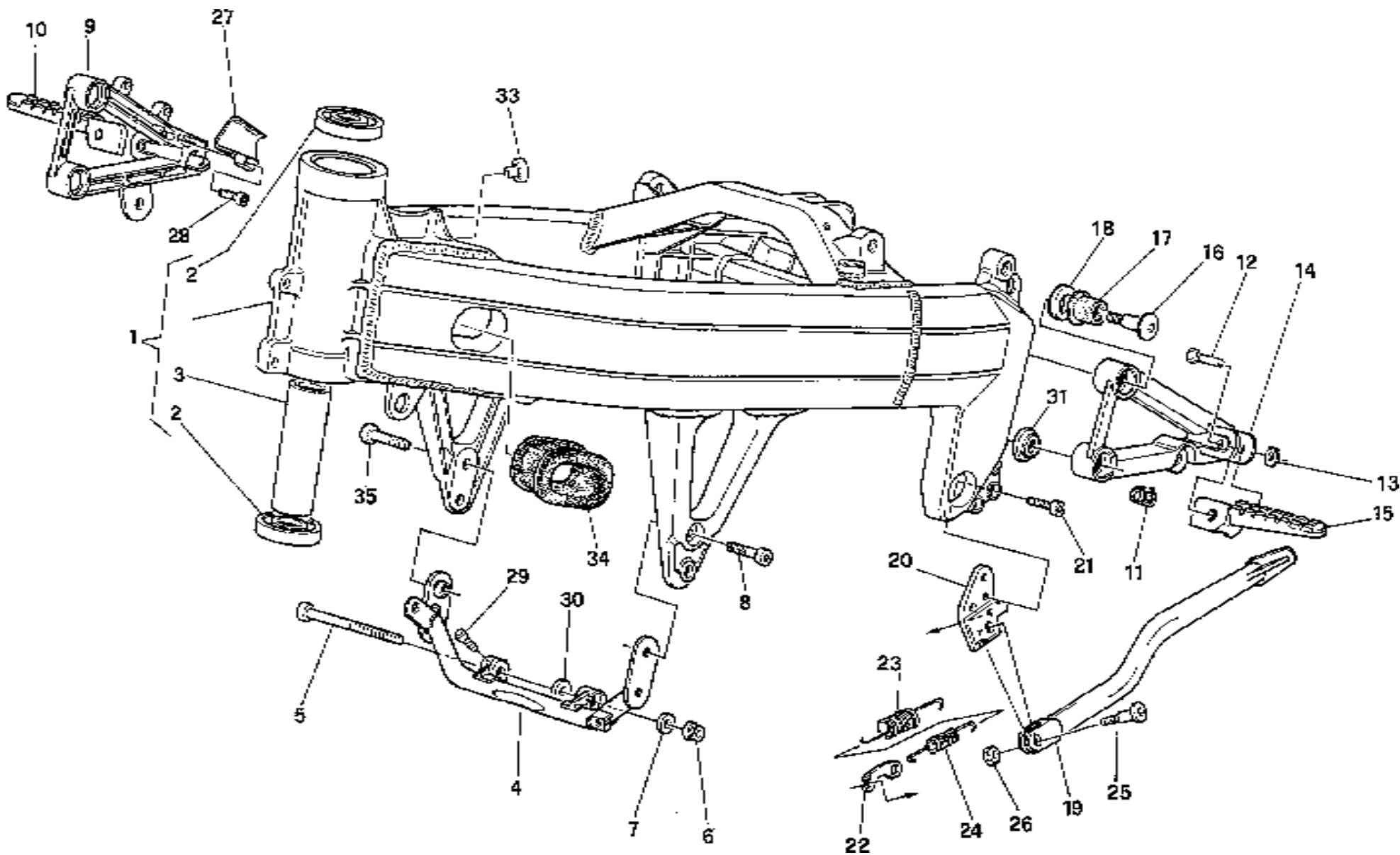

Note Notes Notas	Pos. No. N. Index Pos.	N° Codice Code No. Nr. Code Code Nr N. Cod.	Q.tà Q.ty Q.te M.ge C.ad	DENOMINAZIONE	NAME	DESIGNATION	BESHREIBUNG	DENOMINACION	Validità Validity Validité Gültig Valides
	1	8000 85729	1	Assieme telaio (codice colore A B C = 8G42)	Frame assy (Colour code A B C = 8G42)	Cadre compl. (code couleur A B C = 8G42)	Kpl., Rahmen (Code Farbe A B C = 8G42)	Bastidor compl. (còdigo colòr A B C = 8G42)	
	1	8000 90337	1	Ass.telaio (codice colore D = 8E44)	Frame, assy (Colour code D = 8E44)	Cadre complete (code couleur D = 8E44)	Kpl., Rahmen (Code Farbe D = 8E44)	Bastidor compl. (còdigo colòr D = 8E44)	
	1	8000 92417	1	Ass.telaio (codice colore E = 8E63)	Frame, assy (Colour code E = 8E63)	Cadre complete (code couleur E = 8E63)	Kpl., Rahmen (Code Farbe E = 8E63)	Bastidor compl. (còdigo colòr E = 8E63)	
	1	8A00 92417	1	Ass.telaio (codice colore F = 8E63)	Frame, assy (Colour code F = 8E63)	Cadre complete (code couleur F = 8E63)	Kpl., Rahmen (Code Farbe F = 8E63)	Bastidor compl. (còdigo colòr F = 8E63)	
	1	8B00 92417	1	Ass.telaio (codice colore G = 8E63)	Frame, assy (Colour code G = 8E63)	Cadre complete (code couleur G = 8E63)	Kpl., Rahmen (Code Farbe G = 8E63)	Bastidor compl. (còdigo colòr G = 8E63)	
	1	8A00 85729	1	Ass.telaio (codice colore H L = 8A15)	Frame, assy (Colour code H L = 8A15)	Cadre complete (code couleur H L = 8A15)	Kpl., Rahmen (Code Farbe H L = 8A15)	Bastidor compl. (còdigo colòr H L = 8A15)	
	2	8000 22672	2	Cuscinetto	Bearing	Roulement	Lager	Cojinete	
	3	8000 53554	1	Distanziale	Spacer	Entretoise	Distanzstück	Separador	
	4	8000 87012	1	Traversino	Cross member	Traverse	Traverse	Travesaño	
	5	8000 67987	1	Vite	Screw	Vis	Schraube	Tornillo	
	6	8000 43928	2	Dado	Nut	Ecrou	Mutter	Tuerca	
	7	8E00 05893	1	Rosetta piana	Washer	Rondelle	Scheibe	Arandela	
	8	60N1 02555	3	Vite	Screw	Vis	Schraube	Tornillo	
	9	80A0 85740	1	Supporto destro (cod. colore A B C D H L= 8E14)	Support (Colour cod. A B C D H L= 8E14)	Support (cod. couleur A B C D H L= 8E14)	Halterung (Cod. Farbe A B C D H L= 8E14)	Soporte (còd. colòr A B C D H L= 8E14)	
	9	80B0 85740	1	Supporto destro (cod. colore E F G = 8E63)	Support (Colour cod. E F G = 8E63)	Support (cod. couleur E F G = 8E63)	Halterung (Cod. Farbe E F G = 8E63)	Soporte (còd. colòr E F G = 8E63)	
	10	8000 94670	1	Pedana anteriore destra	Foot rest	Repose pieds	Fussraste	Pedal delnt. derech. compl.	
	11	8000 60700	2	Molla	Spring	Ressort	Feder	Resorte	
	12	80A0 53546	2	Perno	Pin	Pivot	Bolzen	Perno	
	13	66N1 21308	2	Anello seeger	Seeger ring	Bague seeger	Seegerring	Anillo Seeger	
	14	80A0 85739	1	Supporto sinistro (cod. colore A B C D H L= 8E14)	Support (Colour cod. A B C D H L= 8E14)	Support (cod. couleur A B C D H L= 8E14)	Halterung (Cod. Farbe A B C D H L= 8E14)	Soporte (còd. colòr A B C D H L= 8E14)	
	14	80B0 85739	1	Supporto sinistro (cod. colore E F G = 8E63)	Support (Colour cod. E F G = 8E63)	Support (cod. couleur E F G = 8E63)	Halterung (Cod. Farbe E F G = 8E63)	Soporte (còd. colòr E F G = 8E63)	
	15	8000 94669	1	Pedana anteriore sinistra	Foot rest	Repose pieds	Fussraste	Pedal delnt. derech. compl.	

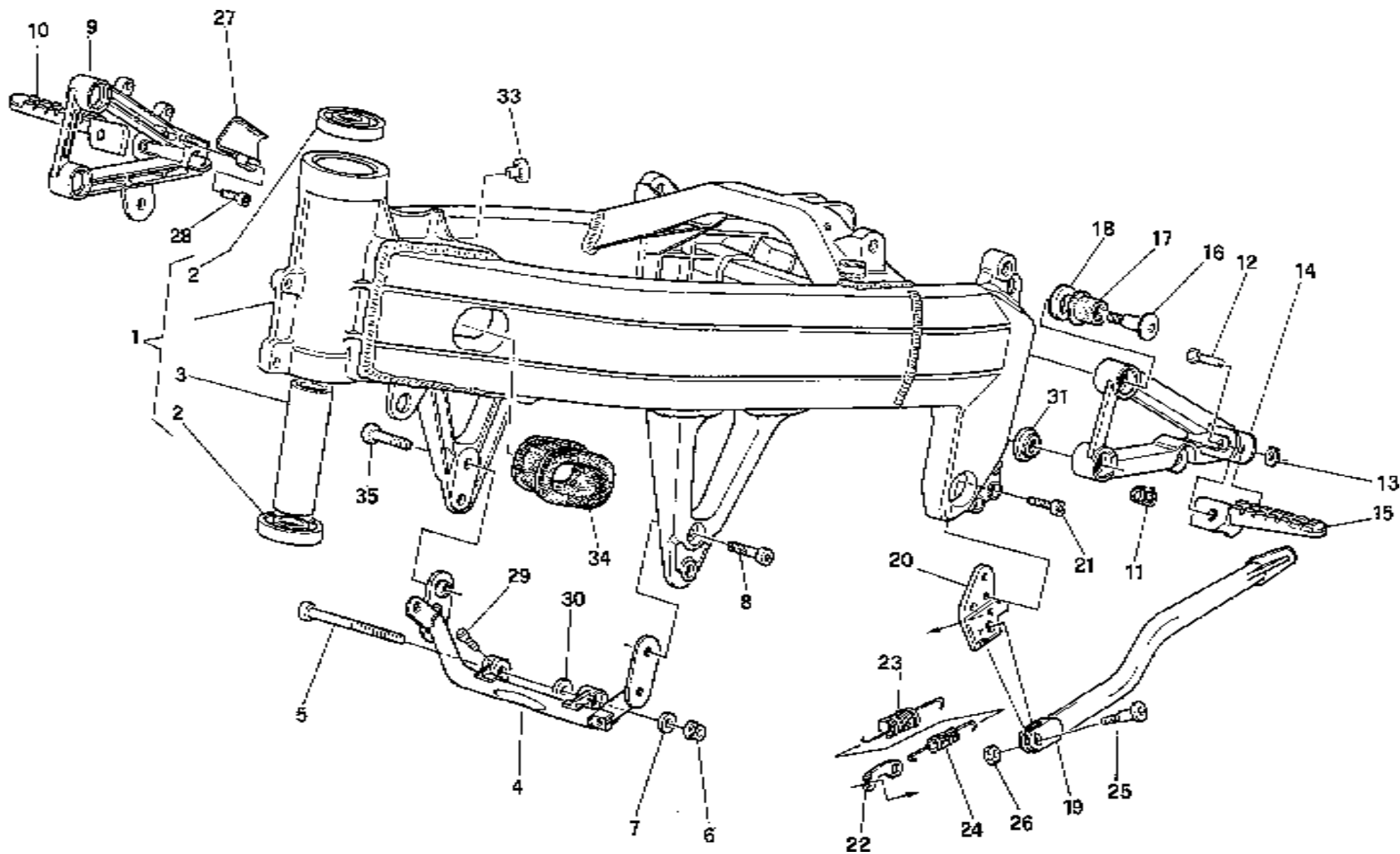

Note Notes Notas	Pos. No. N. Index Pos.	N° Codice Code No. Nr. Code Code Nr N. Cod.	Q.tà Q.ty Q.te M.ge C.ad	DENOMINAZIONE	NAME	DESIGNATION	BESHREIBUNG	DENOMINACION	Validità Validity Validité Gültig Valides
	16	8000 62568	4	Vite	Screw	Vis	Schraube	Tornillo	
	17	8000 60683	4	Silent block	Silent block	Silent block	Silentblock	Silentblock	
	18	80A0 25363	2	Rondella (codice colore A B C D E F G)	Washer (Colour code A B C D E F G)	Rondelle (code couleur A B C D E F G)	Scheibe (Code Farbe A B C D E F G)	Arandela (còdigo colòr A B C D E F G)	
	18	80A0 25363	4	Rondella (codice colore H L)	Washer (Colour code H L)	Rondelle (code couleur H L)	Scheibe (Code Farbe H L)	Arandela (còdigo colòr H L)	
	19	8000 60693	1	Gamba laterale	Side stand	Bequille lat.	Seitenständer	Horquilla lateral	
	20	8000 62592	1	Piastra	Plate	Plaque	Platte	Placa	
	21	60N1 02555	3	Vite	Screw	Vis	Schraube	Tornillo	
	22	8000 62644	1	Piastrina	Plate	Plaquette	Plättchen	Placa	
	23	8000 62675	1	Molla esterna	Spring	Ressort	Feder	Resorte	
	24	8000 62676	1	Molla interna	Spring	Ressort	Feder	Resorte	
	25	8000 62595	1	Perno	Pin	Pivot	Bolzen	Perno	
	26	8000 43928	1	Dado	Nut	Ecrou	Mutter	Tuerca	
	27	8000 86528	1	Protezione	Guard	Protection	Schutz	Protección	
	28	8000 62725	1	Vite	Screw	Vis	Schraube	Tornillo	
	29	8G0090426	1	Vite	Screw	Vis	Schraube	Tornillo	
	30	8000 05893	1	Rosetta	Washer	Rondelle	Scheibe	Arandela	
	31	8000 87259	2	Distanziale (codice colore A B C D E F G)	Spacer (Colour code A B C D E F G)	Entretoise (code couleur A B C D E F G)	Distanzstück (Code Farbe A B C D E F G)	Separador (còdigo colòr A B C D E F G)	
	33	8000 78181	1	Tampone	Pad	Tampon	Stpfen	Tampòn	
	34	8000 67978	1	Manicotto	Sleeve	Manchon	Muffe	Manguito	
	35	80B0 52239	1	Vite	Screw	Vis	Schraube	Tornillo	

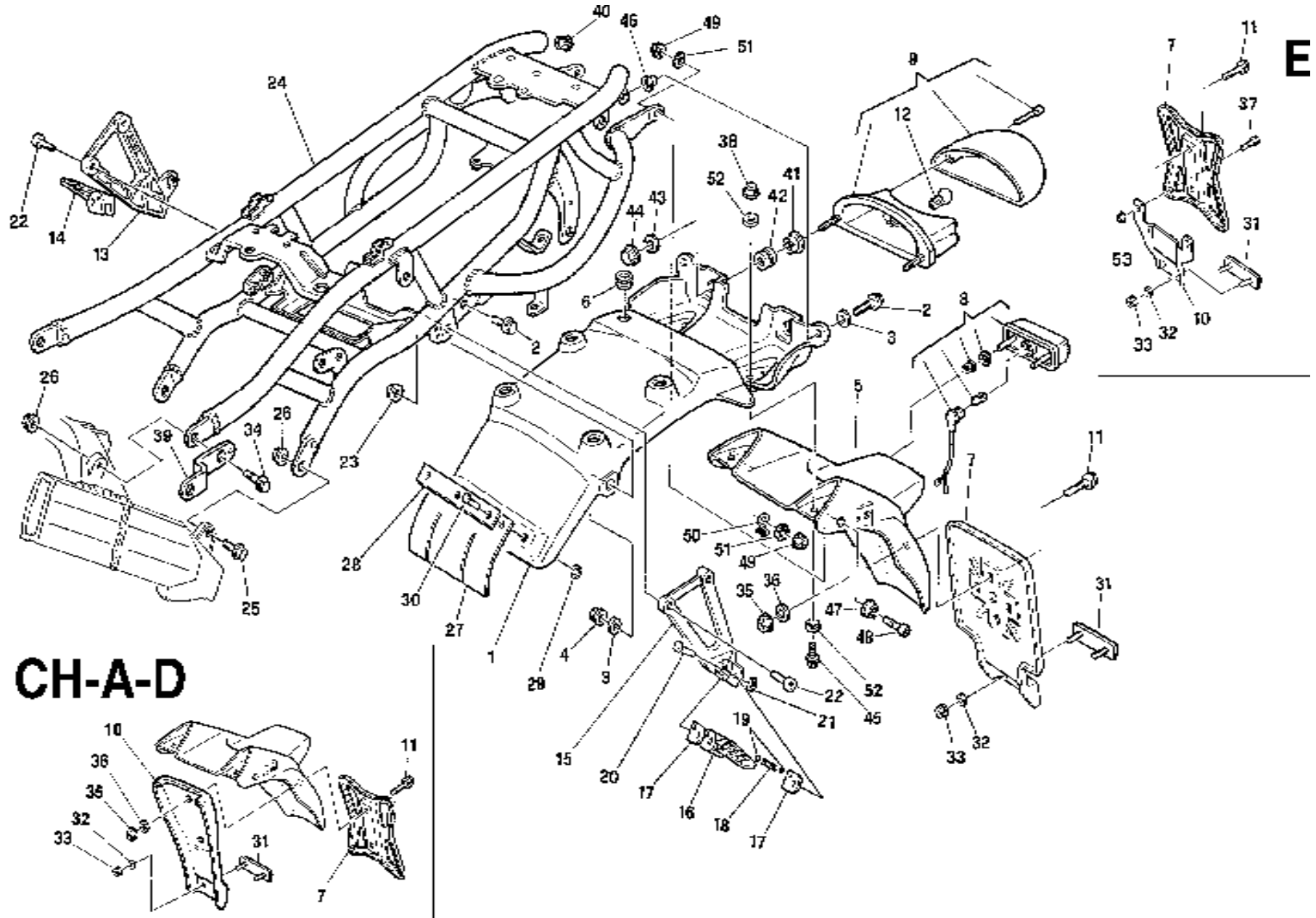

Note Notes Notas	Pos. No. N. Index Pos.	N° Codice Code No. Nr. Code Code Nr. N. Cod.	Q.tà Q.ty Q.te M.ge C.ad	DENOMINAZIONE	NAME	DESIGNATION	BESHREIBUNG	DENOMINACION	Validità Validity Validité Gültig Valides
	1	8000 85784	1	Parafango posteriore	Rear mudguard	Garde boue arriere	Hint.Kotfluegel	Guarda barro trasero	
	2	8000 62727	4	Vite	Screw	Vis	Schraube	Tornillo	
	3	8000 04898	4	Rondella piana	Washer	Rondelle	Unterlegscheibe	Arandela plana	
	4	8000 44240	6	Dado autobloccante	Nut	Ecrou	Mutter	Tuerca	
	5	8000 85834	1	Portatarga	Plate holder	Porte balai	Schildtraeger	Porta matrícula	
	6	8000 66449	1	Passacavo	Fairlead	Passe câble	Kabelführung	Prensa cable	
	7	8000 94595	1	Piastra	Plate	Plaque	Platte	Placa	
	7	8000 62700	1	Piastra (CH-A-D)	Plate (CH-A-D)	Plaque (CH-A-D)	Platte (CH-A-D)	Placa (CH-A-D)	
E	7	8000 62700	1	Piastra	Plate	Plaque	Platte	Placa	
	8	8000 86011	1	Fanalino	Tail light	Feu arriere	Rücklicht	Faro trasero	
	9	8000 85790	1	Fanale posteriore	Tail light	Feu arriere	Hinterlicht	Faro trasero	
E	10	8000 87696	1	Piastrina	Plate	Plaquette	Plättchen	Placa	
	10	8000 89860	1	Paraspruzzi (CH-A-D)	Rear end (CH-A-D)	Terminal (CH-A-D)	Hinterkiff (CH-A-D)	Para rociada (CH-A-D)	
	11	60N1 01080	2	Vite	Screw	Vis	Schraube	Tornillo	
	11	8000 65535	2	Vite (CH-A-D)	Screw (CH-A-D)	Vis (CH-A-D)	Schraube (CH-A-D)	Tornillo (CH-A-D)	
E	11	8C00 66525	2	Vite	Screw	Vis	Schraube	Tornillo	
	12	8000 18246	1	Lampada bilux12V 5/21W	Lamp	Lampe	Lampe	Lamparilla	
	13	80A0 85742	1	Supporto dx (cod. colore A B C D H L= 8E14)	R.H. holder (Colour cod. A B C D H L= 8E14)	Support D. (cod. couleur A B C D H L= 8E14)	Halter, R. (Cod. Farbe A B C D H L= 8E14)	Soporte der. (còd. colòr A B C D H L= 8E14)	
	13	80B0 85742	1	Supporto dx (cod. colore E F G = 8E63)	R.H. holder (Colour cod. E F G = 8E63)	Support D. (cod. couleur E F G = 8E63)	Halter, R. (Cod. Farbe E F G = 8E63)	Soporte der. (còd. colòr E F G = 8E63)	
	14	8000 94670	1	Pedana destra	R. foot rest	Repose pied D.	Fussraste R.	Pedal derech.	
	15	80B0 60699	1	Supporto sx (cod. colore A B C D H L= 8E14)	L.H. holder (Colour cod. A B C D H L= 8E14)	Support G. (cod. couleur A B C D H L= 8E14)	Halter, L. (Cod. Farbe A B C D H L= 8E14)	Soporte izq. (còd. colòr A B C D H L= 8E14)	
	15	80C0 60699	1	Supporto sx (cod. colore E F G = 8E63)	L.H. holder (Colour cod. E F G = 8E63)	Support G. (cod. couleur E F G = 8E63)	Halter, L. (Cod. Farbe E F G = 8E63)	Soporte izq. (còd. colòr E F G = 8E63)	
	16	8000 94669	1	Pedana sinistra	L. foot rest	Repose pied G.	Fussbrett L.	Pedal izquierdo	
	17	8000 A0070	2	Piastrina	Plate	Plaquette	Plättchen	Placa	
	18	8000 A0204	1	Molla	Spring	Ressort	Feder	Resorte	
	19	6BNO 21507	2	Sfera	Ball	Bille	Kugel	Esfera	
	20	80A0 53546	1	Perno	Pin	Pivot	Bolzen	Perno	
	21	66N1 21308	1	Anello seeger	Seeger ring	Bague seeger	Seegerring	Anillo Seeger	

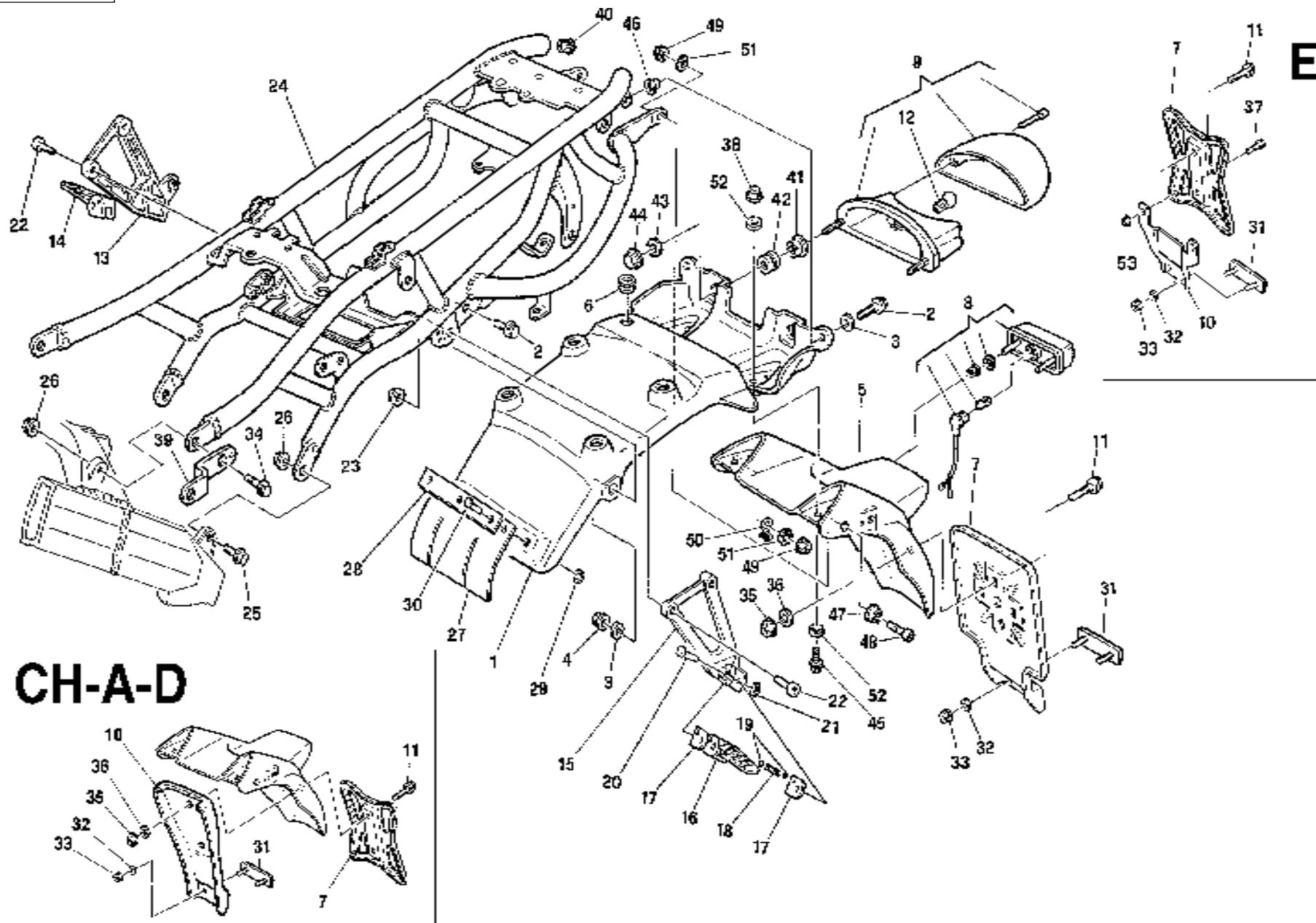

Note Notes Notas	Pos. No. N. Index Pos.	N° Codice Code No. Nr. Code Code Nr. N. Cod.	Q.tà Q.ty Q.te M.ge C.ad	DENOMINAZIONE	NAME	DESIGNATION	BESHREIBUNG	DENOMINACION	Validità Validity Validité Gültig Valides
	22	60N1 02555	4	Vite	Screw	Vis	Schraube	Tornillo	
	23	8000 43928	4	Dado autobloccante	Nut	Ecrou	Mutter	Tuerca	
	24	8000 86290	1	Telaio posteriore (8E14)	Rear frame side (8E14)	Chassis arrière (8E14)	Sattelbrücke (8E14)	Cuadro posterior (8E14)	
	25	8C00 69056	2	Vite	Screw	Vis	Schraube	Tornillo	
	26	8000 43928	4	Dado autobloccante	Nut	Ecrou	Mutter	Tuerca	
	27	8000 66312	1	Protezione	Guard	Protection	Schutz	Protección	
	28	8000 66313	1	Piastrina	Plate	Plaquette	Plättchen	Placa	
	29	8D00 33690	3	Molla	Spring	Ressort	Feder	Resorte	
	30	8000 66298	3	Rivetto	Rivet	Rivet	Niet	Remache	
	31	8000 73834	1	Catadiottro	Reflector	Catadioptrique	Ruckstrahler	Catafaros	
	32	62N1 15502	2	Rondella	Washer	Rondelle	Unterlegscheibe	Arandela plana	
	33	61N1 15191	2	Dado autobloccante	Nut	Ecrou	Mutter	Tuerca	
	34	8000 62733	2	Vite	Screw	Vis	Schraube	Tornillo	
	35	8000 44240	2	Dado	Nut	Ecrou	Mutter	Tuerca	
	35	61N1 15192	2	Dado (CH-A-D)	Nut (CH-A-D)	Ecrou (CH-A-D)	Mutter (CH-A-D)	Tuerca (CH-A-D)	
E	35	8000 40718	2	Dado	Nut	Ecrou	Mutter	Tuerca	
	36	8000 22271	2	Rondella	Washer	Rondelle	Scheibe	Arandela plana	
	36	62N1 15548	2	Rondella (CH-A-D)	Washer (CH-A-D)	Rondelle (CH-A-D)	Scheibe (CH-A-D)	Arandela plana (CH-A-D)	
E	36	62N1 15503	2	Rondella	Washer	Rondelle	Scheibe	Arandela plana	
E	37	8000 62726	2	Vite	Screw	Vis	Schraube	Tornillo	
	38	8000 61313	4	Dado	Nut	Ecrou	Mutter	Tuerca	
	39	8000 87001	2	Piastrina	Plate	Plaquette	Plättchen	Placa	
	40	8000 35049	2	Gommino	Rubber pad	Pièce caoutchouch	Gummstück	Goma	
	41	8000 62416	2	Distanziale	Spacer	Entretoise	Distanzstück	Separador	
	42	8000 18048	2	Antivibrante	Silent block	Antivibration	Schwingungsdämpfer	Anti vibrador	
	43	8000 21535	2	Rondella	Washer	Rondelle	Scheibe	Arandela plana	
	44	8000 61313	2	Dado	Nut	Ecrou	Mutter	Tuerca	
	45	8000 62728	4	Vite	Screw	Vis	Schraube	Tornillo	
	46	8AA0 45495	2	Bussola	Bushing	Douille	Büchse	Manguito	
	47	8000 85751	2	Rosetta carenata	Washer	Rondelle	Scheibe	Arandela plana	
	48	7715 6672B	2	Vite	Screw	Vis	Schraube	Tornillo	
	49	8000 44240	2	Dado	Nut	Ecrou	Mutter	Tuerca	

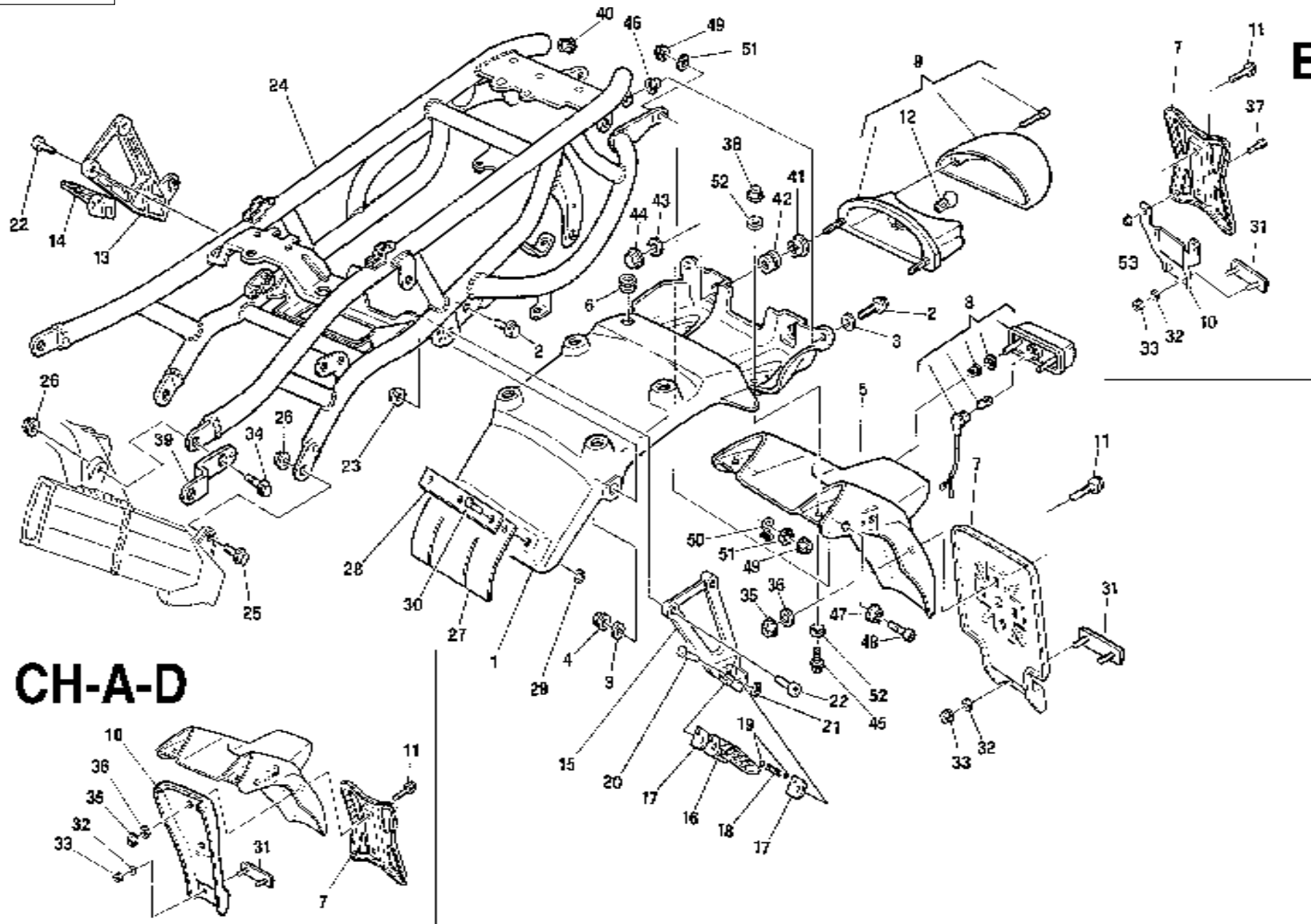

CH-A-D

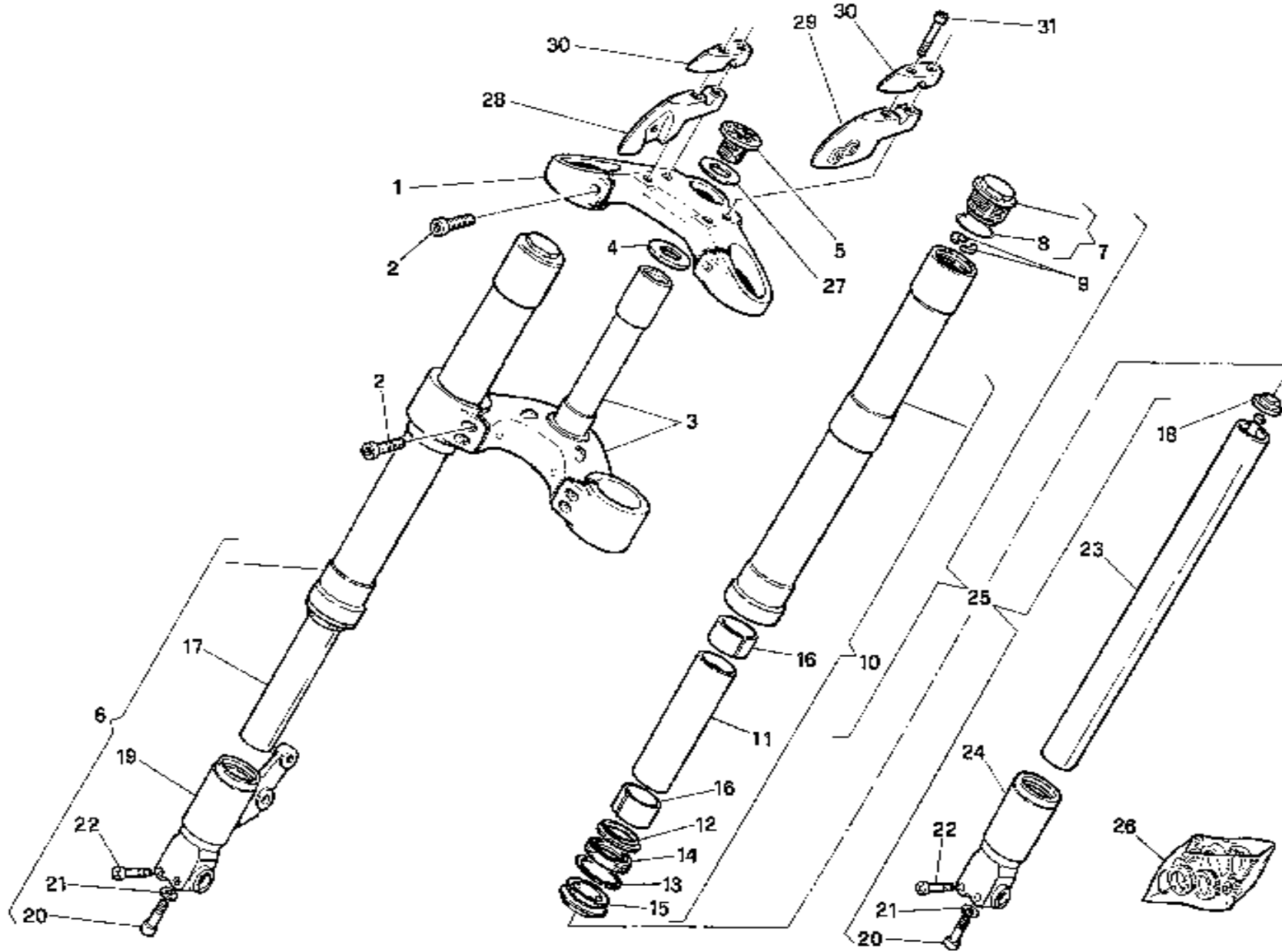

Note Notes Notas	Pos. No. N. Index Pos.	N° Codice Code No. Nr. Code Code Nr N. Cod.	Q.tà Q.ty Q.te M.ge C.ad	DENOMINAZIONE	NAME	DESIGNATION	BESHREIBUNG	DENOMINACION	Validità Validity Validité Gültig Valides
	1	80A0 85763	1	Testa di sterzo	Steering head	Tête direction	Lenkkopf	Cabezal de dirección	
	2	77157252B	6	Vite	Screw	Vis	Schraube	Tornillo	
	3	8000 85842	1	Base sterzo- perno	Steering crown	Socle de direction	Gabelbrücke	Base de dirección	
	4	8000 70182	1	Calotta	Cover	Couvercle	Haube	Casquete	
	5	8000 85449	1	Vite	Screw	Vis	Schraube	Tornillo	
	6	8000 85764	1	Gamba Dx. compl.	R.H. fork leg assy	Fourche complete D.	Telegabel Kpl. R.	Horquilla derech. compl.	
	7		2	Tappo compl.	Plug	Bouchon	Stopfen	Tapòn	
G	8		2	Anello OR	O-Ring	Bague OR	O-Ring	Anillo OR	
	9		4	Semirondella	Split washer	Demi-rondelle	Halbscheibe	Semiarandela	
	10		2	Portastelo compl.	Comp. stem holder	Porte-tige compl.	Kpl. Schafthalter	Portavastago	
	11		2	Tubetto	Pipe	Tuyau	Rohr	Tubo	
	12		2	Scodellino	Cup	Cuvette	Teller	Cubeta	
	13		2	Anello elastico	Seal ring	Bague d'étanchéité	Dichtungsring	Anillo elástico	
G	14		2	Anello di tenuta	Seal ring	Bague d'étanchéité	Dichtungsring	Anillo de retención	
G	15		2	Raschiapolvere	Dust scraper	Racloir poudre	Pulverabschaber	Rascador de polvo	
	16		4	Boccola	Bush	Douille	Buchse	Casquillo	
	17		1	Assieme tubo portante destro completo	R Pumping element	Element de pompage D	Pumpenelement R	Bombeadora compl. D	
	18		2	Anello portamolla	Ring	Bague	Ring	Anillo	
	19		1	Fondello Dx. compl.	Right bottom compl.	Fond droit compl.	Rechte Bodenscheibe Kpl.	Casquillo derecho compl.	
	20		2	Vite	Screw	Gauche	Schraube	Tornillo	
	21		2	Rosetta	Washer	Rondelle	Scheibe	Arandela	
	22		4	Vite	Screw	Vis	Schraube	Tornillo	
	23		1	Assieme tubo portante sinistro completo	L Pumping element	Element de pompage G	Pumpenelement L	Bombeadora compl. I	
	24		1	Fondello Sx. compl.	Left bottom compl	Fond gauche compl.	Linke BodenscheibeKpl.	Casquillo izquierdo compl.	
	25	8000 85765	1	Gamba Sx. com.	Compl. L.H. leg	Jambe G. compl.	Kpl. L. Bein	Pata izq. compl.	
	26	8000 79008	1	Gruppo guarnizioni	Gasket set	Grupe garniture	Dichtungssatz	Grupo juntas	
	27	8000 15397	1	Rosetta piana	Washer	Rondelle	Scheibe	Arandela	
	28	80A0 85760	1	Cavallotto inf. Dx	U-Bolt lower R.	Cavalier inférieur D.	Unten Bügebolzen R.	Caballate inferior Der.	
	29	80A0 85761	1	Cavallotto inf. Sx	U-Bolt lower L.	Cavalier inférieur G.	Unten Bügebolzen L.	Caballate inferior iz.	
	30	80A0 85841	2	Cavallotto	U-Bolt	Cavalier	Bügebolzen	Caballate	

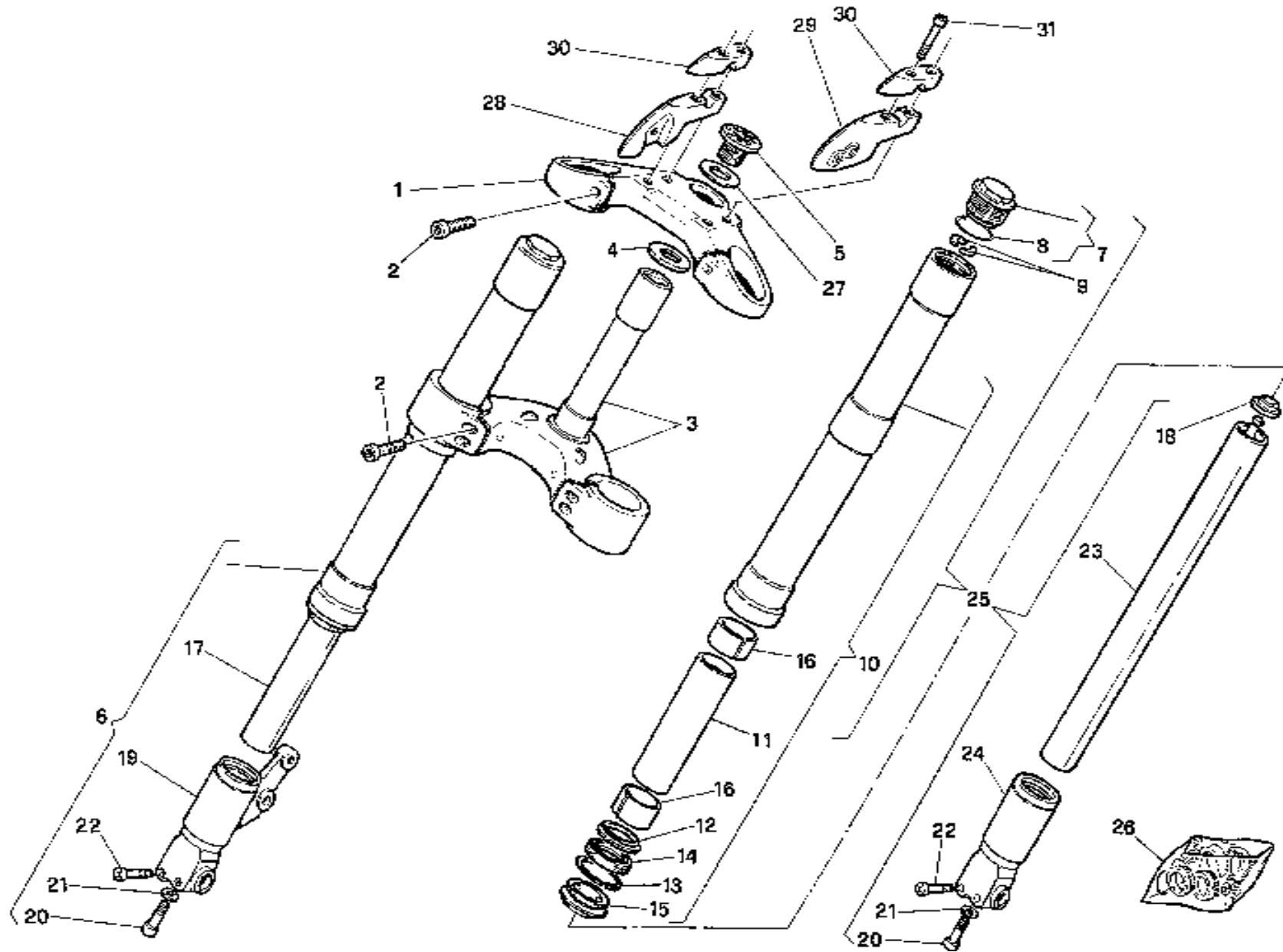

Note Notes Notes Marke Notas	Pos. No. N. Index Pos.	N° Codice Code No. Nr. Code Code Nr N. Cod.	Q.tà Q.ty Q.té M.ge C.ad	DENOMINAZIONE	NAME	DESIGNATION	BESHREIBUNG	DENOMINACION	Validità Validity Validité Gültig Valides
G	31	60N1 02563	4	Vite Per i ricambi sono forniti anche in gruppo pos. 26	Screw Gasket are also supplied in Bag Ref. N° 26	Vis Piecés de rechange son fournies en unités pos. 26	Schraube Die Dichtungen sind auch im Umschlag Bez. Nr 26	Tornillo Partes de recambio es provisto en grupo pos. 26	

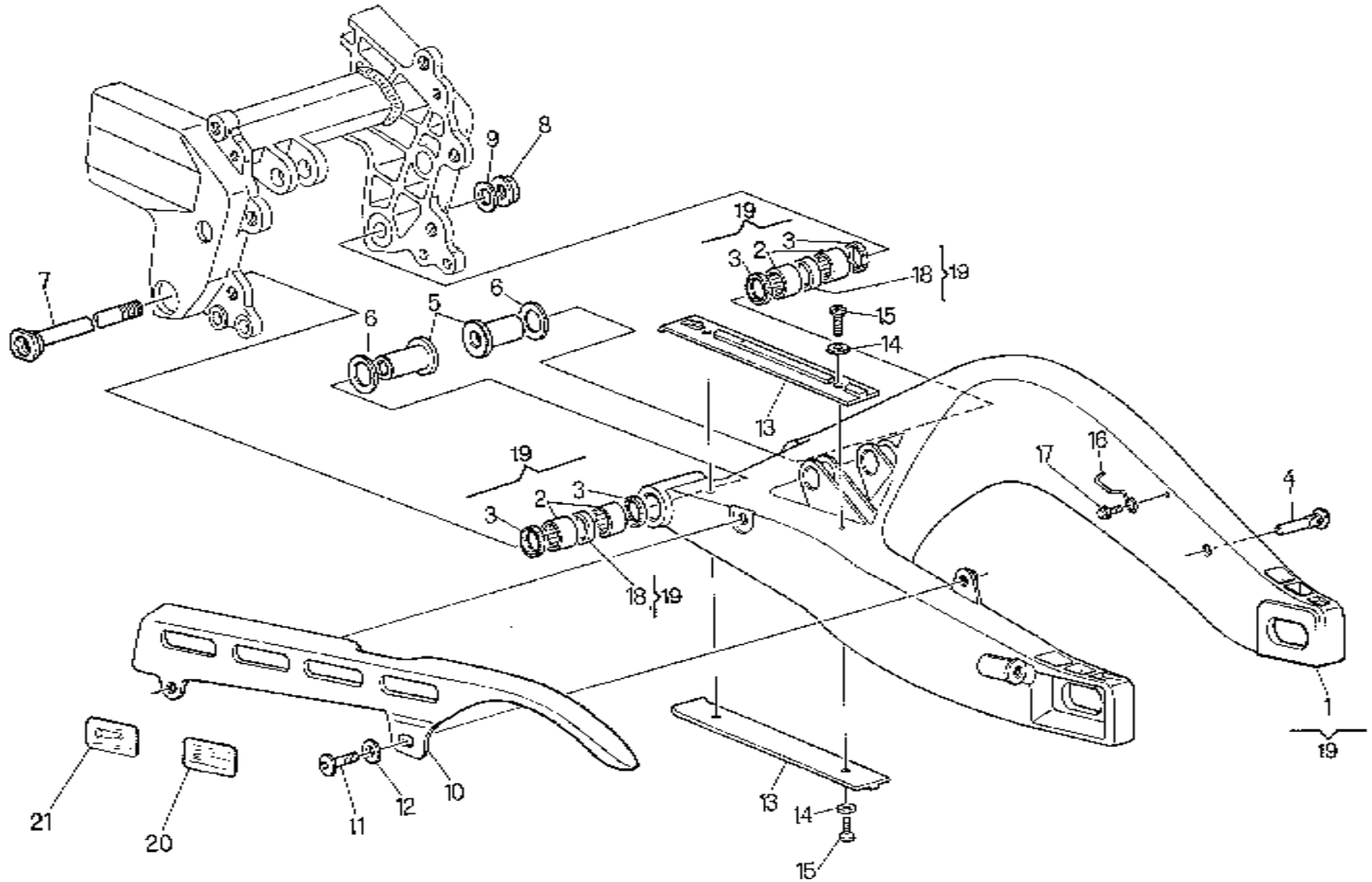

Note Notes Notas	Pos. No. N. Index Pos.	N° Codice Code No. Nr. Code Code Nr N. Cod.	Q.tà Q.ty Q.te M.ge C.ad	DENOMINAZIONE	NAME	DESIGNATION	BESHREIBUNG	DENOMINACION	Validità Validity Validité Gültig Valides
	1	80C0 62650	1	Forcellone (8D67)	Fork (8D67)	Fourche (8D67)	Gabel (8D67)	Horquilla (8D67)	
	2	8000 32064	4	Cuscinetto a rullini	Needle bearing	Roulement à aiguilles	Nadelkäfig	Cojinete	
	3	8000 32065	4	Anello di tenuta	Seal ring	Bague d'étanchéité	Dichtungsring	Anillo de retención	
	4	8000 62669	1	Perno piastra portapinzza	Pin	Pivot	Bolzen	Perno	
	5	8000 66188	2	Bussola	Bushing	Douille	Büchse	Manguito	
	6	8B00 32069	2	Rosetta Sp. 0,5	Washer	Rondelle	Scheibe	Arandela	
	6	8D00 32069	2	Rosetta Sp. 0,8	Washer	Rondelle	Scheibe	Arandela	
	6	8E00 32069	2	Rosetta Sp. 1	Washer	Rondelle	Scheibe	Arandela	
	6	8F00 32069	2	Rosetta Sp. 1,2	Washer	Rondelle	Scheibe	Arandela	
	7	8000 62637	1	Perno	Pin	Pivot	Bolzen	Perno	
	8	8000 62638	1	Dado	Nut	Ecrou	Mutter	Tuerca	
	9	8000 62639	1	Rondella piana	Washer	Rondelle	Unterlegscheibe	Arandela plana	
	10	8000 88306	1	Paracatena	Chain guard	Carter	Kettenkasten	Paracadena	
	11	80B0 55703	2	Vite	Screw	Vis	Schraube	Tornillo	
	12	8000 56391	2	Rosetta	Washer	Rondelle	Scheibe	Arandela	
	13	8000 62622	2	Pattino catena	Chain slider	Glissière	Gleitbahn	Plato cadena	
	14	8000 62653	4	Distanziale	Spacer	Entretoise	Distanzstück	Separador	
	15	8000 57006	4	Vite	Screw	Vis	Schraube	Tornillo	
	16	8000 62561	1	Gancio	Hook	Crochet	Haken	Gancho	
	17	8000 62725	1	Vite	Screw	Vis	Schraube	Tornillo	
	18	8000 67977	2	Distanziale	Spacer	Entretoise	Distanzstück	Separador	
	19	8000 77795	1	Ass. forcellone comp. (8D67)	Fork assy (8D67)	Fourche ensemble (8D67)	Gabel Kpl (8D67)	Horquilla compl. (8D67)	
	20	8A00 66293	1	Decal reg. pneum.(MICHELIN)	Tyre pressure tr. (MICHELIN)	Décal press. Pneu (MICHELIN)	Reifendruckstreifen (MICHELIN)	Calc.presión neum.(MICHELIN)	
	20	8000 66293	1	Decal reg.pn.(PIRELLI-DUNLOP)	Tyre press.tr.(PIRELLI-DUNLOP)	Décal pr.Pneu (PIRELLI-DUNLOP)	Reifendruckstr (PIRELLI-DUNLOP)	Calc..pr.neum.(PIRELLI-DUNLOP)	
	21	8000 66292	1	Decal regolazione catena	Adjust chain transfer	Décal réglage Châin	Kettenregalungsstreifen	Càlcomania regulaciòn cadena	

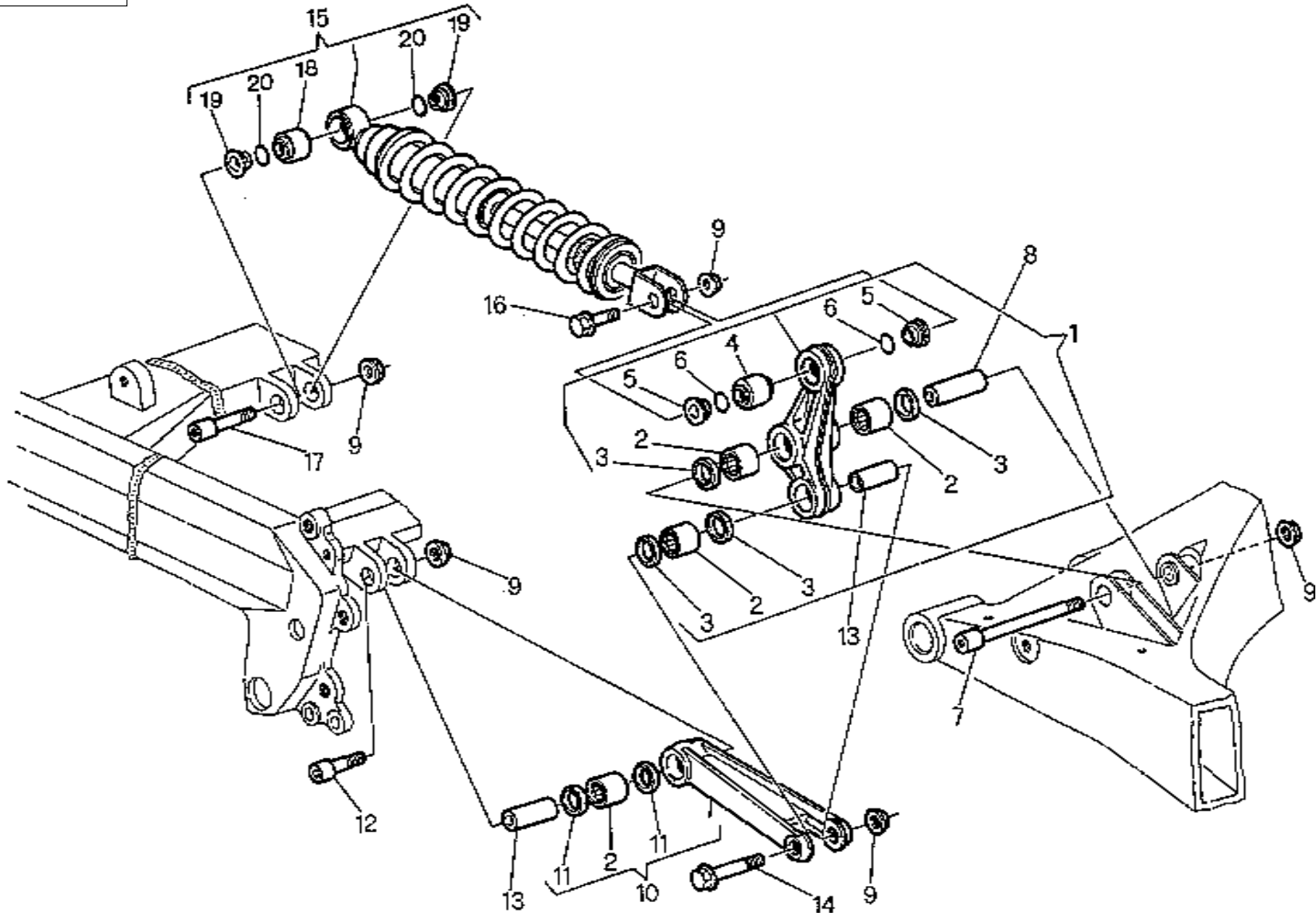

Note Notes Notas	Pos. No. N. Index Pos.	N° Codice Code No. Nr. Code Code Nr. N. Cod.	Q.tà Q.ty Q.te M.ge C.ad	DENOMINAZIONE	NAME	DESIGNATION	BESHREIBUNG	DENOMINACION	Validità Validity Validité Gültig Valides
	1	8000 77030	1	Bilanciere completo	Rocking lever	Balancier	Schwinge	Balancines	
	2	8000 38956	4	Cuscinetto a rullini	Needle bearing	Roulement à aiguilles	Nadelkäfig	Cojinete	
	3	8000 38957	4	Anello di tenuta	Seal ring	Bague d'étanchéité	Dichtungsring	Anillo de retención	
	4	8000 72168	1	Cuscinetto sferico	Bearing	Roulement	Lager	Cojinete	
	5	8000 67165	4	Bussola	Bushing	Douille	Büchse	Manguito	
	6	8000 76785	4	Guarnizione	Gasket	Garnitue	Dichtung	Junta	
	7	8000 62571	1	Vite	Screw	Vis	Schraube	Tornillo	
	8	8000 62574	1	Distanziale	Spacer	Entretoise	Distanzstück	Separador	
	9	8000 42022	4	Dado autobloccante	Nut	Ecrou	Mutter	Tuerca	
	10	8000 66190	1	Biella completa	Connecting rod compl.	Bielle compl.	Pleuelstange kpl.	Biela motor completa	
	11	8000 38957	2	Anello di tenuta	Seal ring	Bague d'étanchéité	Dichtungsring	Anillo de retención	
	12	8000 62570	1	Vite	Screw	Vis	Schraube	Tornillo	
	13	8000 62575	2	Distanziale	Spacer	Entretoise	Distanzstück	Separador	
	14	8000 62572	1	Vite	Screw	Vis	Schraube	Tornillo	
	15	8000 85766	1	Ammortizzatore completo	Shock absorber assy	Ammortisseur compl.	Stossdämpfer kpl.	Amortiguador compl.	
	16	8000 62573	2	Vite	Screw	Vis	Schraube	Tornillo	
	17	8000 62569	1	Vite	Screw	Vis	Schraube	Tornillo	
	18	8000 72168	1	Cuscinetto sferico	Bearing	Roulement	Lager	Cojinete	
	19	8000 72169	2	Bussola	Bushing	Douille	Büchse	Manguito	
	20	8000 34323	2	Guarnizione	Gasket	Garnitue	Dichtung	Junta	

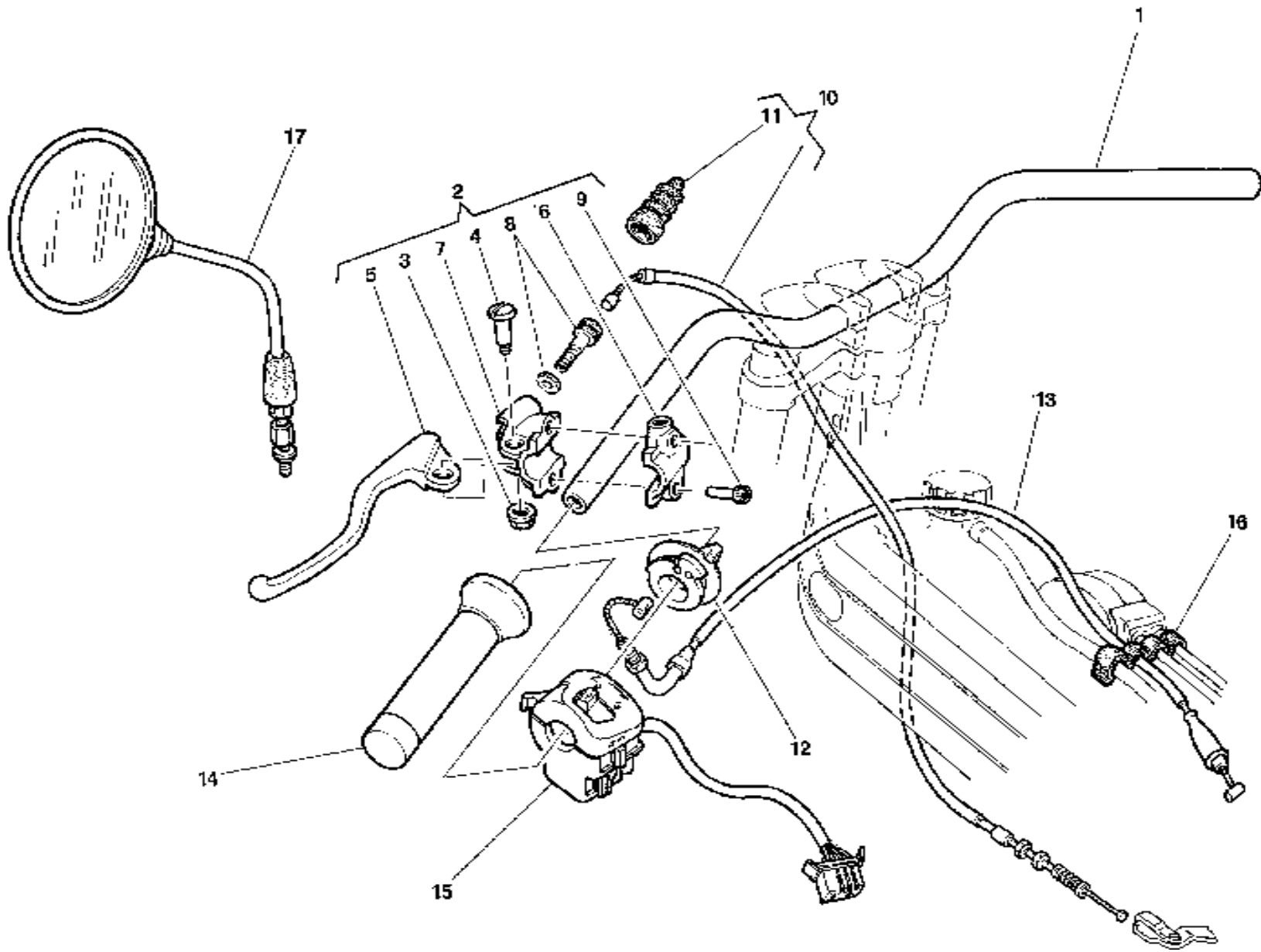

Note Notes Notas	Pos. No. N. Index Pos.	N° Codice Code No. Nr. Code Code Nr N. Cod.	Q.tà Q.ty Q.te M.ge C.ad	DENOMINAZIONE	NAME	DESIGNATION	BESHREIBUNG	DENOMINACION	Validità Validity Validité Gültig Valides
	1	8000 85838	1	Manubrio	Handlebar	Guidon	Lenker	Manillar	
	2	8000 85703	1	Assieme comando frizione	Clutch control and light	Ensemble embrayage	Kupplungseinschaltungs	Juego mando embrague	
	3	8000 14868	2	Dado frenato	Nut	Ecrou	Mutter	Tuerca	
	4	8000 67354	1	Perno	Pin	Pivot	Bolzen	Perno	
	5	8000 69795	1	Leva frizione	Lever	Levier	Hebel	Palanca	
	6	8000 78915	1	Cavallotto	U bolt	Cavalier	Bügelbolzen	Caballate	
	7	8000 67162	1	Supporto	Support	Support	Halterung	Soporte	
	8	8000 67355	1	Registro	Adjustment	Réglage	Regler	Regulación	
	9	7715 6692B	2	Vite	Screw	Vis	Schraube	Tornillo	
	10	8000 85745	1	Assieme trasmissione frizione	Clutch cable assy	Cable comm. embrayage comp.	Kupplungszung kpl	Juego trans. embrague	
	11	8000 48918	1	Gommino	Rubber	Pièce caoutchouch	Gummistück	Goma	
	12	8000 66167	1	Comando starter	Starter	Starter	Startersteuerung	Mando starter	
	13	8000 87567	1	Trasmissione starter	Starter wire	Trasm. starter	Anlassen kabel	Trasm. starter	
	14	8000 85753	1	Manopola Sx	L.H. Grip	Poignée G.	Handgriff L.	Manopla izquierda	
	15	8000 85791	1	Commutatore sinistro completo	Commutator L.	Commutateur G.	Kommutator L.	Commutador izquierdo compl.	
	16	8000 67558	1	Graffetta	Clip	Agrafe	Klemmstück	Clip	
	17	8000 85917	1	Specchietto retrovisore Sx	L.H. driving mirror	Rétroviseur G.	L. Rückspiegel	Espejo retrovisor izquierdo	

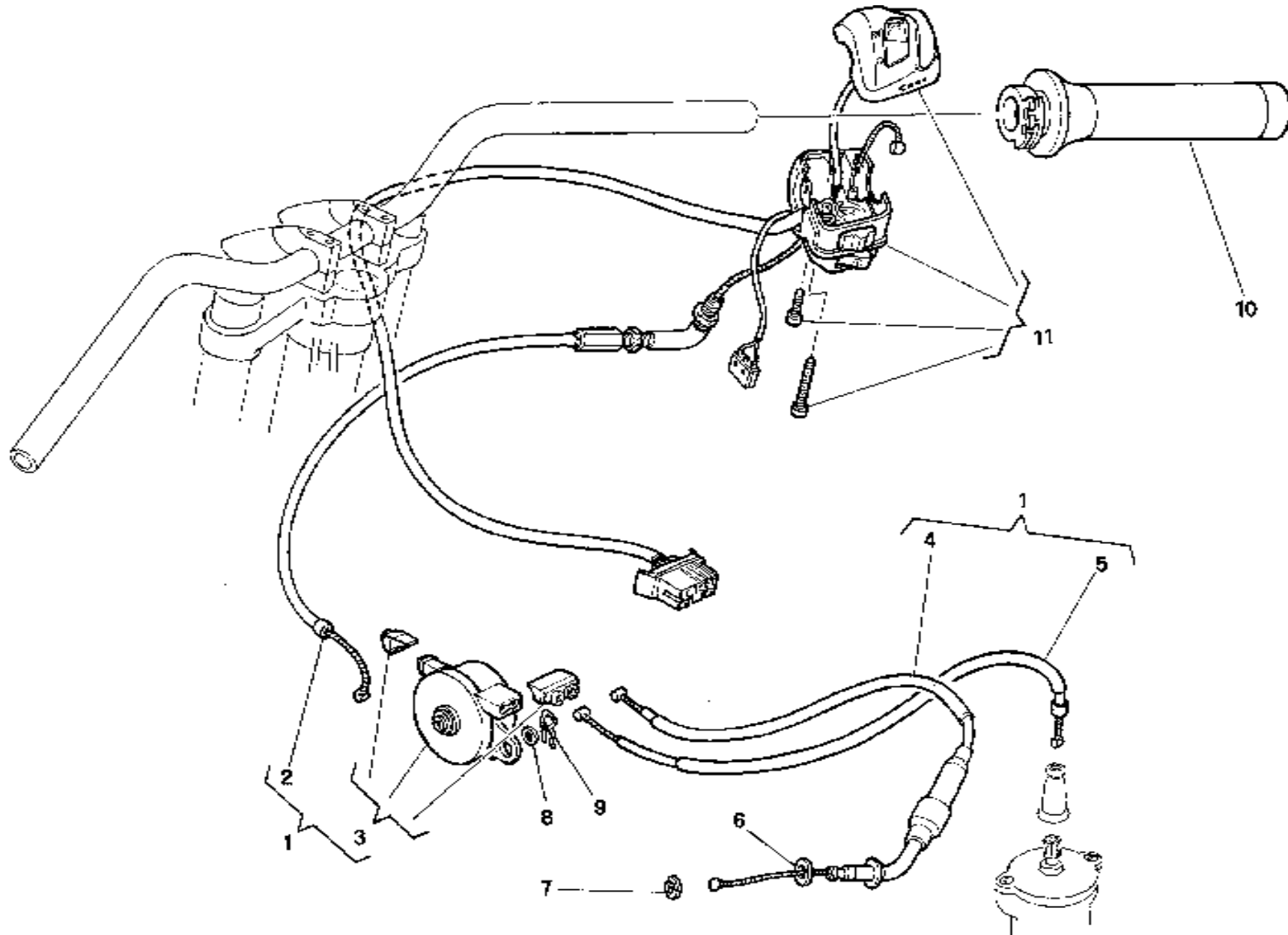

Note Notes Notas	Pos. No. N. Index Pos.	N° Codice Code No. Nr. Code Code Nr. N. Cod.	Q.ità Q.ite M.ge C.äd	DENOMINAZIONE	NAME	DESIGNATION	BESHREIBUNG	DENOMINACION	Validità Validity Validité Gültig Valides
	1	8000 87569	1	Ass. trasmis. comando gas	Throttle transmission	Transm.comm.gaz	Führunggassteuerung	Transm.mando acelerador compl.	
	2	8000 85749	1	Trasmis. comando gas e pompa	Throttle and oil pump wire	Fil comm.gaz et pompe huile	Gassteuerung und Ölpumpen Kabel	Transm.mando acelerador y bomba aceite	
	3	8000 71092	1	Astuccio sdoppiatore	Caables cage	Etui fils	Kabeltasche	Estuche	
	4	8000 87171	1	Trasmis. comando pompa olio	Throttle wire	Fil comm. gaz	Gaszugkabel	Transmis. mando bomba aceite	
	5	8000 87564	1	Trasmis. comando carburatore	Throttle wire	Fil comm. gaz	Gaszugkabel	Trasmisión mando carburador	
	6	8000 09721	1	Rosetta	Washer	Rondelle	Scheibe	Arandela	
	7	66N1 21309	2	Anello elastico	Split ring	Anneau ressort	Drahtspengring	Anillo elastico	
	8	8000 67953	2	Rosetta	Washer	Rondelle	Scheibe	Arandela	
	9	8000 62705	1	Copiglia	Split pin	Coupille	Splint	Clavija	
	10	8000 86389	1	Tubo com. gas con manopola	Gas pipe with grip	Tuyau gaz avec poignée	Gasrohr mit griff	Tubo gas con manopola	
	11	8000 85792	1	Commutatore destro	R. commutator	Commutateur D.	Kommutor R.	Commutador D.	

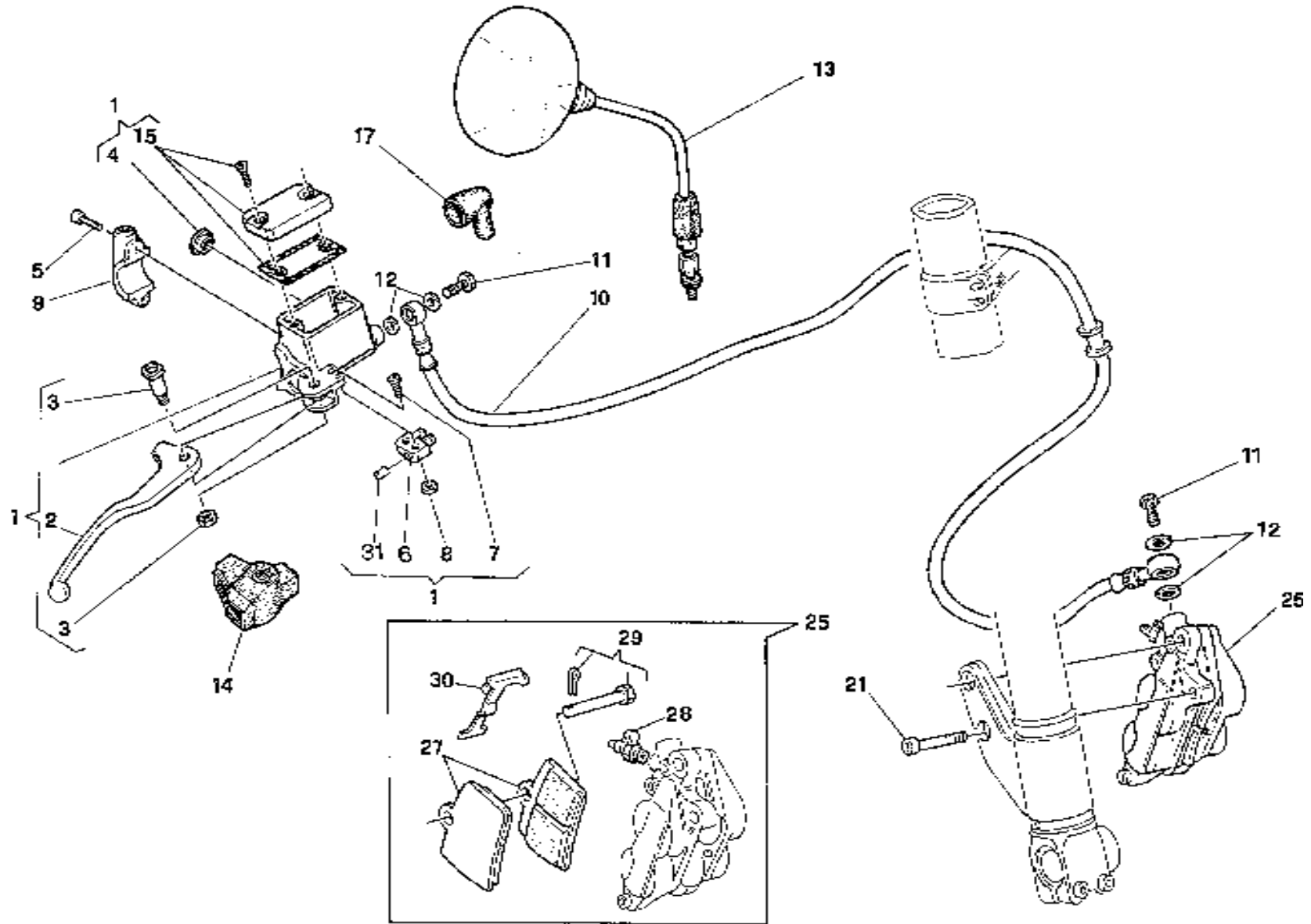

Note Notes Notas	Pos. No. N. Index Pos.	N° Codice Code No. Nr. Code Code Nr N. Cod.	Q.tà Q.ty Q.te M.ge C.ad	DENOMINAZIONE	NAME	DESIGNATION	BESHREIBUNG	DENOMINACION	Validità Validity Validité Gültig Valides
	1	8000 85757	1	Assieme pompa	Pump assy	Pompe compl.	Bremspumpe	Bomba compl.	
	2	80A0 69050	1	Leva	Lever	Levier	Hebel	Palanca	
	3	8000 46664	1	Gruppo revisione perno leva	Lever pin set	Kit revision pivot levier	Hebelbolzensatz	Grupo revis. perno palanca	
	4	8000 49654	1	Oblò	Inspection plug	Capuchon de inspection	Stopfen	Portilla	
	5	7715 6692B	2	Vite	Screw	Vis	Schraube	Tornillo	
	6	8000 47953	1	Interruttore stop	Stop switch	Interrupteur stop	Stopschalter	Interruptor stop	
	7	60N1 07701	2	Vite	Screw	Vis	Schraube	Tornillo	
	8	61N1 15001	2	Dado	Nut	Ecrou	Mutter	Tuerca	
	9	8000 67164	1	Cavallotto	U bolt	Cavalier	Bügelbolzen	Caballate	
	10	8000 85746	1	Tube mandata	Pipe	Tuyau	Rohr	Tube	
	11	8000 57155	2	Vite	Screw	Vis	Schraube	Tornillo	
	12	8000 21480	4	Rosetta	Washer	Rondelle	Scheibe	Arandela	
	13	8000 85716	1	Specchietto retrovisore Dx	R.H. driving mirror	Rétroviseur D.	R. Rückspiegel	Espejo retrovisor derecho	
	14	8000 70377	1	Cappuccio	Cap	Capuchon	Gummikappe	Capuchòn	
	15	8000 46665	1	Gruppo Tappo	Cork unit	Groupe bouchon	Stopfeneinheit	Grupo tapón	
	17	8000 25989	1	Cappuccio	Cap	Capuchon	Gummikappe	Capuchòn	
	21	7715 7542B	1	Vite fiss. pinza	Screw	Vis	Schraube	Tornillo	
	25	8000 78379	1	Pinza completa di pastiglie	Caliper	Etrier	Sattel	Pinza	
E	25	8000 77781	1	Pinza completa di pastiglie	Caliper	Etrier	Sattel	Pinza	
	27	8000 78331	1	Coppia pastiglie	Pads pair	Paire plaquettes	Bremsbelagpaar	Pareja pastillas	
	28	8000 60404	1	Gruppo revisione spurgo	Bleeding set	Kit de rev. curage	Reinigungsatz	Grupo revis. purga	
	29	8000 80301	1	Ass. gruppo rev. perno	Plug overhaul device assy	Ensemble groupe revision axe	Übersicht bolzenrevisionsgruppe	Conjunto grupo revision perno	
	30	8000 77782	1	Molla	Spring	Ressort	Feder	Resorte	
	31	8000 57772	1	Nottolino	Pawl	Cliquet	Klinke	Pestillo	

PLANET 125

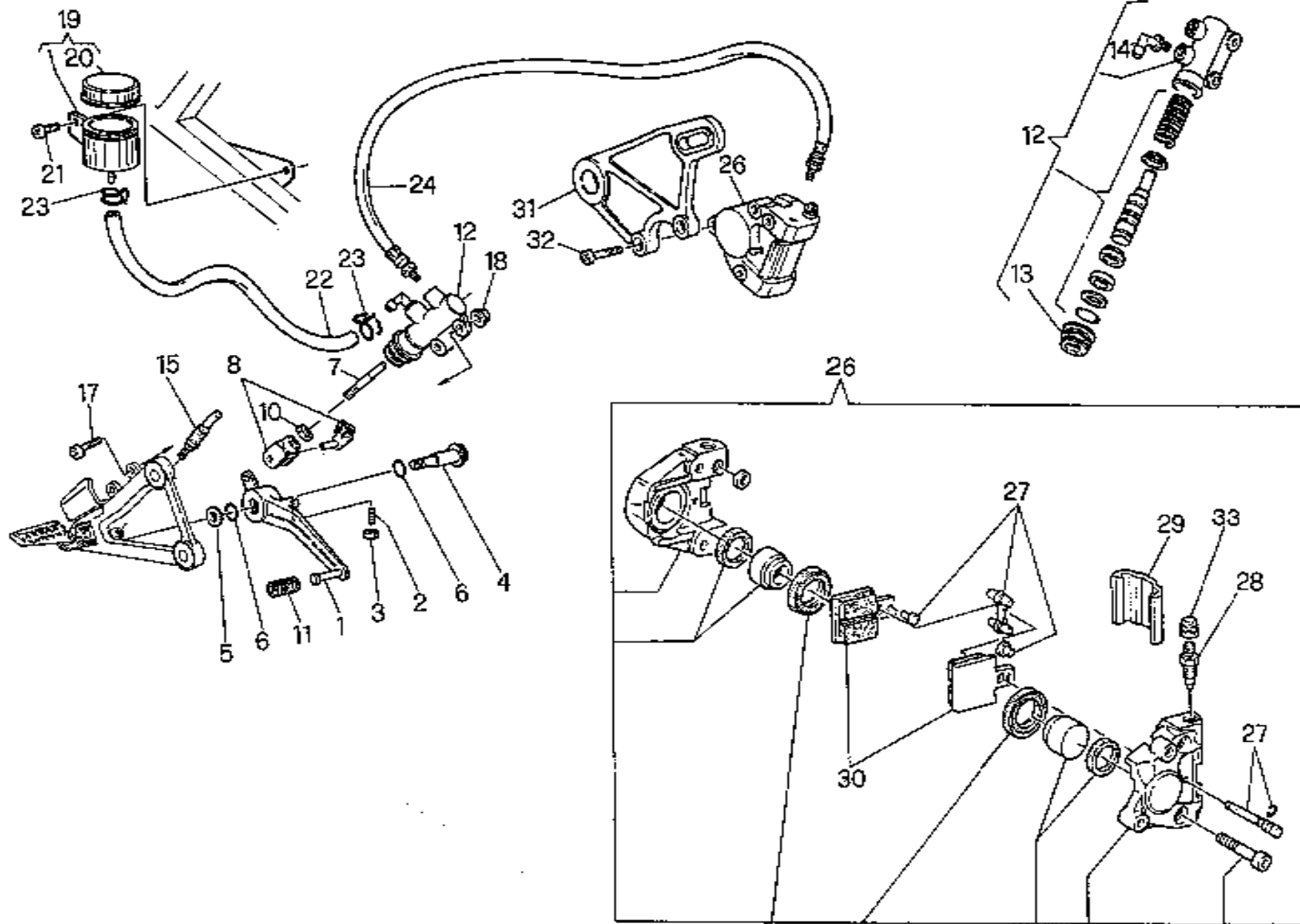

Note Notes Notas	Pos. No. N. Index	N° Codice Code No. Nr. Code Code Nr N. Cod.	Q.tà Q.ty Q.te M.ge C.ad	DENOMINAZIONE	NAME	DESIGNATION	BESHREIBUNG	DENOMINACION	Validità Validity Validité Gültig Valides
	1	8000 66177	1	Pedale freno	Pedal	Pedale	Pedal	Pedal	
	2	8000 67981	1	Grano	Dowel	Grain	Stift	Pasador	
	3	61N1 15062	1	Dado	Nut	Ecrou	Mutter	Tuerca	
	4	80A0 53548	1	Perno	Pin	Pivot	Bolzen	Perno	
	5	8000 59485	1	Rondella	Washer	Rondelle	Scheibe	Arandela	
	6	8000 01199	2	Anello	Ring	Bague	Ring	Anillo	
	7	8A00 62586	1	Asta rinvio	Transmission rod	Barre de renvoi	Vorgelegestab	Varilla transmisión	
	8	80A0 55757	1	Forcella	Fork	Fourche	Gabel	Horquilla	
	9	80A0 64617	1	Clip per forcella	Fork clip	Fourche ressort	Federgabel	Resorte	
	10	61N1 15062	1	Dado	Nut	Ecrou	Mutter	Tuerca	
	11	8000 62636	1	Manicotto	Sleeve	Manchon	Muffe	Manguito	
	12	8000 55991	1	Assieme pompa freno	Brake pump assy	Pompe frein	Bremspumpe	Bomba freno	
	13	8000 57758	1	Cuffia parapolvere	Dust cover	Pare poussière	Staubdeckel	Tapa retención polvo	
	14	8000 57757	1	Gruppo revisore raccordo	Connection set	Kit revision raccord	Anschluss repar. Satz	Grupo revis. empalme	
	15	5394 0031B	1	Interruttore stop	Stop switch	Interrupteur stop	Stopschalter	Interruptor stop	
	17	7715 6692B	2	Vite	Screw	Vis	Schraube	Tornillo	
	18	8000 44240	2	Dado autobloccante	Nut	Ecrou	Mutter	Tuerca	
	19	8000 66529	1	Serbatoio	Tank assy	Réservoir	Tank	Depósito	
	20	8000 66305	1	Tappo	Plug	Bouchon	Verschluss	Tapón	
	21	8000 62725	1	Vite	Screw	Vis	Schraube	Tornillo	
	22	8A00 66179	1	Tubo	Pipe	Tuyau	Rohr	Tubo	
	23	7411 0151A	2	Fascetta	Clamp	Collier	Schelle	Banda	
	24	8000 66180	1	Tubo	Pipe	Tuyau	Rohr	Tubo	
	26	8000 66304	1	Ass. pinza completa di pastiglie	Caliper assy	Pince de frein, compl.	Bremszange, Kpl.	Pinza compl.	
	27	8000 66503	1	Gruppo revisione perni	Lever pin set	Kit revision pivot levier	Hebelbolzensatz	Grupo revis. perno palanca	
	28	8000 39727	1	Gruppo revisione spurgo	Bleeding set	Kit de rev. curage	Reinigungsatz	Grupo revis. purga	
	29	8000 39726	1	Coperchietto	Cover	Couvercle	Deckel	Tapa	
	30	8000 46147	1	Coppia pastiglie	Pads pair	Paire plaquettes	Bremsbelagpaar	Pareja pastillas	
	31	80A0 60697	1	Piastra porta pinza	Plate	Plaque	Platte	Placa	
	32	60N1 07351	2	Vite	Screw	Vis	Schraube	Tornillo	
	33	8000 48432	2	Parapolvere	Boot	Pare poussière	Staubdeckel	Parapolveres	

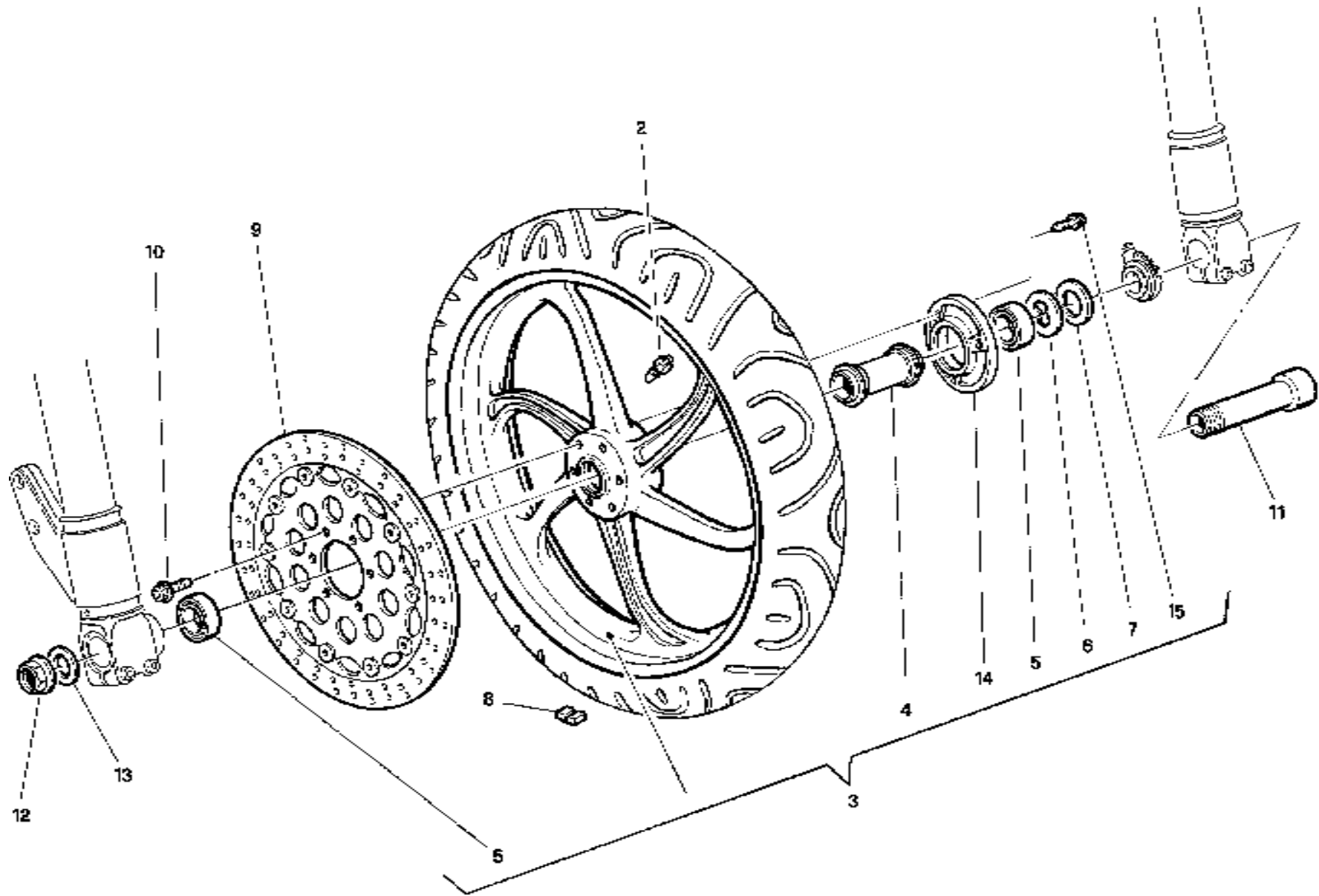

Note Notes Notas	Pos. No. N. Mark Index Pos.	N° Codice Code No. Nr. Code Code Nr N. Cod.	Q.tà Q.ty Q.te M.ge C.äd	DENOMINAZIONE	NAME	DESIGNATION	BESHREIBUNG	DENOMINACION	Validità Validity Validité Gültig Valides
	2	8000 43384	1	Valvola	Valve	Soupape	Ventil	Válvula	
	3	8000 82097	1	Cerchio ruota completo	Wheel rim assy	Jante roue com.	Radfelge kpl.	Llanta rueda com.	
	4	8000 85907	1	Distanziale interno	Spacer	Entretoise	Distanzstück	Separador	
	5	8000 72228	2	Cuscinetto	Bearing	Roulement	Kugellager	Cojinete	
	6	8000 62648	1	Trascinatore rinvio	Driving entrainer	Entraîneur	Mitnehmer	Arrastrador	
	7	8000 64471	1	Anello di tenuta	Seal ring	Bague d'étanchéité	Dichtungsring	Anillo de retención	
	8	8000 42040	1	Placchetta	Balance	Masse	Platte	Placa	
	9	8000 62587	1	Disco freno	Brake disc	Disque frein	Bremsscheibe	Disco freno	
	10	7715 7232B	6	Vite	Screw	Vis	Schraube	Tornillo	
	11	8000 70167	1	Perno	Pin	Pivot	Bolzen	Perno	
	12	8000 70115	1	Dado	Nut	Ecrou	Mutter	Tuerca	
	13	8000 70119	1	Rosetta	Washer	Rondelle	Scheibe	Arandela	
	14	8000 82082	1	Flangia	Flange	Bride	Flansch	Brida	
	15	7715 7232B	3	Vite	Screw	Vis	Schraube	Tornillo	

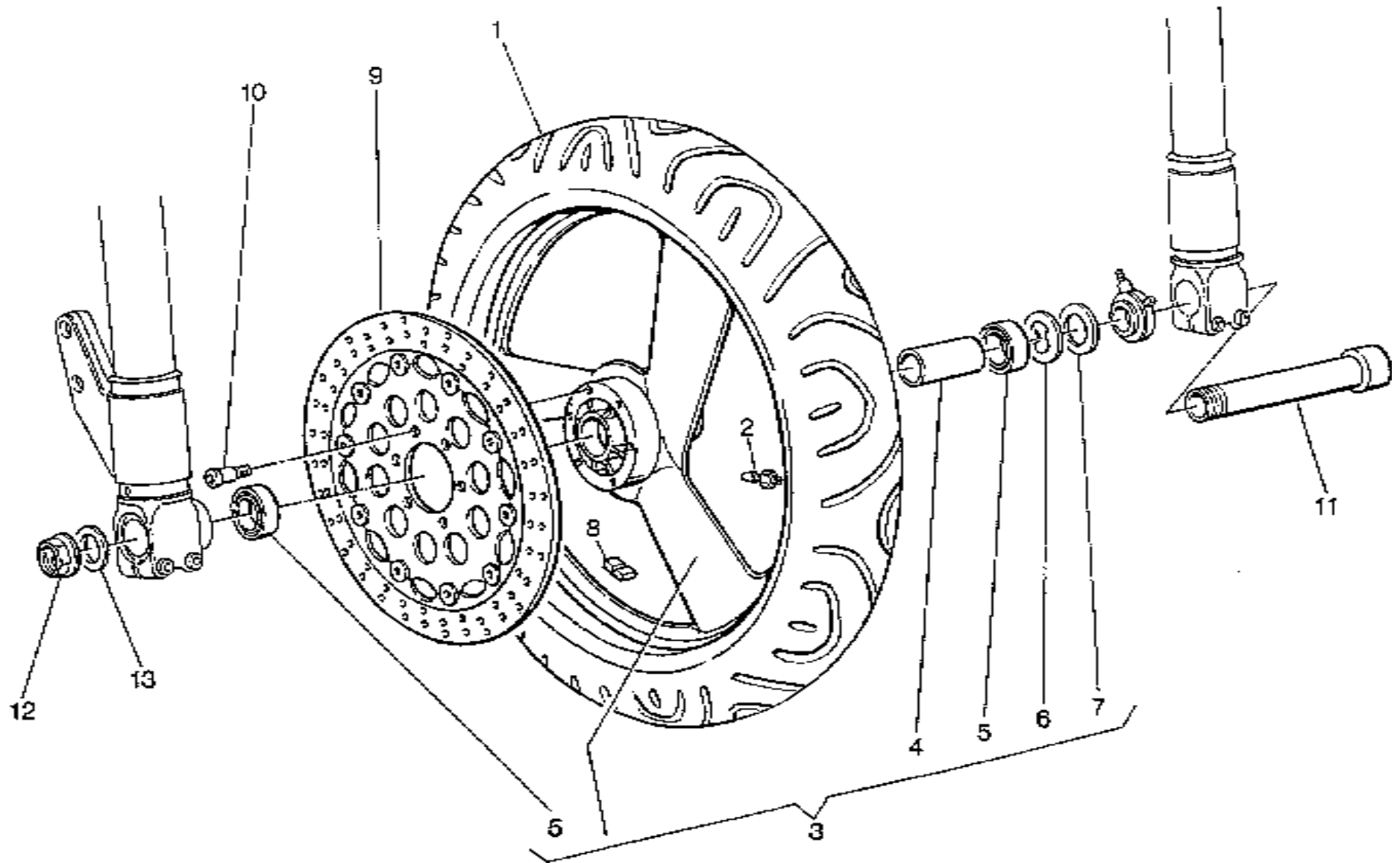

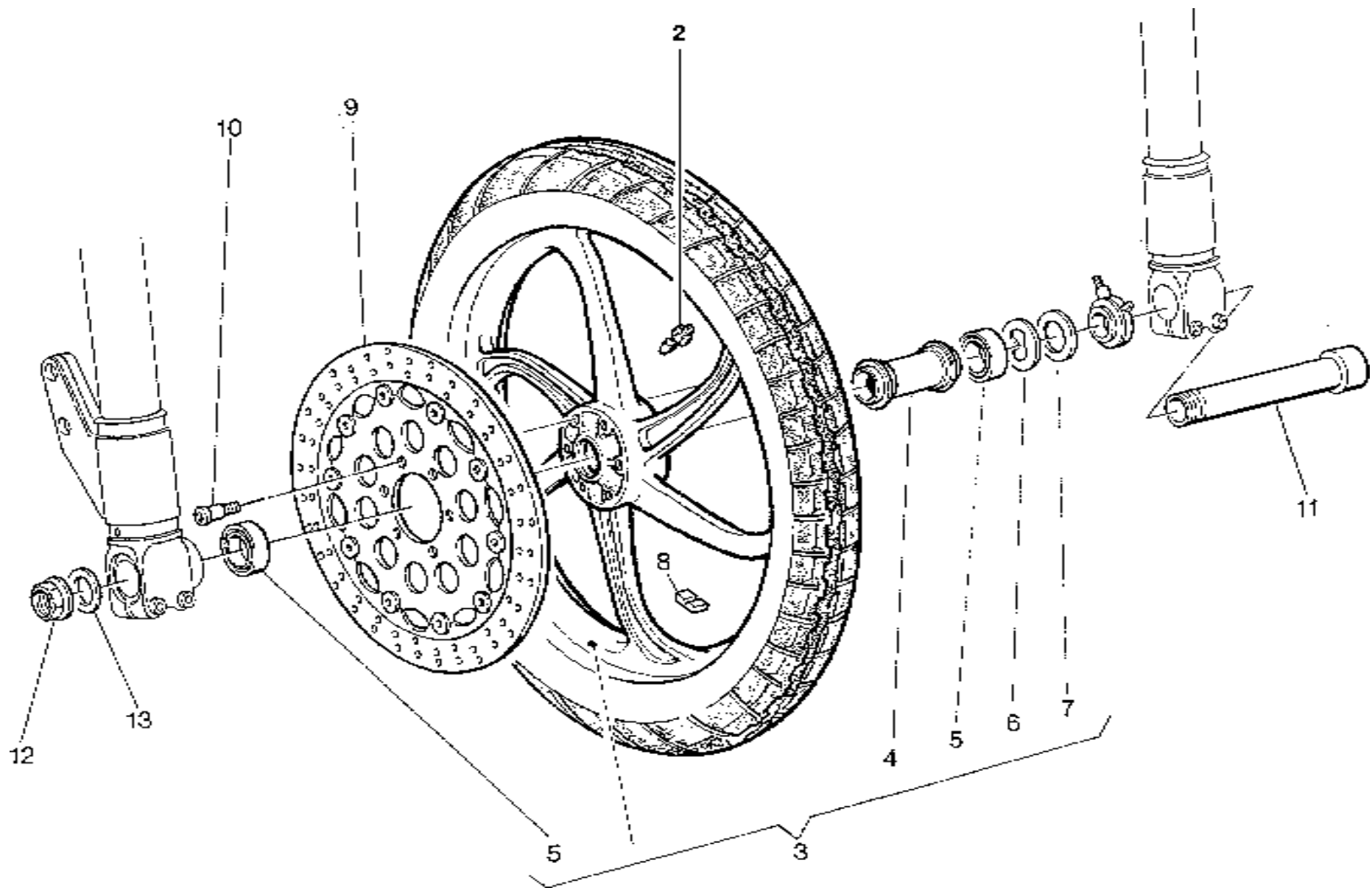

Note Notes Notas	Pos. No. N. Index Pos.	N° Codice Code No. Nr. Code Code Nr N. Cod.	Q.tà Q.ty Q.te M.ge C.àd	DENOMINAZIONE	NAME	DESIGNATION	BESHREIBUNG	DENOMINACION	Validità Validity Validité Gültig Valides
	2	8000 91796	1	Valvola	Valve	Soupape	Ventil	Válvula	
	3	8000 90835	1	Cerchio ruota anteriore (cod. colore A B C E F G)	Front rim (Colour cod. A B C E F G)	Jante avant (cod. couleur A B C E F G)	Felge (Cod. Farbe A B C E F G)	Llanta rueda delantera (còd. colòr A B C E F G)	
	3	8A00 90835	1	Cerchio ruota anteriore (cod. colore H L)	Front rim (Colour cod. H L)	Jante avant (cod. couleur H L)	Felge (Cod. Farbe H L)	Llanta rueda delantera (còd. colòr H L)	
	4	8000 85907	1	Distanziale	Spacer	Entretoise	Distanzstück	Separador	
	5	8000 72228	2	Cuscinetto	Bearing	Roulement	Lager	Cojinete	
	6	8000 62648	1	Trascinatore per rinvio	Driving entrainer	Entraineur	Mitnehmer	Arrastrador	
	7	8000 64471	1	Anello di tenuta	Seal ring	Bague d'étanchéité	Dichtungsring	Anillo de retención	
	8	8000 42040	1	Placchetta bilanciatura	Balance wheight	Masse additive	Gewichtsausgleich	Placa equilibrio	
	9	8000 62587	1	Disco freno anteriore	Front brake disc	Disque frein	Bremsscheibe	Disco freno delantero	
	10	8000 41460	6	Vite	Screw	Vis	Schraube	Tornillo	
	11	8000 70167	1	Perno ruota anteriore	Front wheel pin	Pivot roue avant	Vorderradbolzen	Perno rueda delantera	
	12	8000 70115	1	Dado	Nut	Ecrou	Mutter	Tuerca	
	13	8000 70119	1	Rosetta	Washer	Rondelle	Scheibe	Arandela	

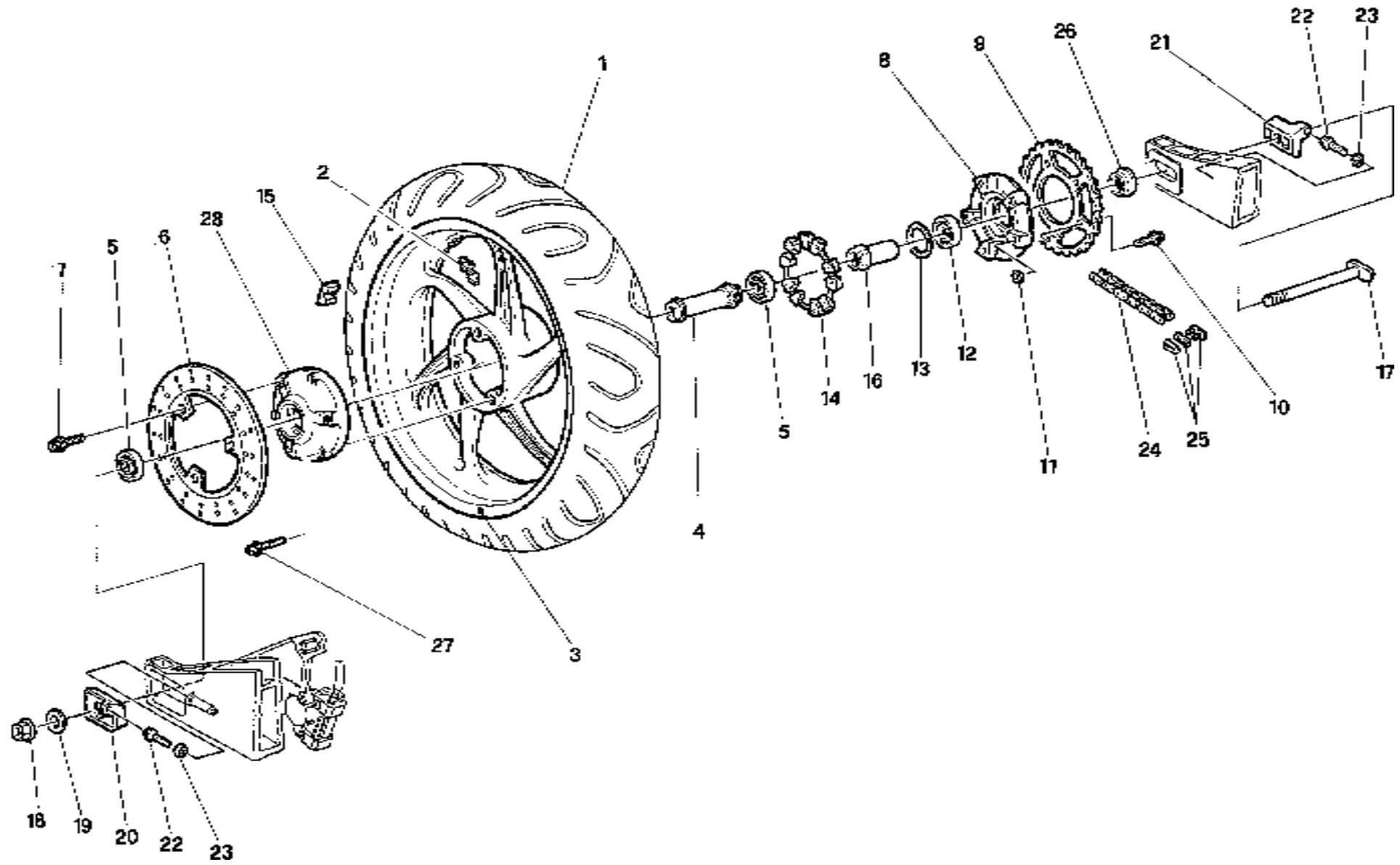

Note Notes Notas	Pos. No. N. Index Pos.	N° Codice Code No. Nr. Code Code Nr. N. Cod.	Q.tà Q.ty Q.te M.ge C.ad	DENOMINAZIONE	NAME	DESIGNATION	BESHREIBUNG	DENOMINACION	Validità Validity Validité Gültig Valides
	2	8000 43384	1	Valvola	Valve	Soupape	Ventil	Válvula	
	3	8000 85808	1	Cerchio ruota com.	Wheel rim assy	Jante roue com.	Radfelge kpl.	Llanta rueda com.	
	4	8000 82078	1	Distanziale interno	Spacer	Entretoise	Distanzstück	Separador	
	5	8000 15659	2	Cuscinetto	Bearing	Roulement	Lager	Cojinete	
	6	8000 82076	1	Disco freno Ø 230	Brake disc	Disque frein	Bremsscheibe	Disco freno	
	7	7715 7232B	6	Vite fissaggio disco	Screw	Vis	Schraube	Tornillo	
	8	80A0 82074	1	Supporto	Support	Support	Halterung	Soporte	
	9	8A00 82077	1	Corona Z = 43	Ring gear	Couronne	Kranz	Corona	
	9	8000 82077	1	Corona Z = 41 (CH-A)	Ring gear Z = 41 (CH-A)	Couronne Z = 41 (CH-A)	Kranz Z = 41 (CH-A)	Corona Z = 41 (CH-A)	
D	9	8A00 82077	1	Corona Z = 43 (CH-A)	Ring gear Z = 43 (CH-A)	Couronne Z = 43 (CH-A)	Kranz Z = 43 (CH-A)	Corona Z = 43 (CH-A)	
	10	7715 7292B	5	Vite	Screw	Vis	Schraube	Tornillo	
	11	8000 56410	5	Dado autobloccante	Nut	Ecrou	Mutter	Tuerca	
	12	8A00 43567	1	Cuscinetto	Bearing	Roulement	Lager	Cojinete	
	13	66N0 21275	1	Anello elastico	Split ring	Anneau ressort	Drahtspengring	Anillo elastico	
	14	8000 88176	1	Parastrappi	Flexible coupling	Pièce caoutchouc	Gummidämpfer	Para tirones	
	15	8000 42040	1	Placchetta bilanciatura	Balance wheight	Masse additive	Gewichtsausgleich	Placa equilibrio	
	16	8000 82114	1	Boccola riduz. cuscinetto	Bush	Douille	Buchse	Manguito	
	17	8000 62612	1	Perno	Pin	Pivot	Bolzen	Perno	
	18	8000 62613	1	Dado	Nut	Ecrou	Mutter	Tuerca	
	19	80A0 19963	1	Rosetta piana	Washer	Rondelle	Scheibe	Arandela	
	20	80A0 60689	1	Tendicatena destra	Chain adjuster	Tendeur de chaine	Kettenspanner	Tensor de cadena	
	21	80A0 60690	1	Tendicatena sinistra	Chain adjuster	Tendeur de chaine	Kettenspanner	Tensor de cadena	
	22	8000 62576	2	Vite	Screw	Vis	Schraube	Tornillo	
	23	80A0 67502	1	Dado	Nut	Ecrou	Mutter	Tuerca	
A	24	8E00 60831	1	Catena regina	Chain	Chaîne	Kette	Cadena	
A	24	8A00 79938	1	Catena takasago	Chain	Chaîne	Kette	Cadena	
	25	8000 47456	1	Giunto regina	Coupling	Joint	Kupplung	Junta	
	25	8000 79939	1	Giunto takasago	Coupling	Joint	Kupplung	Junta	
	26	8000 82113	1	Distanziale esterno	Outside spacer	Entretoise ext.	Distanzstück	Separador	
	27	7715 7252B	3	Vite	Screw	Vis	Schraube	Tornillo	
A				In alternativa	In alternative	En alternative	Die Auswahl	En alternativa	
D				In dotazione (Kit 8000 87696)	To issue (Kit 8000 87696)	En necessaire (Kit 8000 87696)	Ausrüstungsteile (Kit 8000 87696)	En dotación (Kit 8000 87696)	

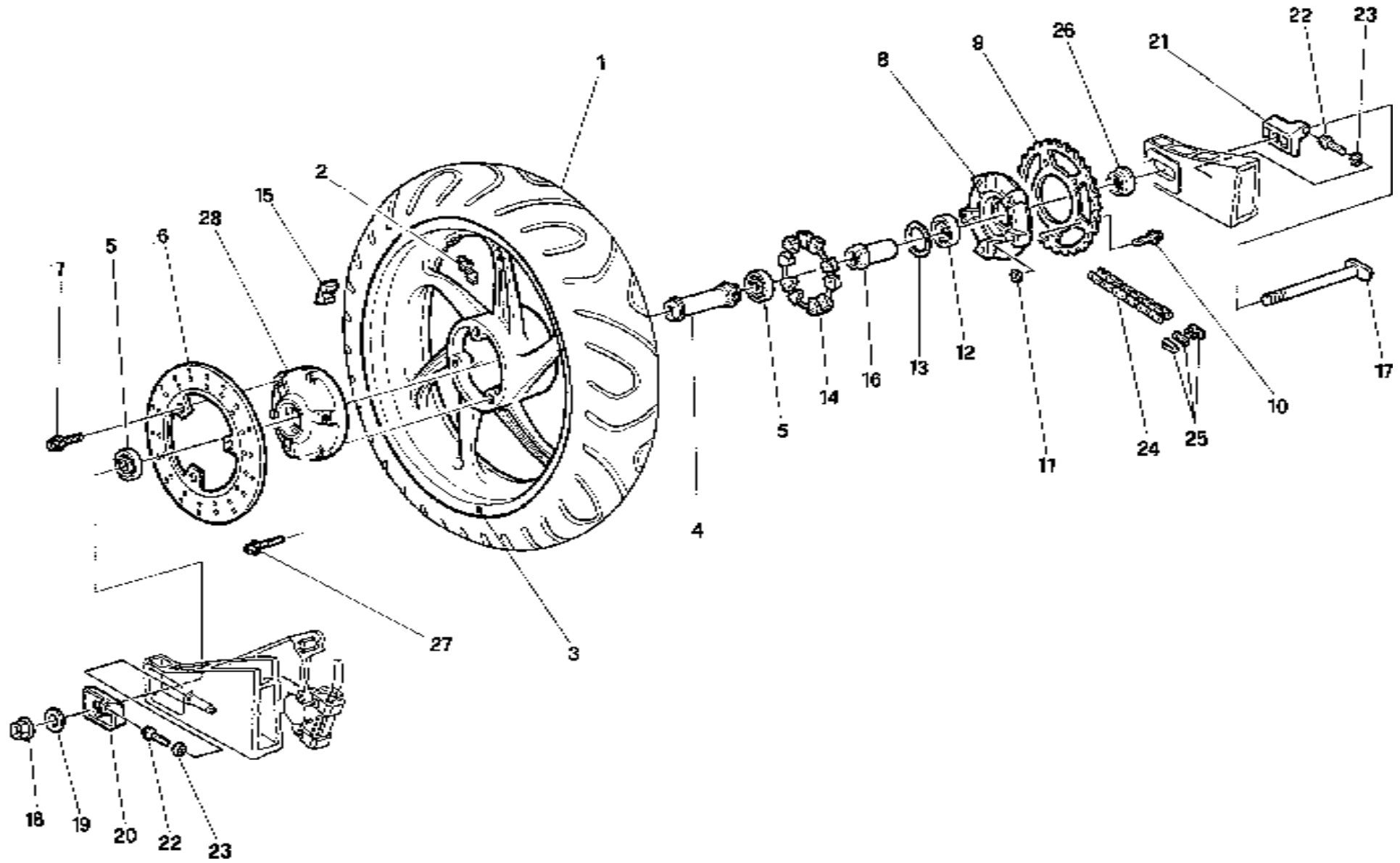

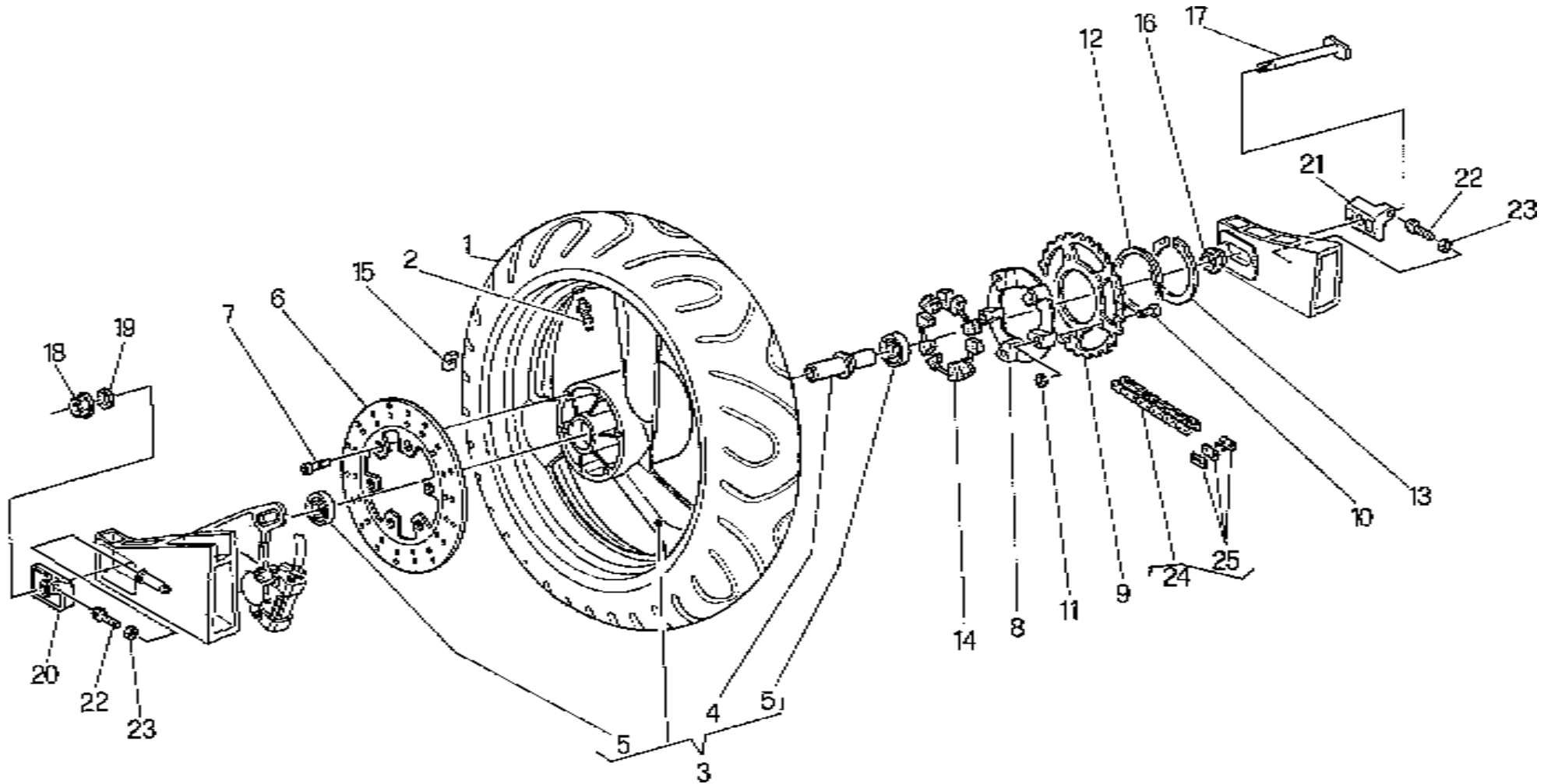

Note Notes Notas	Pos. No. N. Index	N° Codice Code No. Nr. Code Code Nr. N. Cod.	Q.tà Q.ty Q.te M.ge C.ad	DENOMINAZIONE	NAME	DESIGNATION	BESHREIBUNG	DENOMINACION	Validità Validity Validité Gültig Valides
	2	8000 43384	1	Valvola	Valve	Soupape	Ventil	Válvula	
	3	8F00 62611	1	Cerchio ruota com.	Wheel rim assy	Jante roue com.	Radfelge kpl.	Llanta rueda com.	
	4	8000 62617	1	Distanziale interno	Spacer	Entretoise	Distanzstück	Separador	
	5	8000 15659	2	Cuscinetto	Bearing	Roulement	Lager	Cojinete	
	6	8000 62615	1	Disco freno	Brake disc	Disque frein	Bremsscheibe	Disco freno	
	7	7715 6642B	6	Vite fissaggio disco	Screw	Vis	Schraube	Tornillo	
	8	80G0 62607	1	Supporto	Support	Support	Halterung	Soporte	
	9	8C00 62609	1	Corona Z = 43	Ring gear Z = 43	Couronne Z = 43	Kranz Z = 43	Corona Z = 43	
	9	8000 82077	1	Corona Z = 41 (CH-A)	Ring gear Z = 41 (CH-A)	Couronne Z = 41 (CH-A)	Kranz Z = 41 (CH-A)	Corona Z = 41 (CH-A)	
D	9	8A00 82077	1	Corona Z = 43 (CH-A)	Ring gear Z = 43 (CH-A)	Couronne Z = 43 (CH-A)	Kranz Z = 43 (CH-A)	Corona Z = 43 (CH-A)	
	10	8000 62732	5	Vite	Screw	Vis	Schraube	Tornillo	
	11	8000 56410	5	Dado autobloccante	Nut	Ecrou	Mutter	Tuerca	
	12	8000 67947	1	Anello	Ring	Bague	Ring	Anillo	
	13	66N4 21229	1	Anello elastico	Split ring	Anneau ressort	Drahtspengring	Anillo elastico	
	14	8000 62608	1	Parastrappi	Flexible coupling	Pièce caoutchouc	Gummidämpfer	Para tirones	
	15	8000 42040	1	Placchetta bilanciatura	Balance wheight	Masse additive	Gewichtsausgleich	Placa equilibrio	
	16	8000 62610	1	Distanziale esterno	Spacer	Entretoise	Distanzstück	Separador	
	17	8000 62612	1	Perno	Pin	Pivot	Bolzen	Perno	
	18	8000 62613	1	Dado	Nut	Ecrou	Mutter	Tuerca	
	19	80A0 19963	1	Rosetta piana	Washer	Rondelle	Scheibe	Arandela	
	20	80A0 60689	1	Tendicatena destra	Chain adjuster	Tendeur de chaine	Kettenspanner	Tensor de cadena	
	21	80A0 60690	1	Tendicatena sinistra	Chain adjuster	Tendeur de chaine	Kettenspanner	Tensor de cadena	
	22	8000 62576	2	Vite	Screw	Vis	Schraube	Tornillo	
	23	80A0 67502	2	Dado	Nut	Ecrou	Mutter	Tuerca	
A	24	8E00 60831	1	Catena regina	Chain	Chaîne	Kette	Cadena	
A	24	8A00 79938	1	Catena takasago	Chain	Chaîne	Kette	Cadena	
	25	8000 47456	1	Giunto regina	Coupling	Joint	Kupplung	Junta	
	25	8000 79939	1	Giunto takasago	Coupling	Joint	Kupplung	Junta	
D				In dotazione (Kit 8000 87696)	To issue (Kit 8000 87696)	En necessaire (Kit 8000 87696)	Ausrüstungsteile (Kit 8000 87696)	En dotaciòn (Kit 8000 87696)	
A				In alternativa	In alternative	En alternative	Die Auswahl	En alternativa	

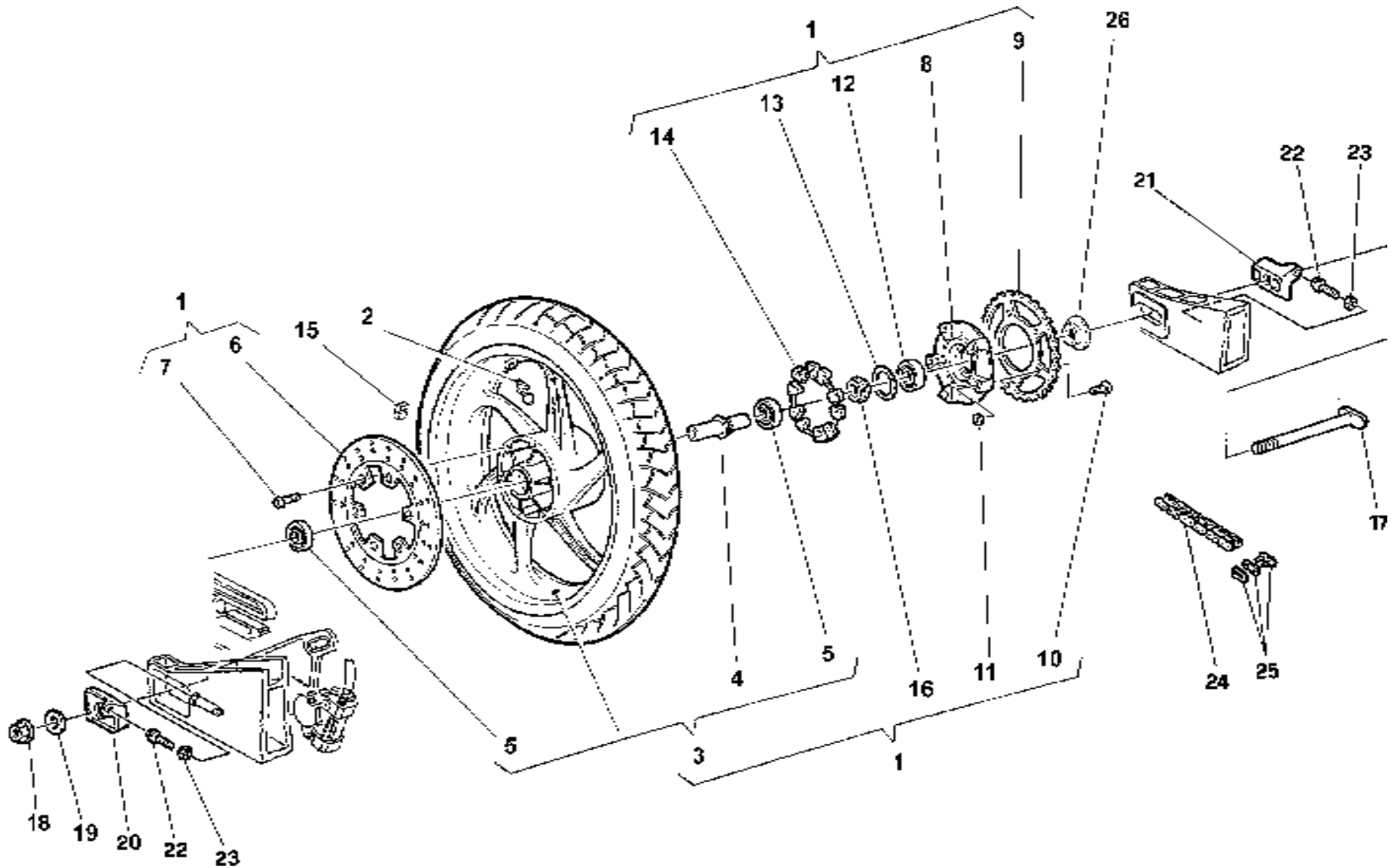

Note Notes Notas	Pos. No. N. Index Pos.	N° Codice Code No. Nr. Code Code Nr. N. Cod.	Q.tà Q.ty Q.te M.ge C.ad	DENOMINAZIONE	NAME	DESIGNATION	BESHREIBUNG	DENOMINACION	Validità Validity Validité Gültig Valides
	1	8000 91794	1	Ass. cerchio ruota posteriore (cod. colore A B C E F G)	Rear rim assy (Colour cod. A B C E F G)	Groupe jante arrière (cod. couleur A B C E F G)	Felgegruppe Kpl. (Cod. Farbe A B C E F G)	Grupo llanta rueda trasera (còd. colòr A B C E F G)	
	1	8B00 91794	1	Ass. cerchio ruota posteriore (cod. colore H L)	Rear rim assy (Colour cod. H L)	Groupe jante arrière (cod. couleur H L)	Felgegruppe Kpl. (Cod. Farbe H L)	Grupo llanta rueda trasera (còd. colòr H L)	
	2	8000 91796	1	Valvola	Valve	Soupape	Ventil	Válvula	
	3	8000 90545	1	Cerchio ruota posteriore (cod. colore A B C E F G)	Rear rim (Colour cod. A B C E F G)	Jante arrière (cod. couleur A B C E F G)	Felge (Cod. Farbe A B C E F G)	Llanta rueda trasera (còd. colòr A B C E F G)	
	3	8A00 90545	1	Cerchio ruota posteriore (cod. colore H L)	Rear rim (Colour cod. H L)	Jante arrière (cod. couleur H L)	Felge (Cod. Farbe H L)	Llanta rueda trasera (còd. colòr H L)	
	4	8A00 62606	1	Distanziale interno	Inside spacer	Entretoise int.	Distanzstück	Separador	
	5	8000 15659	2	Cuscinetto	Bearing	Roulement	Lager	Cojinete	
	6	8000 62615	1	Disco freno posteriore	Rear brake disc	Disque frein arr.	Bremsscheibe	Disco freno trasero	
	7	8000 53185	6	Vite	Screw	Vis	Schraube	Tornillo	
	8	80C0 78016	1	Flangia portacorona (cod. colore A B C E F G)	Flange (Colour cod. A B C E F G)	Bride (cod. couleur A B C E F G)	Flansch (Cod. Farbe A B C E F G)	Brida porta-corona (còd. colòr A B C E F G)	
	8	80B0 78016	1	Flangia portacorona (cod. colore H L)	Flange (Colour cod. H L)	Bride (cod. couleur H L)	Flansch (Cod. Farbe H L)	Brida porta-corona (còd. colòr H L)	
	9	8C00 62609	1	Corona z=43	Ring Gear z=43	Couronne z=43	Kranz z=43	Corona z=43	
	9	8000 62609	1	Corona z=41 (CH - A)	Ring Gear z=41 (CH - A)	Couronne z=41 (CH - A)	Kranz z=41 (CH - A)	Corona z=41 (CH - A)	
K	9	8C00 62609	1	Corona z=43 (CH - A)	Ring Gear z=43 (CH - A)	Couronne z=43 (CH - A)	Kranz z=43 (CH - A)	Corona z=43 (CH - A)	
	10	8000 62732	5	Vite	Screw	Vis	Schraube	Tornillo	
	11	8000 56410	5	Dado	Nut	Ecrou	Mutter	Tuerca	
	12	8A00 43567	1	Cuscinetto	Bearing	Roulement	Lager	Cojinete	
	13	66N0 21275	1	Anello elastico	Spring ring	Bague élastique	Sprengring	Anillo elástico	
	14	8000 62608	1	Parastrappi	Flexible coupling	Pièce caoutchouc	Gummidämpfer	Para-tirones	
	15	8000 42040	1	Placchetta bilanciatura	Balance wheight	Masse additive	Gewichtsausgleich	Placa equilibrio	
	16	8000 87573	1	Distanziale	Spacer	Entretoise	Distanzstück	Separador	
	17	8000 62612	1	Perno ruota posteriore	Rear wheel pin	Pivot roue arrière	Hinterradbolzen	Perno rueda trasera	
	18	8000 62613	1	Dado	Nut	Ecrou	Mutter	Tuerca	
	19	80A0 19963	1	Rosetta	Washer	Rondelle	Scheibe	Arandela	
	20	80A0 60689	1	Tendicatena destra	Chain adjuster	Tendeur de chaine	Kettenspanner	Tensor de cadena	
	21	80A0 60690	1	Tendicatena sinistra	Chain adjuster	Tendeur de chaine	Kettenspanner	Tensor de cadena	

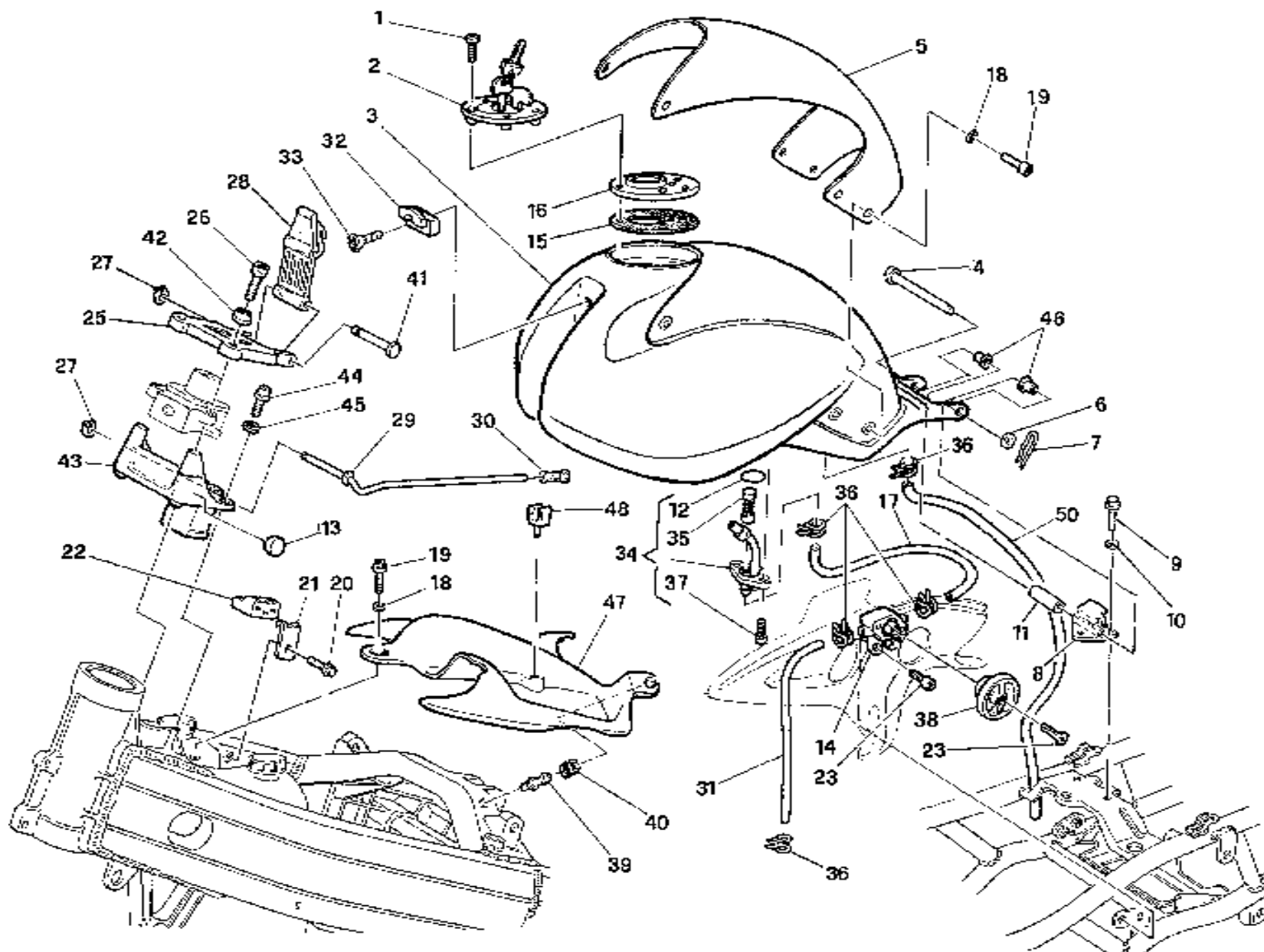

Note Notes Notas	Pos. No. N. Index	N° Codice Code No. Nr. Code Code Nr. N. Cod.	Q.tà Q.ty Q.te M.ge C.ad	DENOMINAZIONE	NAME	DESIGNATION	BESHREIBUNG	DENOMINACION	Validità Validity Validité Gültig Valides
	1	60N1 07330	1	Vite	Screw	Vis	Schraube	Tornillo	
	2	8000 66157	1	Tappo	Plug	Bouchon	Verschluss	Tapón	
	3	8000 85796	1	Serbatoio (codice colore A = 8E24)	Tank assy (colour code A = 8E24)	Réservoir (code couleur A = 8E24)	Tank (code fabre A = 8E24)	Depósito (codigo color A = 8E24)	
	3	8A00 85796	1	Serbatoio (codice colore B = 8E26)	Tank assy (colour code B = 8E26)	Réservoir (code couleur B = 8E26)	Tank (code fabre B = 8E26)	Depósito (codigo color B = 8E26)	
	3	8B00 85796	1	Serbatoio (codice colore C = 8E06)	Tank assy (colour code C = 8E06)	Réservoir (code couleur C = 8E06)	Tank (code fabre C = 8E06)	Depósito (codigo color C = 8E06)	
	3	8000 90150	1	Serbatoio (codice colore D = 8E36)	Tank assy (colour code D = 8E36)	Réservoir (code couleur D = 8E36)	Tank (code fabre D = 8E36)	Depósito (codigo color D = 8E36)	
	3	8000 92416	1	Serbatoio (codice colore E = 8E63)	Tank assy (colour code E = 8E63)	Réservoir (code couleur E = 8E63)	Tank (code fabre E = 8E63)	Depósito (codigo color E = 8E63)	
	3	8A00 92416	1	Serbatoio (codice colore F = 8E64)	Tank assy (colour code F = 8E64)	Réservoir (code couleur F = 8E64)	Tank (code fabre F = 8E64)	Depósito (codigo color F = 8E64)	
	3	8B00 92416	1	Serbatoio (codice colore G = 8E48)	Tank assy (colour code G = 8E48)	Réservoir (code couleur G = 8E48)	Tank (code fabre G = 8E48)	Depósito (codigo color G = 8E48)	
	3	8C00 92416	1	Serbatoio (codice colore H = 8E43)	Tank assy (colour code H = 8E43)	Réservoir (code couleur H = 8E43)	Tank (code fabre H = 8E43)	Depósito (codigo color H = 8E43)	
	3	8D00 92416	1	Serbatoio (codice colore L = 8E79)	Tank assy (colour code L = 8E79)	Réservoir (code couleur L = 8E79)	Tank (code fabre L = 8E79)	Depósito (codigo color L = 8E79)	
	4	8A00 66362	1	Perno	Pin	Pivot	Bolzen	Perno	
	5	80A0 85780	1	Copriserbatoio (codice colore A B C H L = 8A43)	Tank cover (colour code A B C H L = 8A43)	Couvre reservoir (code couleur A B C H L = 8A43)	Tankdeckung (code fabre A B C H L = 8A43)	Cubredepósito (codigo color A B C H L = 8A43)	
	5	8000 90142	1	Copriserbatoio (codice colore D = 8E38)	Tank cover (colour code D = 8E38)	Couvre reservoir (code couleur D = 8E38)	Tankdeckung (code fabre D = 8E38)	Cubredepósito (codigo color D = 8E38)	
	5	80C0 85780	1	Copriserbatoio (codice colore E = 8E43)	Tank cover (colour code E = 8E43)	Couvre reservoir (code couleur E = 8E43)	Tankdeckung (code fabre E = 8E43)	Cubredepósito (codigo color E = 8E43)	
	5	80D0 85780	1	Copriserbatoio (codice colore F = 8E65)	Tank cover (colour code F = 8E65)	Couvre reservoir (code couleur F = 8E65)	Tankdeckung (code fabre F = 8E65)	Cubredepósito (codigo color F = 8E65)	
	5	80E0 85780	1	Copriserbatoio (codice colore G = 8E64)	Tank cover (colour code G = 8E64)	Couvre reservoir (code couleur G = 8E64)	Tankdeckung (code fabre G = 8E64)	Cubredepósito (codigo color G = 8E64)	
	6	62N1 15549	2	Rosetta piana	Washer	Rondelle	Scheibe	Arandela	

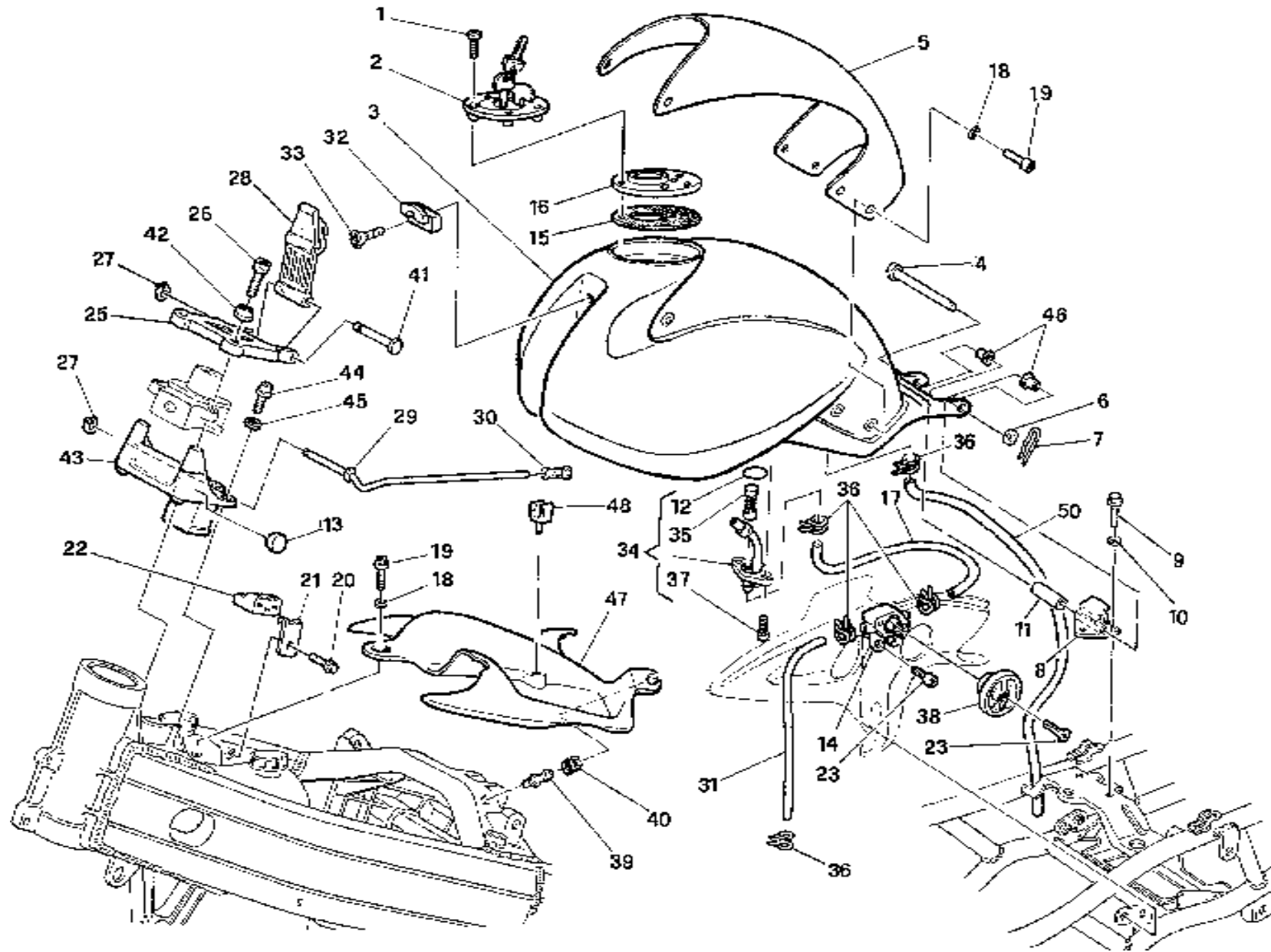

Note Notes Notas	Pos. No. N. Index Pos.	N° Codice Code No. Nr. Code Code Nr N. Cod.	Q.tà Q.ty Q.te M.ge C.ad	DENOMINAZIONE	NAME	DESIGNATION	BESHREIBUNG	DENOMINACION	Validità Validity Validité Gültig Valides
	7	8000 62705	1	Spinetta	Pin	Goupille	Stift	Clavija	
	8	8000 88324	1	Staffa	Bracket	Etrier	Buegel	Brida	
	9	8000 62725	3	Vite	Screw	Vis	Schraube	Tornillo	
	10	8000 04898	1	Rosetta	Washer	Rondelle	Scheibe	Arandela	
	11	8000 66363	1	Bussola	Bushing	Douille	Büchse	Manguito	
	12	8A00 34323	1	Guarnizione	Gasket	Garnitue	Dichtung	Junta	
	13	8000 88647	2	Gommino	Rubber	Pièce caoutchouc	Gummistück	Goma	
	14	8000 85800	1	Rubinetto	Cock assy	Robinet compl.	Kraftstoffahn, Kpl.	Llave de paso compl.	
	15	8000 66451	1	Guarnizione	Gasket	Garnitue	Dichtung	Junta	
	16	8000 66450	1	Ghiera	Ring nut	Embout	Nut mutter	Virola	
	17	8000 85862	1	Condotto	Duct	Conduit	Rohr	Conducto	
	18	8000 56391	1	Rosetta	Washer	Rondelle	Scheibe	Arandela	
	19	8000 55699	1	Vite	Screw	Vis	Schraube	Tornillo	
	20	8000 62726	2	Vite	Screw	Vis	Schraube	Tornillo	
	21	8000 78332	2	Piastrina	Plate	Plaquette	Plättchen	Placa	
	22	8000 77922	2	Tampone	Pad	Tampon	Stopfen	Tampón	
	23	8C00 62129	1	Vite	Screw	Vis	Schraube	Tornillo	
	24	8000 62726	2	Vite	Screw	Vis	Schraube	Tornillo	
	25	80A0 87122	1	Supporto	Support	Support	Halterung	Soporte	
	26	60N1 02522	2	Vite	Screw	Vis	Schraube	Tornillo	
	27	66N121307	2	Rondella elastica di ritegno	Washer	Rondelle	Scheibe	Arandela	
	28	8000 87585	1	Cinghietta	Belt	Courroie	Riemen	Correa	
	29	8000 86018	1	Astina	Control rod	Coulisseau	Steuerstange	Varilla	
	30	8000 62751	1	Terminale	Terminal	Terminal	Anschluss	Terminal	
	31	8I00 66360	1	Tubo benzina	Pipe	Tuyau	Rohr	Tubo	
	32	8000 70114	1	Gancio	Hook	Crochet	Haken	Gancho	
	33	60N1 02482	1	Vite	Screw	Vis	Schraube	Tornillo	
	34	8000 85844	1	Sonda riserva completa	Fuel level feler compl.	Sonde niveau carb. ansamble	Fuhler Kpl.	Sonda riserva compl.	
	35	8000 85846	1	Filtro benzina	Fuel filter	Filtre essence	Benzinfilter	Filtro gasolina	
	36	8000 75754	5	Fascetta	Clamp	Collier	Schelle	Banda	
	37	60N1 02505	2	Vite	Screw	Vis	Schraube	Tornillo	
	38	80A0 87018	1	Manopola rubinettobenzina	Fuel cock grip	Manchon p. le robinet de comb.	Kraftstoffahnmuffe	Manguitollave paso gasolina	

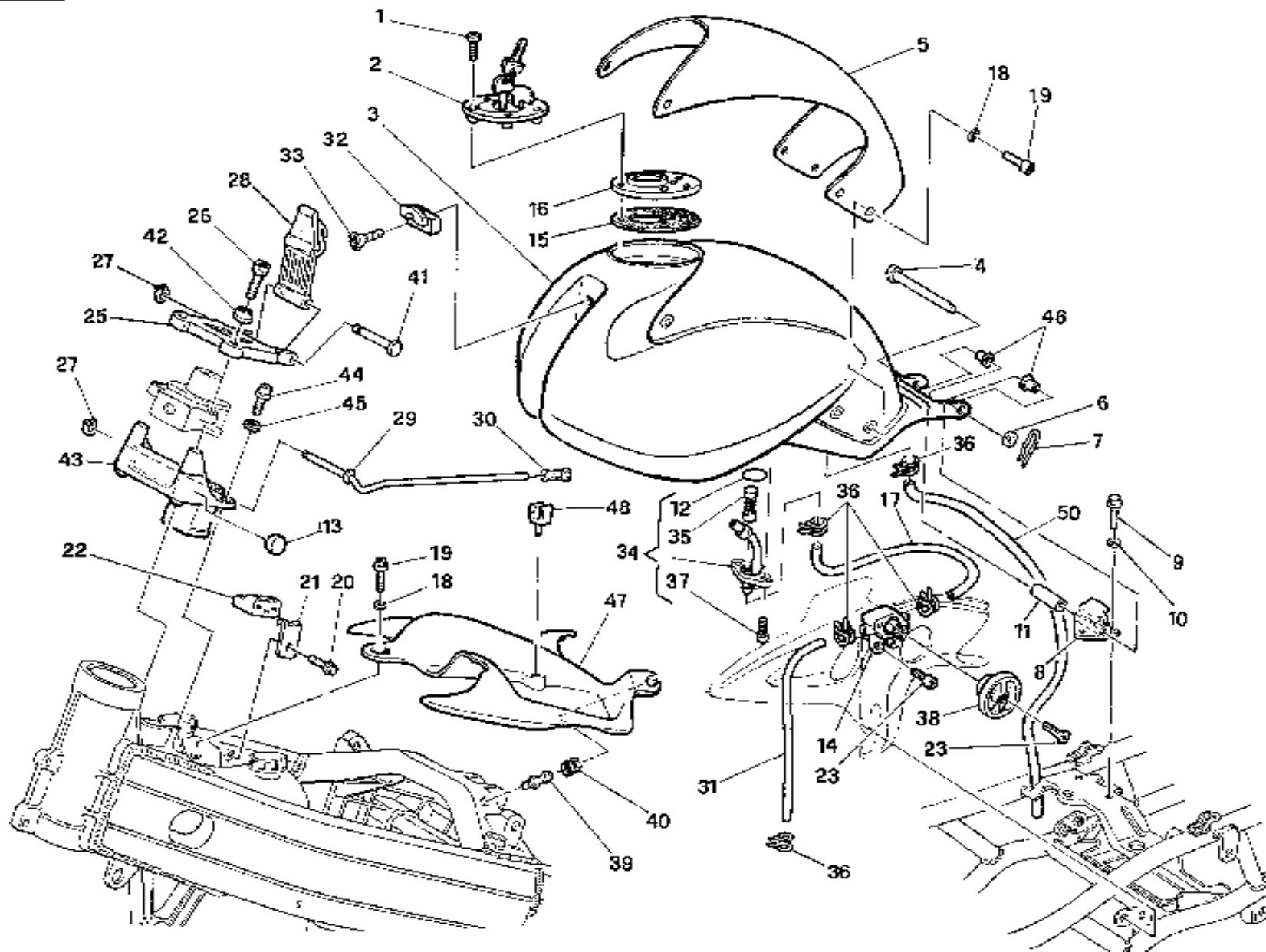

Note Notes Notas	Pos. No. N. Index Pos.	N° Codice Code No. Nr. Code Code Nr. N. Cod.	Q.tà Q.ty Q.te M.ge C.ad	DENOMINAZIONE	NAME	DESIGNATION	BESHREIBUNG	DENOMINACION	Validità Validity Validité Gültig Valides
	39	8000 66469	2	Perno	Pin	Pivot	Bolzen	Perno	
	40	8000 33662	2	Antivibrante	Silent-block	Antivibration	Schwingungsdämpfer	Anti-vibrador	
	41	8000 86375	1	Perno	Pin	Pivot	Bolzen	Perno	
	42	8000 85751	1	Rosetta carenata	Washer	Rondelle	Scheibe	Arandela	
	43	80A0 86015	1	Supporto	Support	Support	Halterung	Soporte	
	44	7715 6672B	2	Vite	Screw	Vis	Schraube	Tornillo	
	45	62N1 15504	2	Rosetta	Washer	Rondelle	Scheibe	Arandela	
	46	8000 87341	2	Distanziale	Spacer	Entretoise	Distanzstück	Separador	
	47	8000 85781	1	Supporto casco	Helmet support	Support casque	Helmhalterung	Soporte casco	
	48	8000 84686	1	Molletta	Spring	Ressort	Feder	Resorte	
	50	8000 93976	1	Tubo scarico benzina	Pipe	Tuyau	Rohr	Tubo	

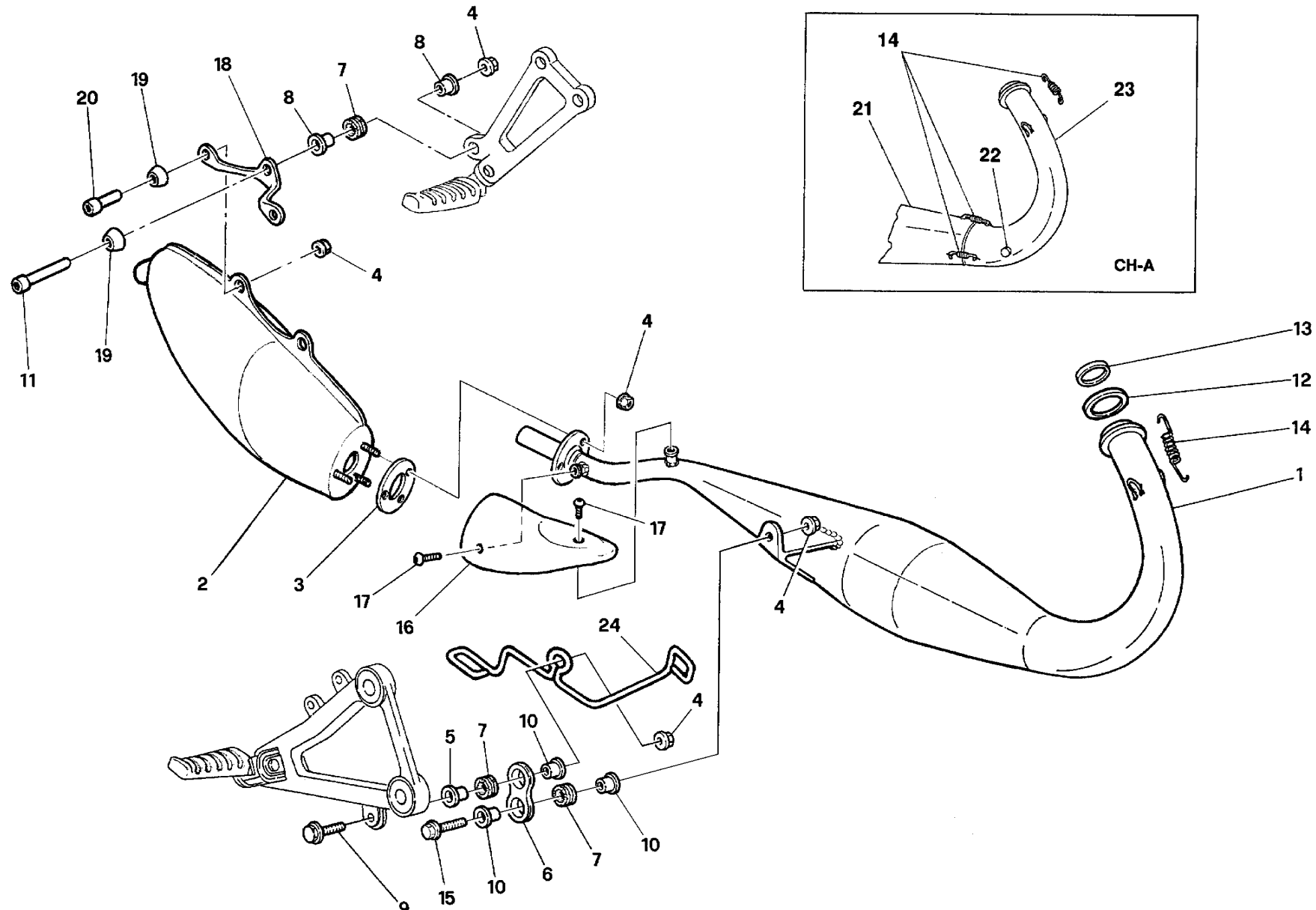

Note Notes Notas	Pos. No. N. Index	N° Codice Code No. Nr. Code Code Nr N. Cod.	Q.tà Q.ty Q.te M.ge C.ad	DENOMINAZIONE	NAME	DESIGNATION	BESHREIBUNG	DENOMINACION	Validità Validity Validité Gültig Valides
E	1	8000 99011	1	Tubo di scarico	Exhaust pipe	Tuyau d'échapp.	Auspuffrohr	Tubo de escape	
	2	8000 85813	1	Silenziatore	Silencer	Silencieux	Schalldampfer	Silenciador	
	2	8A00 85813	1	Silenziatore	Silencer	Silencieux	Schalldampfer	Silenciador	
	3	8000 88197	1	Guarnizione	Gasket	Garnitue	Dichtung	Junta	
	4	8000 44240	8	Dado	Nut	Ecrou	Mutter	Tuerca	
	5	8D00 62652	1	Distanziale	Spacer	Entretoise	Distanzstück	Separador	
	6	80A0 62649	1	Supporto	Support	Support	Halterung	Soporte	
	7	8000 62651	3	Silentblock	Silentblock	Silentblock	Silentblock	Silentblock	
	8	8B00 62652	2	Distanziale	Spacer	Entretoise	Distanzstück	Separador	
	9	8E00 67545	1	Vite	Screw	Vis	Schraube	Tornillo	
10	8000 95567	3	Distanziale	Spacer	Entretoise	Distanzstück	Separador		
11	7715 6722B	1	Vite	Screw	Vis	Schraube	Tornillo		
12	8000 46487	1	Anello OR	O Ring	Bague OR	O Ring	Anillo OR		
13	8000 27073	1	Guarnizione	Gasket	Garnitue	Dichtung	Junta		
14	8000 34924	2	Molla	Spring	Ressort	Feder	Resorte		
14	8000 62341	5	Molla (CH-A)	Spring (CH-A)	Ressort (CH-A)	Feder (CH-A)	Resorte (CH-A)		
15	8A00 67545	1	Vite	Screw	Vis	Schraube	Tornillo		
16	8000 87262	1	Protezione	Guard	Protection	Schutz	Protección		
17	80A0 59572	2	Vite	Screw	Vis	Schraube	Tornillo		
18	80A0 86014	1	Supporto (8E14)	Support (8E14)	Support (8E14)	Halterung (8E14)	Soporte (8E14)		
19	8000 85751	3	Rosetta carenata	Washer	Rondelle	Scheibe	Arandela		
20	7715 6672B	2	Vite	Screw	Vis	Schraube	Tornillo		
21	8000 89859	1	Parte post. scarico (CH-A)	Rear exhaust part (CH-A)	Partie arriere echapp. (CH-A)	Auspuffhinterteil (CH-A)	Parte trasera escape (CH-A)		
22	8000 47113	1	Vite a tappo (CH-A)	Screw (CH-A)	Vis (CH-A)	Schraube (CH-A)	Tornillo (CH-A)		
D	23	8000 90557	1	Parte ant. scarico (CH-A)	Front exhaust part (CH-A)	Prtie avant echapp. (CH-A)	Auspuffvorderteil (CH-A)	Parte delantera escape (CH-A)	
	23	8000 89858	1	Parte ant. scarico (CH-A)	Front exhaust part (CH-A)	Prtie avant echapp. (CH-A)	Auspuffvorderteil (CH-A)	Parte delantera escape (CH-A)	
24	8000 94671	1	Passacavo	Fairlead	Passecable	Kabelführung	Prensacable		
E				Ad esaurimento	To fell out	A' finir	Erschöpfung	A agotamiento	
D				In dotazione (Kit 8000 92713)	To issue (Kit 8000 92713)	En necessaire (Kit 8000 92713)	Ausrüstungsteile (Kit 8000 92713)	En dotación (Kit 8000 92713)	

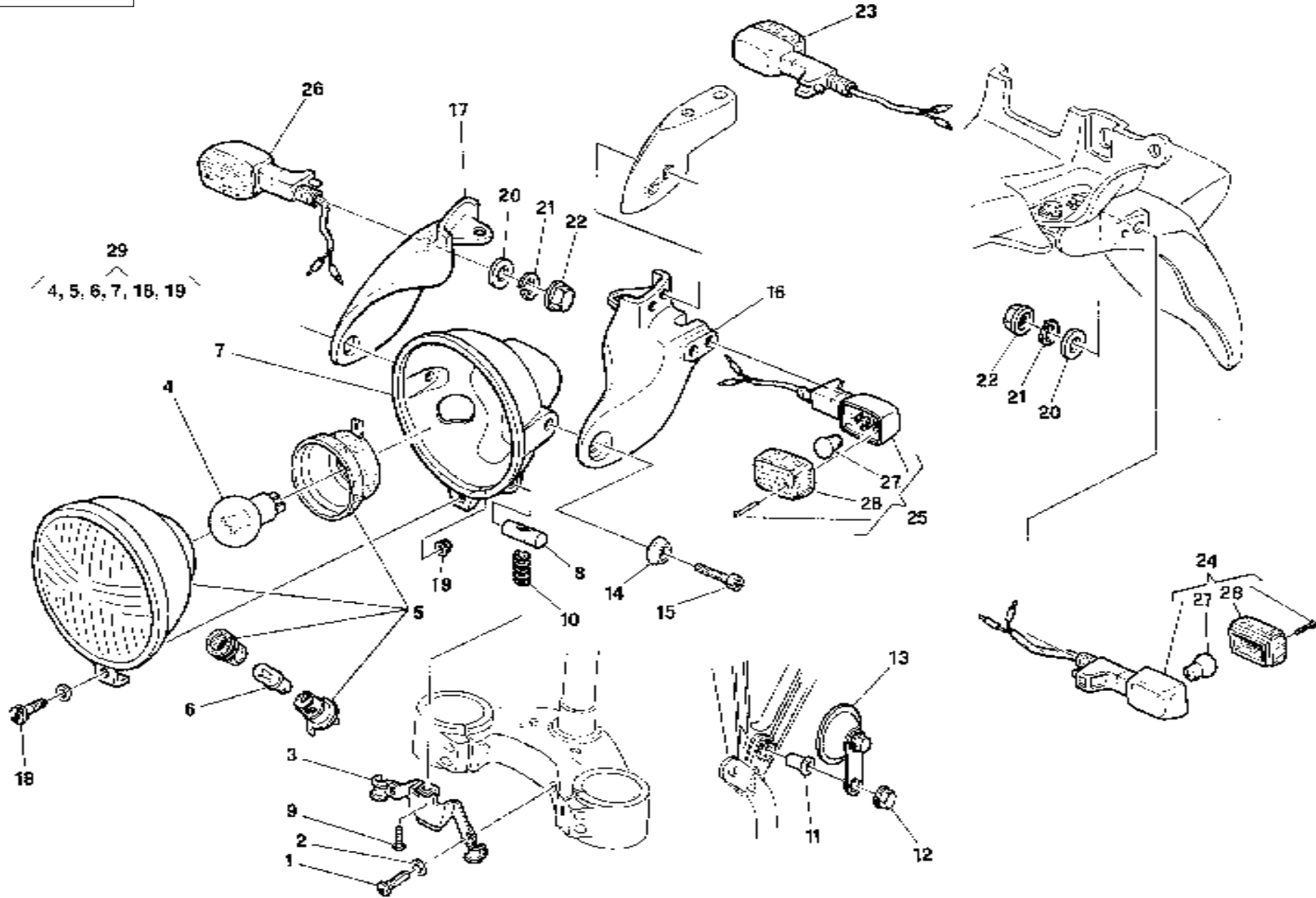

Note Notes Notas	Pos. No. Index	N° Codice Code No. Nr. Code Code Nr N. Cod.	Q.tà Q.ty Q.te M.ge C.ad	DENOMINAZIONE	NAME	DESIGNATION	BESHREIBUNG	DENOMINACION	Validità Validity Validité Gültig Valides
	1	8D00 61070	2	Vite	Screw	Vis	Schraube	Tornillo	
	2	62N1 15504	2	Rosetta	Washer	Rondelle	Scheibe	Arandela	
	3	8000 86010	1	Piastrina	Plate	Plaquette	Platte	Placa	
	4	8000 26675	1	Lampada biluce 12V 40/45W	Lamp 12V 40/45W	Lampe 12V 40/45W	Lampe 12V 40/45W	Lamparilla 12V 40/45W	
	4	8000 42946	1	Lampada bilux 12V 60/55W (GB)	Lamp 12V 60/55W (GB)	Lampe 12V 60/55W (GB)	Lampe 12V 60/55W (GB)	Lamparilla 12V 60/55W (GB)	
	5	3117 70101	1	Corpo riflettori con vetri	Bady reflector	Phare	Scheinwefer	Faro	
	5	8000 89914	1	Corpo riflettori con vetri (GB)	Bady reflector (GB)	Phare (GB)	Scheinwefer (GB)	Faro (GB)	
	6	0659 38226	2	Lampada città 12V 4W	Lamp 12V 4W	Lampe 12V 4W	Lampe 12V 4W	Lamparilla 12V 4W	
	7	8000 85581	1	Calotta	Cover	Calotte	Kappe	Tapa	
	8	8000 86009	1	Barilotto	Retainer	Cliquet	Sicherungsring	Barrilejo	
	9	8BA0 50798	1	Vite	Screw	Vis	Schraube	Tornillo	
	10	8000 62655	1	Molla	Spring	Ressort	Feder	Resorte	
	11	8AA0 32085	1	Distanziale	Spacer	Entretoise	Distanzstück	Separador	
	12	80B0 43928	1	Dado	Nut	Ecrou	Mutter	Tuerca	
	13	5164 0011A	1	Avvisatore acustico	Horn	Signal acoustique	Hupe	Avisador acustico	
	14	8000 87582	2	Rosettacarenata	Washer	Rondelle	Scheibe	Arandela	
	15	7715 7232B	2	Vite	Screw	Vis	Schraube	Tornillo	
	16	80A0 85783	1	Ass. supporto SX (codice colore A = 8E24)	L. support compl. (colour code A = 8E24)	Support compl. G. (code couleur A = 8E24)	Halter klp. L. (code fabre A = 8E24)	Soporte. I. (codigo color A = 8E24)	
	16	80B0 85783	1	Ass. supporto SX (codice colore B = 8E26)	L. support compl. (colour code B = 8E26)	Support compl. G. (code couleur B = 8E26)	Halter klp. L. (code fabre B = 8E26)	Soporte. I. (codigo color B = 8E26)	
	16	80C0 85783	1	Ass. supporto SX (codice colore C = 8E06)	L. support compl. (colour code C = 8E06)	Support compl. G. (code couleur C = 8E06)	Halter klp. L. (code fabre C = 8E06)	Soporte. I. (codigo color C = 8E06)	
	16	80D0 85783	1	Ass. supporto SX (codice colore D = 8E36)	L. support compl. (colour code D = 8E36)	Support compl. G. (code couleur D = 8E36)	Halter klp. L. (code fabre D = 8E36)	Soporte. I. (codigo color D = 8E36)	
	16	80E0 85783	1	Ass. supporto SX (codice colore E H = 8E43)	L. support compl. (colour code E H = 8E43)	Support compl. G. (code couleur E H = 8E43)	Halter klp. L. (code fabre E H = 8E43)	Soporte. I. (codigo color E H = 8E43)	
	16	80F0 85783	1	Ass. supporto SX (codice colore F = 8E64)	L. support compl. (colour code F = 8E64)	Support compl. G. (code couleur F = 8E64)	Halter klp. L. (code fabre F = 8E64)	Soporte. I. (codigo color F = 8E64)	
	16	80G0 85783	1	Ass. supporto SX (codice colore G = 8E48)	L. support compl. (colour code G = 8E48)	Support compl. G. (code couleur G = 8E48)	Halter klp. L. (code fabre G = 8E48)	Soporte. I. (codigo color G = 8E48)	

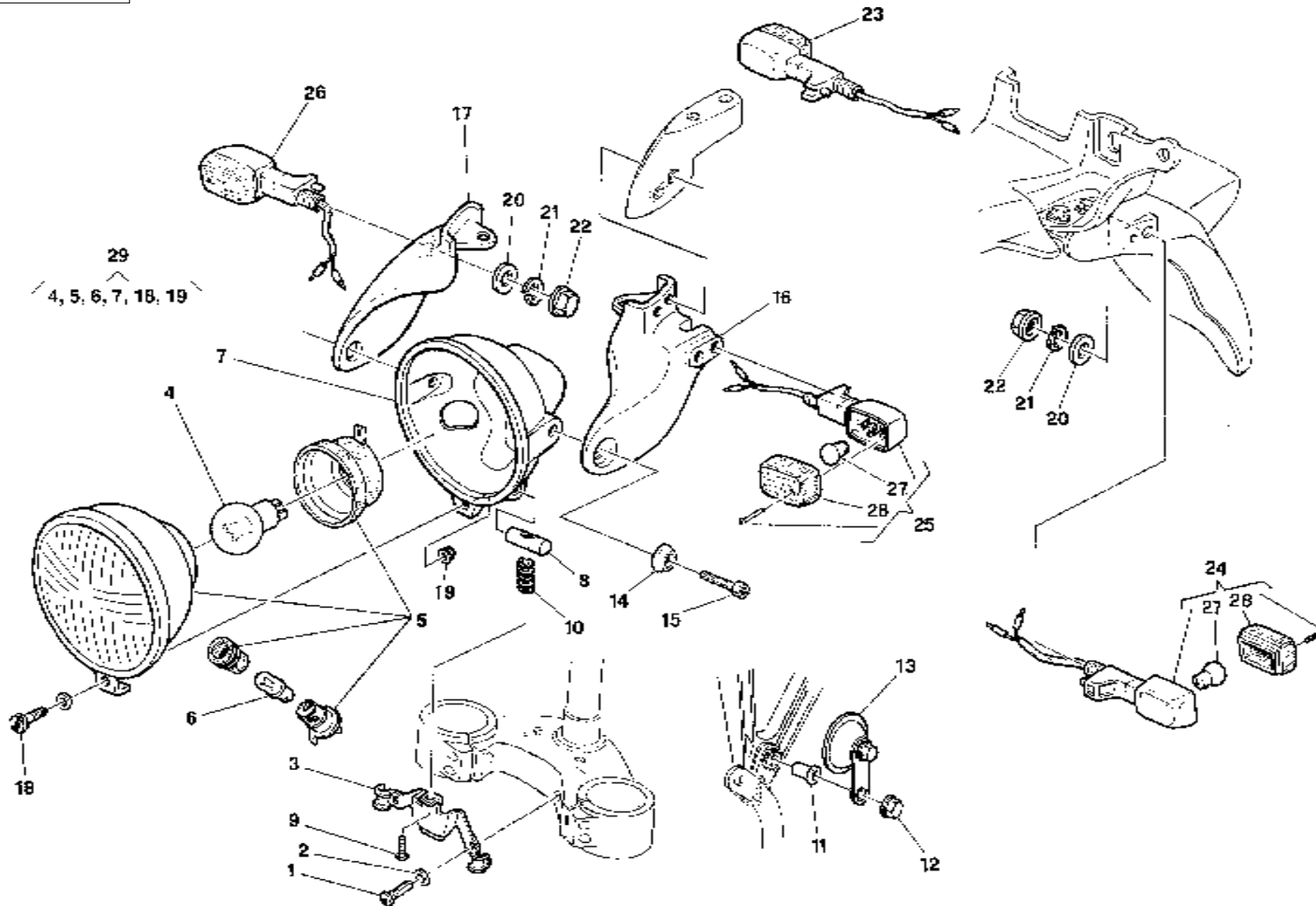

Note Notes Notas	Pos. No. N. Index	N° Codice Code No. Nr. Code Code Nr.	Q.tà Q.ty Q.te M.ge C.ad	DENOMINAZIONE	NAME	DESIGNATION	BESHREIBUNG	DENOMINACION	Validità Validity Validité Gültig Valides
	16	80H0 85783	1	Ass. supporto SX (codice colore L = 8E79)	L. support compl. (colour code L = 8E79)	Support compl. G. (code couleur L = 8E79)	Halter klp. L. (code fabre L = 8E79)	Soporte. I. (codigo color L = 8E79)	
	17	80A0 85782	1	Ass. supporto DX (codice colore A = 8E24)	R. support compl. (colour code A = 8E24)	Support compl. G. (code couleur A = 8E24)	Halter klp. R. (code fabre A = 8E24)	Soporte. D. (codigo color A = 8E24)	
	17	80B0 85782	1	Ass. supporto DX (codice colore B = 8E26)	R. support compl. (colour code B = 8E26)	Support compl. G. (code couleur B = 8E26)	Halter klp. R. (code fabre B = 8E26)	Soporte. D. (codigo color B = 8E26)	
	17	80C0 85782	1	Ass. supporto DX (codice colore C = 8E06)	R. support compl. (colour code C = 8E06)	Support compl. G. (code couleur C = 8E06)	Halter klp. R. (code fabre C = 8E06)	Soporte. D. (codigo color C = 8E06)	
	17	80D0 85782	1	Ass. supporto DX (codice colore D = 8E36)	R. support compl. (colour code D = 8E36)	Support compl. G. (code couleur D = 8E36)	Halter klp. R. (code fabre D = 8E36)	Soporte. D. (codigo color D = 8E36)	
	17	80E0 85782	1	Ass. supporto DX (codice colore E H = 8E43)	R. support compl. (colour code E H = 8E43)	Support compl. G. (code couleur E H = 8E43)	Halter klp. R. (code fabre E H = 8E43)	Soporte. D. (codigo color E H = 8E43)	
	17	80F0 85782	1	Ass. supporto DX (codice colore F = 8E64)	R. support compl. (colour code F = 8E64)	Support compl. G. (code couleur F = 8E64)	Halter klp. R. (code fabre F = 8E64)	Soporte. D. (codigo color F = 8E64)	
	17	80G0 85782	1	Ass. supporto DX (codice colore G = 8E48)	R. support compl. (colour code G = 8E48)	Support compl. G. (code couleur G = 8E48)	Halter klp. R. (code fabre G = 8E48)	Soporte. D. (codigo color G = 8E48)	
	17	80H0 85782	1	Ass. supporto DX (codice colore L = 8E79)	R. support compl. (colour code L = 8E79)	Support compl. G. (code couleur L = 8E79)	Halter klp. R. (code fabre L = 8E79)	Soporte. D. (codigo color L = 8E79)	
	18	60N1 03213	1	Vite	Screw	Vis	Schraube	Tornillo	
	19	8000 61335	1	Dado	Nut	Ecrou	Mutter	Tuerca	
	20	62N1 15507	4	Rosetta	Washer	Rondelle	Scheibe	Arandela	
	21	62N1 15540	4	Rosetta elastica	Spring washer	Rondelle élastique	Federscheibe	Arandela elástica	
	22	61N1 15058	4	Dado	Nut	Ecrou	Mutter	Tuerca	
	23	8000 85798	1	Indicatore di direz. post. DX	Blinker	Clignotant	Blinker	Intermittente	
	24	8000 85797	1	Indicatore di direz. post. SX	Blinker	Clignotant	Blinker	Intermittente	
	25	8000 85793	1	Indicatore di direz. ant. SX	Blinker	Clignotant	Blinker	Intermittente	
	26	8000 85794	1	Indicatore di direz. ant. DX	Blinker	Clignotant	Blinker	Intermittente	
	27	8000 36726	4	Lampada 12V 10W	Lamp 12V 10W	Lampe 12V 10W	lampe 12V 10W	Lamparilla 12V 10W	
	28	8000 74507	4	Lente	Lens	Loupe	Linse	Lente	
	29	8000 85548	1	Ass. proiettore anteriore	Headlamp assy	Groupe projecteur	Scheinwerfergruppe Kpl.	Grupo projector	
	29	8000 89892	1	Ass. proiettore anteriore (GB)	Headlamp assy (GB)	Groupe projecteur (GB)	Scheinwerfergruppe Kpl. (GB)	Grupo projector (GB)	

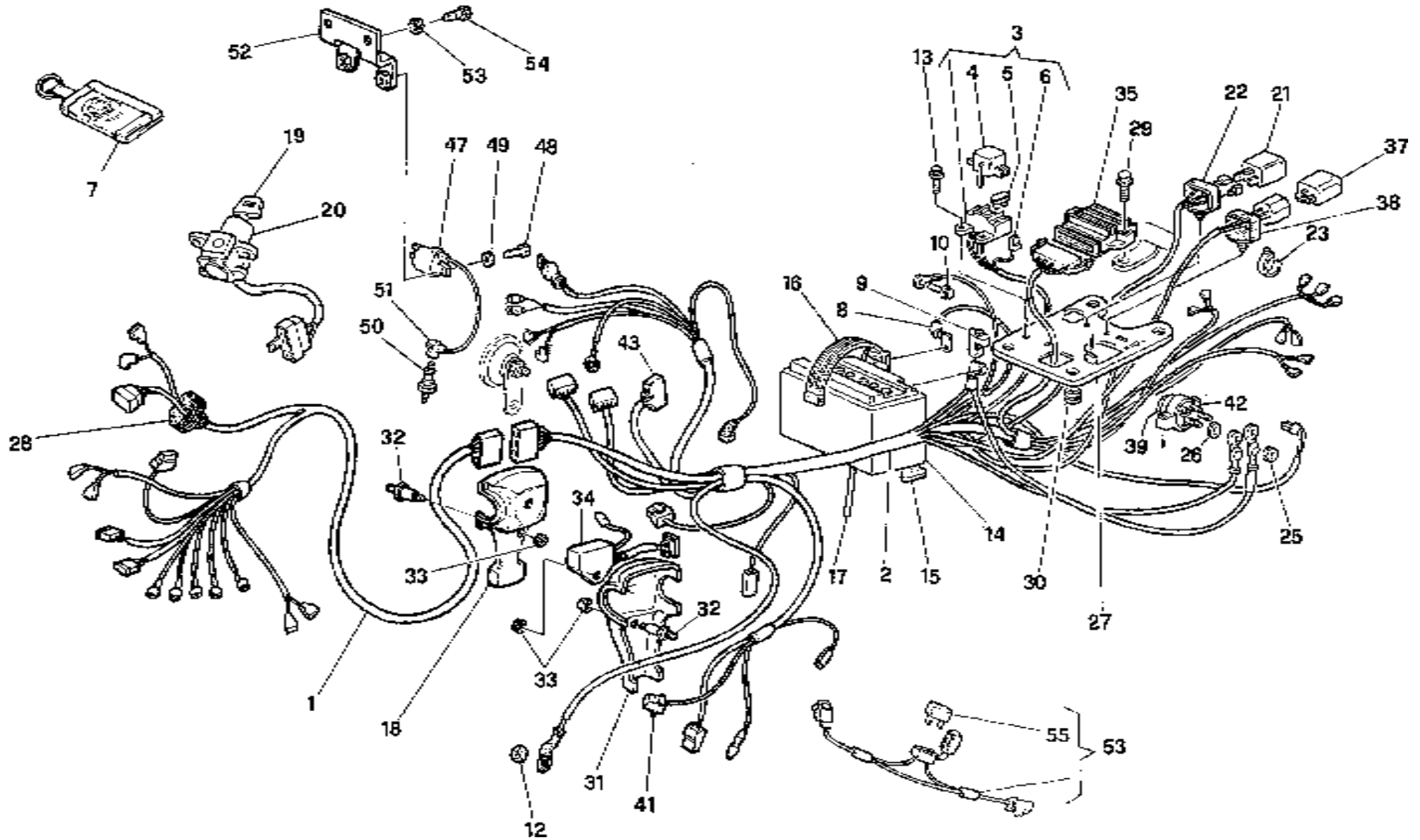

Note Notes Notas	Pos. No. N. Index Pos.	N° Codice Code No. Nr. Code Code Nr N. Cod.	Q.tà Q.ty Q.te M.ge C.ad	DENOMINAZIONE	NAME	DESIGNATION	BESHREIBUNG	DENOMINACION	Validità Validity Validité Gültig Valides
	1	8000 85788	1	Gruppo cavi anteriore	Cable	Cables	Kabel	Grupo cables	
	2	8000 85789	1	Gruppo cavi	Cable	Cables	Kabel	Grupo cables	
	3	8000 58400	1	Portafusibili	Fuse holder	Boîte à fusibles	Sicherungshalter	Portafusibles	
	4	8000 49887	1	Coperchietto	Cover	Couvercle	Deckel	Tapa	
	5	8000 47472	4	Fusibile 15A	Fuse	Fusible	Sicherung	Fusible	
	6	8000 58402	4	Terminale	Terminal	Terminal	Anschluss	Terminal	
	7	8000 60994	1	Portachiavi	Keyring	Porteclefs	Schlüsselring	Llavero	
	8	8000 78847	2	Terminale	Terminal	Terminal	Anschluss	Terminal	
	9	8000 78350	1	Cappuccio	Cap	Capuschon	Kappe	Capuchon	
	10	8000 62725	1	Vite	Screw	Vis	Schraube	Tornillo	
	12	8000 56443	1	Dado	Nut	Ecrou	Mutter	Tuerca	
	13	8000 66525	2	Vite	Screw	Vis	Schraube	Tornillo	
	14	8000 54372	1	Batteria	Battery	Batterie	Batterie	Bateria	
	15	8000 66339	4	Tampone	Pad	Tampon	Stopfen	Tampón	
	16	8000 66340	1	Cinghietta	Belt	Courroie	Riemen	Correa	
	17	8B00 66536	1	Sfiato	Breather pipe	Évent	Entlüfter	Purga	
	18	8000 86376	1	Coperchietto DX	Cover	Couvercle	Deckel	Tapa	
	19	8000 66159	1	Chiave grezza	Key	Clé	Schüssel	Llave	
	20	8000 77770	1	Interruttore accensione	Switch	Interrupteur	Schalter	Interruptor	
	21	8000 88173	1	Intermittenza indicat. di direz.	Flash device	Intermittence	Blinkgeber	Intermitencia	
	22	8000 67548	1	Supporto elastico	Support	Support	Halterung	Soporte	
	23	8000 71578	10	Fascetta in gomma	Clamp	Collier	Schelle	Banda	
	25	61N1 15062	2	Dado	Nut	Ecrou	Mutter	Tuerca	
	26	62N1 15767	2	Rondella elastica	Washer	Rondelle	Scheibe	Arandela	
	27	8000 62677	1	Pannello posteriore	Panel	Panneau	Streifen	Panel	
	28	8000 86374	1	Gommino	Rubber	Pièce caoutchouc	Gummstück	Goma	
	29	8000 62728	2	Vite	Screw	Vis	Schraube	Tornillo	
	30	8000 62645	4	Piolo elastico	Elastic peg	Échelon élastique	Elastischer Zapfen	Espiga elástica	
	31	8000 67949	1	Coperchietto SX	Cover	Couvercle	Deckel	Tapa	
	32	8000 67948	1	Perno	Pin	Pivot	Bolzen	Perno	
	33	8000 56443	3	Dado	Nut	Ecrou	Mutter	Tuerca	
	34	8000 59394	1	Centralina elettronica	Electronic device	Dispositif électronique	Zündelektronik	Centralita electrónica	

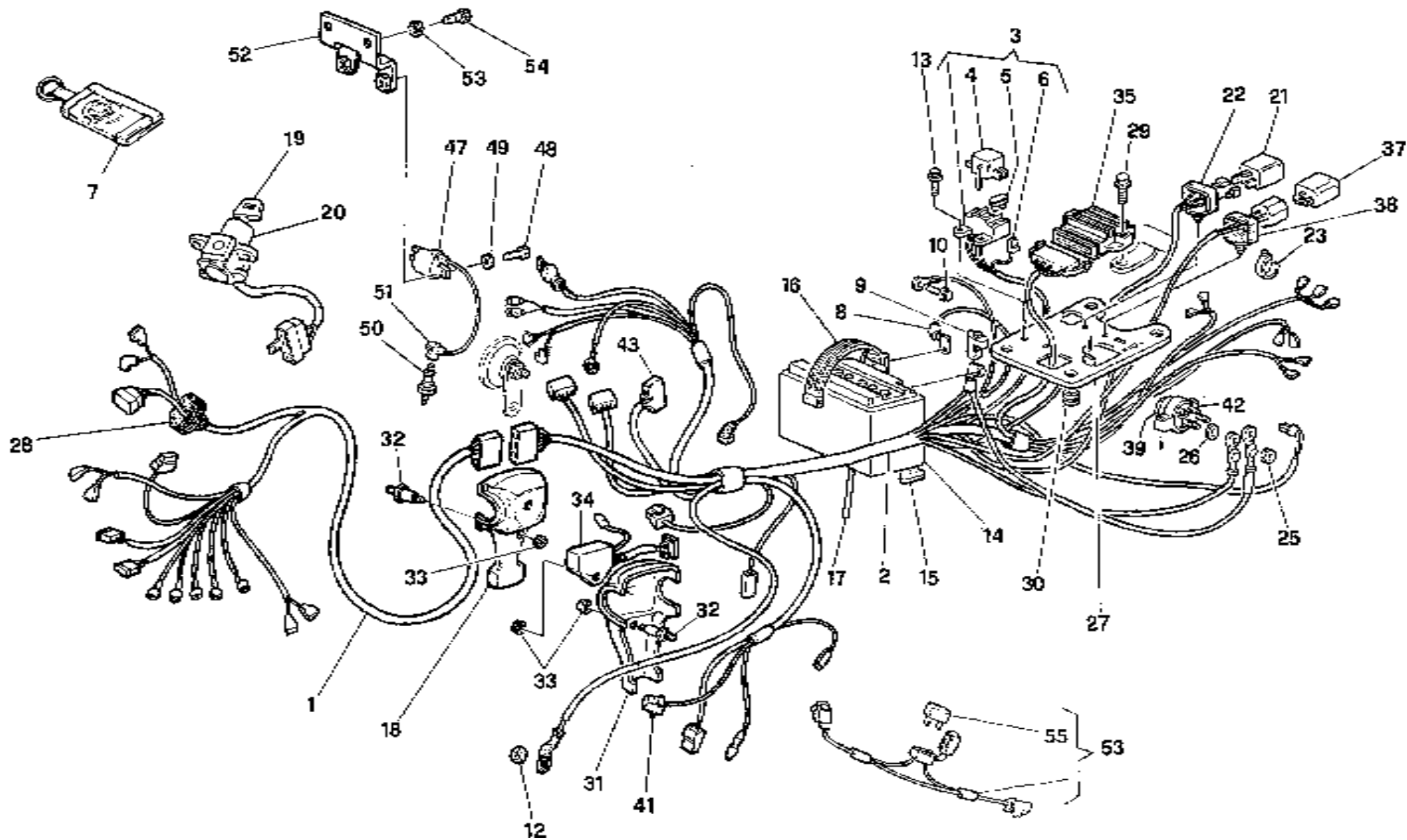

Note Notes Notas	Pos. No. N. Index Pos.	N° Codice Code No. Nr. Code Code Nr N. Cod.	Q.tà Q.ty Q.te M.ge C.ad	DENOMINAZIONE	NAME	DESIGNATION	BESHREIBUNG	DENOMINACION	Validità Validity Validité Gültig Valides
	35	8000 42274	1	Regolatore di tensione	Voltage rectifier	Régulateur de tension	Spannungsregler	Regulador de tensión	
A	37	8000 89846	1	Centralina avviamento	Starting system	Distributeur démarrage	Elektronik für Anlass	Centralita arranque	
	37	8000 90046	1	Centralina avviamento	Starting system	Distributeur démarrage	Elektronik für Anlass	Centralita arranque	
	38	8000 67548	1	Supporto elastico	Support	Support	Halterung	Soporte	
	39	39740011A	1	Teleruttore avviamento	Solenoid starter	Télerupteur démarrage	Fernschlatter für das	Telerruptor arranque	
	41	8000 60052	1	Connettore a due vie	Connector	Connecteur	Verbinder	Conector	
	42	8000 66803	1	Supporto	Support	Support	Halterung	Soporte	
	43	8000 66526	1	Connettore a sei vie	Connector	Connecteur	Verbinder	Conector	
	47	8A00 42272	1	Bobina	Coil	Bobine	Zündspule	Bobina	
	48	8000 62728	2	Vite	Screw	Vis	Schraube	Tornillo	
	50	8A00 57446	1	Candela NGK	Spark plug	Bougie	Zündkerze	Bujía	
A	50	8000 88759	1	Candela CHAMPION QN 84	Spark plug	Bougie	Zündkerze	Bujía	
	51	8000 90877	1	Pipetta schermata	Pipette	Pipette	Pipette	Pipa	
A	51	8000 75270	1	Pipetta schermata	Pipette	Pipette	Pipette	Pipa	
	52	8000 86790	1	Supporto centralina	Support	Support	Halterung	Soporte	
	53	8000 90582	1	Cavo contr.attuatore-centralina controllo avviamento	Valve opening control-starting system cable	Cableau controleouverture clapet-distributeur démarage	Kabel KontrolleVentil Öffnung-Elektronik für anlass	Cable control apertura válvula- -centralita de arranque	
	54	8000 62725	2	Vite	Screw	Vis	Schraube	Tornillo	
	55	8000 47467	1	Fusibile 3A	Fuse 3A	Fusible 3A	Sicherung 3A	Fusible 3A	
A				In alternativa	In alternative	En alternative	Wahlweise	En alternativa	

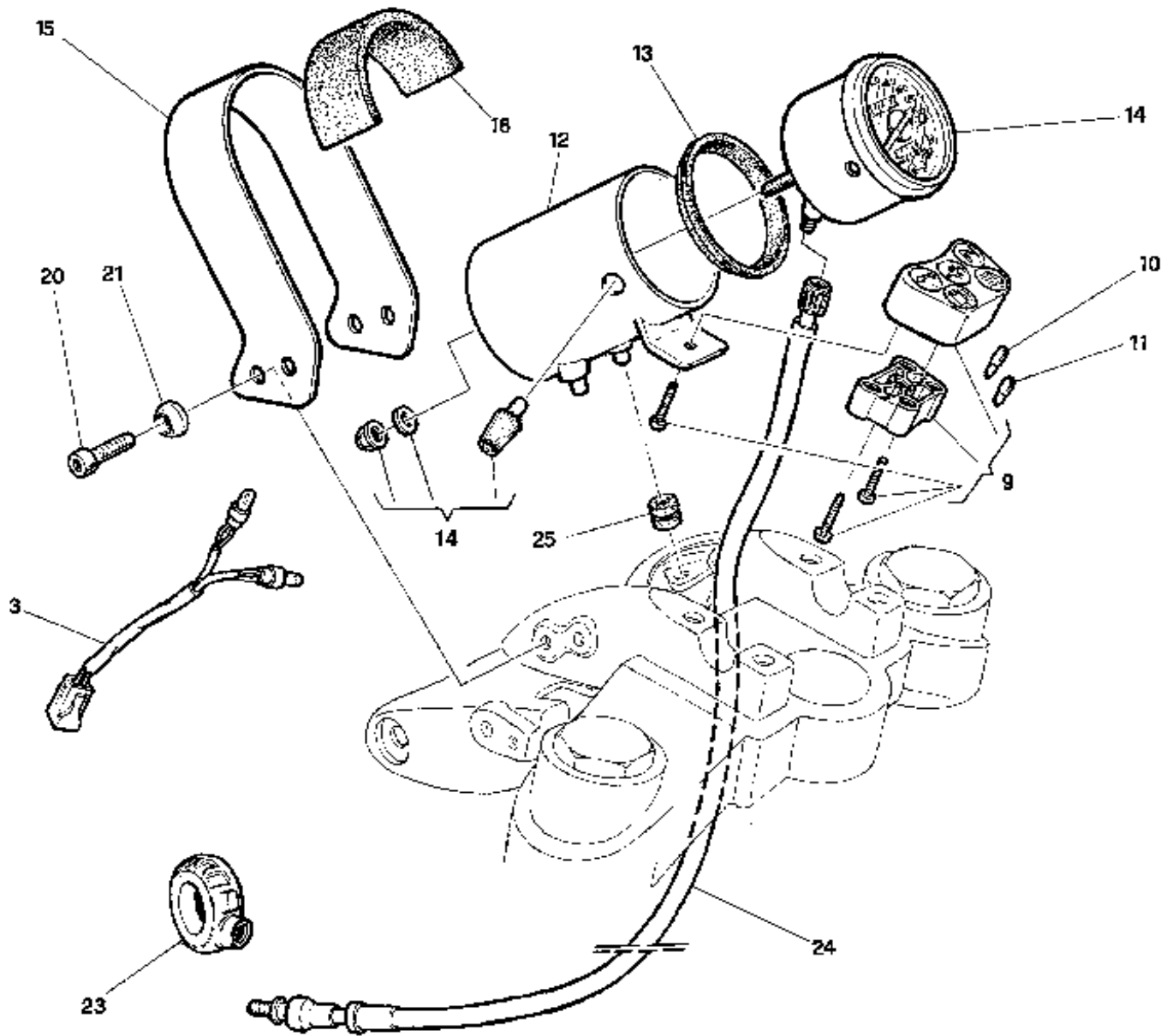

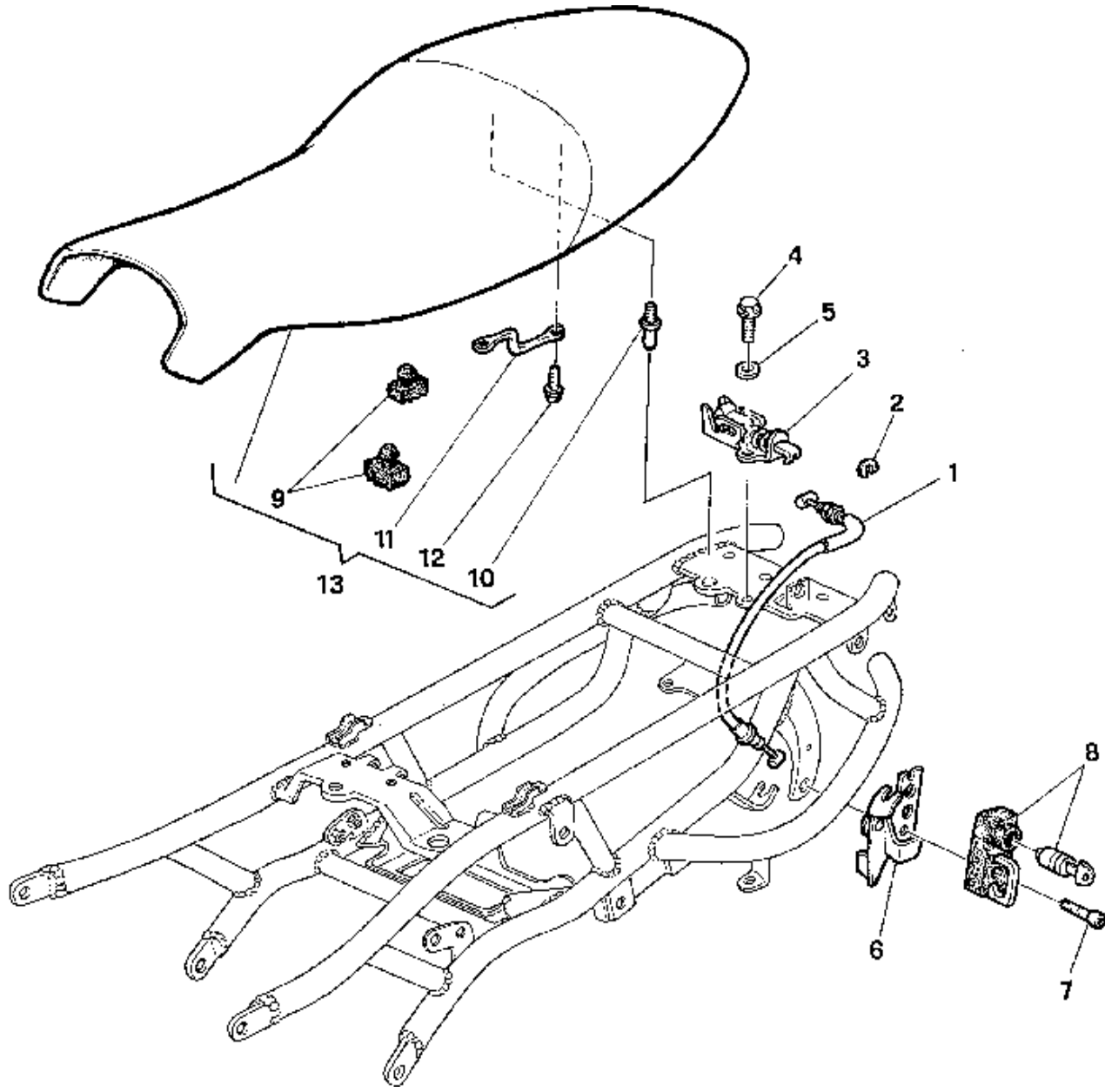

Note Notes Notes Marke Notas	Pos. No. N. Index Pos.	N° Codice Code No. Nr. Code Code Nr N. Cod.	Q.tà Q.ty Q.te M.ge C.ad	DENOMINAZIONE	NAME	DESIGNATION	BESHREIBUNG	DENOMINACION	Validità Validity Validité Gültig Valides
	1	8000 86012	1	Trasmissione chiusura sella	Saddle lock transmission	Transmission fermeture selle	Antrieb Sattelverschluss	Transmisión cerre sillin	
	2	66N0 21308	1	Anello SEEGER	SEEGER ring	Anneau SEEGER	Ring SEEGER	Anillo SEEGER	
	3	8000 63003	1	Chiavistello per sella	Latch	Verrou	Riegel	Cerrojo	
	4	8000 66525	1	Vite	Screw	Vis	Schraube	Tornillo	
	5	62N1 15766	1	Rosetta	Washer	Rondelle	Scheibe	Arandela	
	6	8000 66441	1	Dispositivo chiusura sella	Saddle lock device	Dispositif fermeture selle	Richtungsattelverschluss	Dispositivo cerre sillin	
	7	8000 58140	1	Vite	Screw	Vis	Schraube	Tornillo	
	8	8000 66156	1	Serratura con chiavi	Lock with keys	Serrure avec clés	Schloss mit Schlüssel	Cerradura con llaves	
	9	8661 0191A	5	Tampone	Pad	Tampon	Stopfen	Tampòn	
	10	8A00 84445	1	Perno	Pin	Pivot	Zapfen	Clavija	
	11	8000 63007	1	Cavallotto	U-bolt	Cavalier	Schraube	Tornillo	
	12	8000 62726	2	Vite	Screw	Vis	Schraube	Tornillo	
	13	8000 85814	1	Sella (codice colore A-B-C)	Seat (colour code A-B-C)	Siège (code couleur A-B-C)	Sattel (Code Farbe A-B-C)	Sillín (codigo colòr A-B-C)	
	13	8A00 85814	1	Sella (codice colore D)	Seat (colour code D)	Siège (code couleur D)	Sattel (Code Farbe D)	Sillín (codigo colòr D)	
	13	8B00 85814	1	Sella (codice colore E-H)	Seat (colour code E-H)	Siège (code couleur E-H)	Sattel (Code Farbe E-H)	Sillín (codigo colòr E-H)	
	13	8C00 85814	1	Sella (codice colore F)	Seat (colour code F)	Siège (code couleur F)	Sattel (Code Farbe F)	Sillín (codigo colòr F)	
	13	8D00 85814	1	Sella (codice colore G)	Seat (colour code G)	Siège (code couleur G)	Sattel (Code Farbe G)	Sillín (codigo colòr G)	
	13	8E00 85814	1	Sella (codice colore L)	Seat (colour code L)	Siège (code couleur L)	Sattel (Code Farbe L)	Sillín (codigo colòr L)	

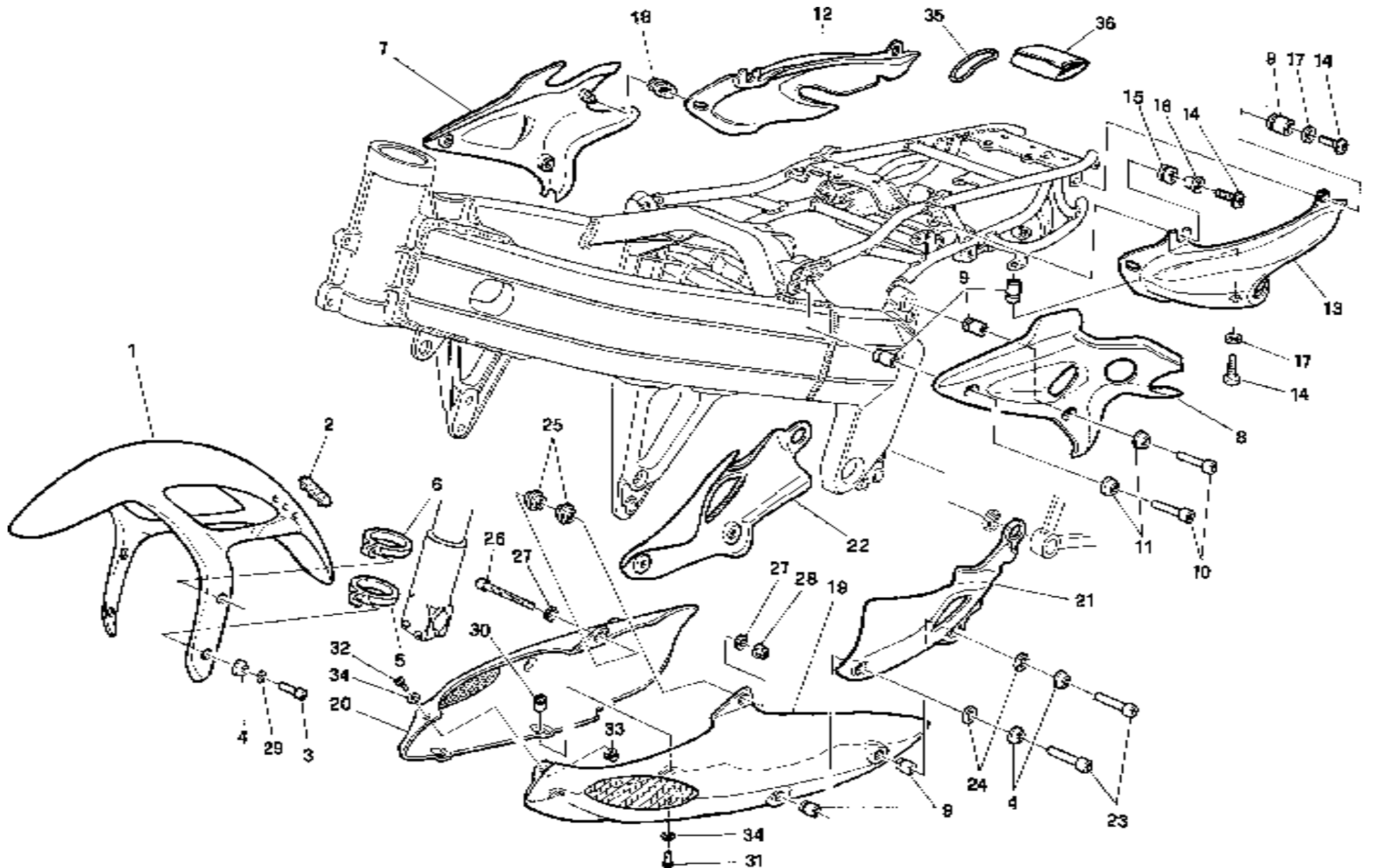

Note Notes Notas	Pos. No. N. Index	N° Codice Code No. Nr. Code Code Nr N. Cod.	Q.tà Q.ty Q.te M.ge C.ad	DENOMINAZIONE	NAME	DESIGNATION	BESHREIBUNG	DENOMINACION	Validità Validity Validité Gültig Valides
	1	80A0 85767	1	Parafango anteriore (codice colore A = 8E24)	Front mudguard (colour code A = 8E24)	Garde boue avant (code couleur A = 8E24)	Vord. Kotfluegel (code fabre A = 8E24)	Guarda barro delantero (codigo color A = 8E24)	
	1	80B0 85767	1	Parafango anteriore (codice colore B = 8E26)	Front mudguard (colour code B = 8E26)	Garde boue avant (code couleur B = 8E26)	Vord. Kotfluegel (code fabre B = 8E26)	Guarda barro delantero (codigo color B = 8E26)	
	1	80C0 85767	1	Parafango anteriore (codice colore C = 8E06)	Front mudguard (colour code C = 8E06)	Garde boue avant (code couleur C = 8E06)	Vord. Kotfluegel (code fabre C = 8E06)	Guarda barro delantero (codigo color C = 8E06)	
	1	80D0 85767	1	Parafango anteriore (codice colore D = 8E38)	Front mudguard (colour code D = 8E38)	Garde boue avant (code couleur D = 8E38)	Vord. Kotfluegel (code fabre D = 8E38)	Guarda barro delantero (codigo color D = 8E38)	
	1	80E0 85767	1	Parafango anteriore (codice colore E H = 8E43)	Front mudguard (colour code E H = 8E43)	Garde boue avant (code couleur E H = 8E43)	Vord. Kotfluegel (code fabre E H = 8E43)	Guarda barro delantero (codigo color E H = 8E43)	
	1	80F0 85767	1	Parafango anteriore (codice colore F = 8E65)	Front mudguard (colour code F = 8E65)	Garde boue avant (code couleur F = 8E65)	Vord. Kotfluegel (code fabre F = 8E65)	Guarda barro delantero (codigo color F = 8E65)	
	1	80G0 85767	1	Parafango anteriore (codice colore G = 8E48)	Front mudguard (colour code G = 8E48)	Garde boue avant (code couleur G = 8E48)	Vord. Kotfluegel (code fabre G = 8E48)	Guarda barro delantero (codigo color G = 8E48)	
	1	80H0 85767	1	Parafango anteriore (codice colore L = 8E79)	Front mudguard (colour code L = 8E79)	Garde boue avant (code couleur L = 8E79)	Vord. Kotfluegel (code fabre L = 8E79)	Guarda barro delantero (codigo color L = 8E79)	
	2	8000 81875	1	Gommino	Rubber	Pièce caoutchouc	Gummstück	Goma	
	3	7715 6672B	4	Vite	Screw	Vis	Schraube	Tornillo	
	4	8000 85751	8	Rosetta carenata	Washer	Rondelle	Scheibe	Arandela	
	5	80B0 70133	1	Fascetta	Clamp	Collier	Schelle	Banda	
	6	80B0 70127	3	Fascetta	Clamp	Collier	Schelle	Banda	
	7	8000 85768	1	Fianch. sella Dx (c.c. A B C H L)	R.H. saddle panel (c.c.A B C H L)	Flanc siège D. (c. c.A B C H L)	Sattelwange R(C.Far.A B C H L)	Panel sillin der. (c. c. A B C H L)	
	7	80A0 85768	1	Fianchetto sella Dx (codice colore D = 8E36)	R.H. saddle panel (colour code D = 8E36)	Flanc siège D. (code couleur D = 8E36)	Sattelwange R (code fabre D = 8E36)	Panel sillin der. (codigo color D = 8E36)	
	7	80B0 85768	1	Fianchetto sella Dx (codice colore E F G = 8E63)	R.H. saddle panel (colour code E F G = 8E63)	Flanc siège D. (code couleur E F G = 8E63)	Sattelwange R (code fabre E F G = 8E63)	Panel sillin der. (codigo color E F G = 8E63)	
	8	8000 85769	1	Fianch. sella Sx (c.c. A B C H L)	L.H. saddle panel (c.c.A B C H L)	Flanc siège G. (c.c.A B C H L)	Sattelwange L (C.Far.A B C H L)	Panel sillin iz. (c. c. A B C H L)	
	8	80A0 85769	1	Fianchetto sella Sx (codice colore D = 8E36)	L.H. saddle panel (colour code D = 8E36)	Flanc siège G. (code couleur D = 8E36)	Sattelwange L (code fabre D = 8E36)	Panel sillin iz. (codigo color D = 8E36)	
	8	80B0 85769	1	Fianchetto sella Sx (codice colore E F G = 8E63)	L.H. saddle panel (colour code E F G = 8E63)	Flanc siège G. (code couleur E F G = 8E63)	Sattelwange L (code fabre E F G = 8E63)	Panel sillin iz. (codigo color E F G = 8E63)	
	9	8000 48245	12	Dado elastico	Elastic nut	Ecrou	Mutter	Tuerca	

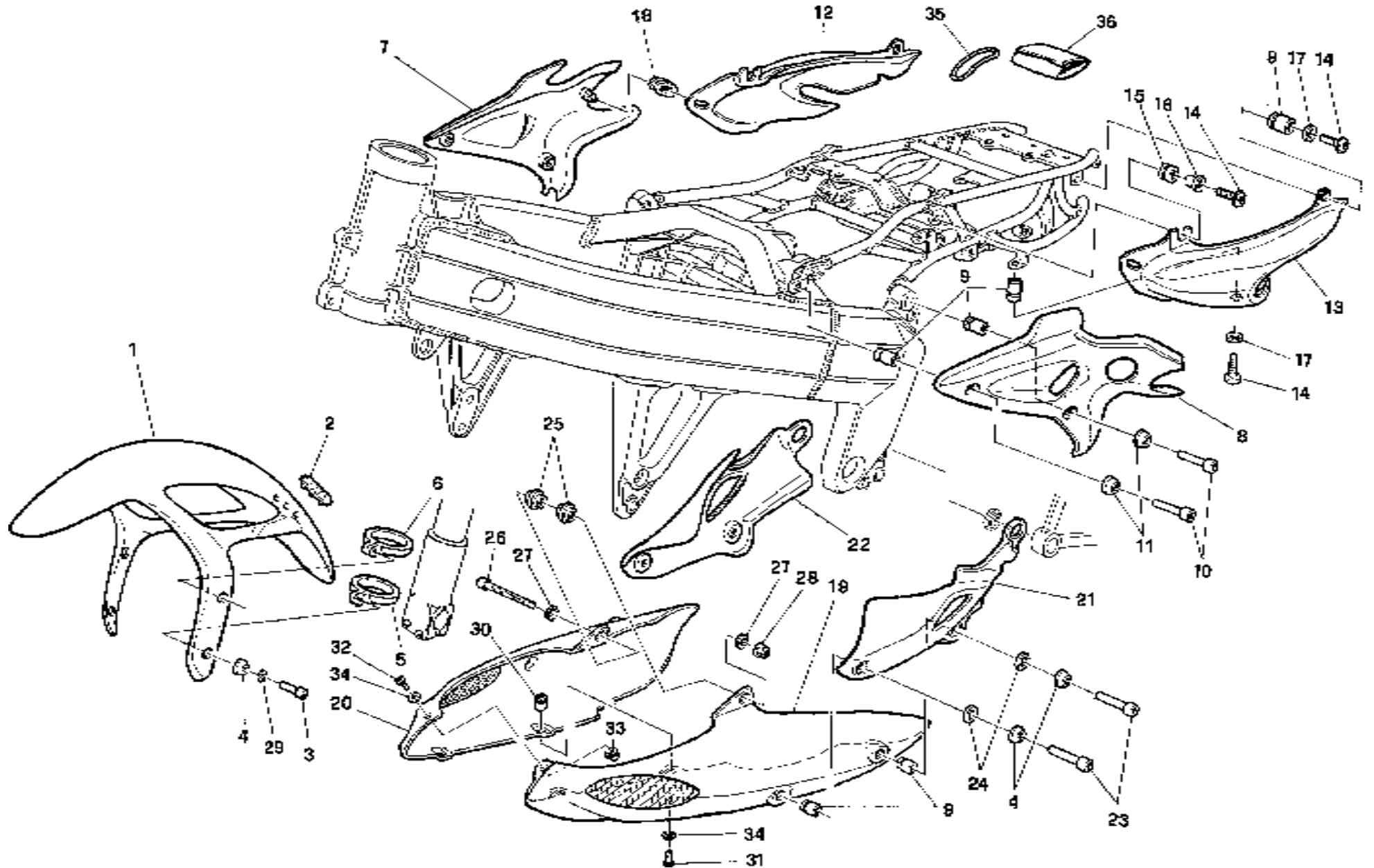

Note Notes Notas	Pos. No. N. Index	N° Codice Code No. Nr. Code Code Nr N. Cod.	Q.tà Q.ty Q.te M.ge C.ad	DENOMINAZIONE	NAME	DESIGNATION	BESHREIBUNG	DENOMINACION	Validità Validity Validité Gültig Valides
	10	7715 6672B	4	Vite	Screw	Vis	Schraube	Tornillo	
	11	8000 85751	2	Rosetta	Washer	Rondelle	Scheibe	Arandela	
	12	80A0 85770	1	Fianch. codone Dx (codice colore A B C = 8D71)	R.H. tail panel (colour code A B C = 8D71)	Flanc queu D. (code couleur A B C = 8D71)	Heckwange R (code fabre A B C = 8D71)	Panel cola der. (codigo color A B C = 8D71)	
	12	80B0 85770	1	Fianch. codone Dx (codice colore D = 8E36)	R.H. tail panel (colour code D = 8E36)	Flanc queu D. (code couleur D = 8E36)	Heckwange R (code fabre D = 8E36)	Panel cola der. (codigo color D = 8E36)	
	12	80C0 85770	1	Fianch. codone Dx (codice colore E F G H L = 8E64)	R.H. tail panel (colour code E F G H L = 8E64)	Flanc queu D. (code couleur E F G H L = 8E64)	Heckwange R (code fabre E F G H L = 8E64)	Panel cola der. (codigo color E F G H L = 8E64)	
	13	80A0 85771	1	Fianch. codone Sx (codice colore A B C = 8D71)	L.H. tail panel (colour code A B C = 8D71)	Flanc queu G. (code couleur A B C = 8D71)	Hecklwange L. (code fabre A B C = 8D71)	Panel cola iz. (codigo color A B C = 8D71)	
	13	80B0 85771	1	Fianch. codone Sx (codice colore D = 8E36)	L.H. tail panel (colour code D = 8E36)	Flanc queu G. (code couleur D = 8E36)	Hecklwange L. (code fabre D = 8E36)	Panel cola iz. (codigo color D = 8E36)	
	13	80C0 85771	1	Fianch. codone Sx (codice colore E F G H L = 8E64)	L.H. tail panel (colour code E F G H L = 8E64)	Flanc queu G. (code couleur E F G H L = 8E64)	Hecklwange L. (code fabre E F G H L = 8E64)	Panel cola iz. (codigo color E F G H L = 8E64)	
	14	80C0 55698	6	Vite	Screw	Vis	Schraube	Tornillo	
	15	8000 18048	2	Antivibrante	Silent block	Antivibration	Schwingungsdämpfer	Anti vibrador	
	16	8000 62416	2	Distanziale	Spacer	Entretoise	Distanzstück	Separador	
	17	8000 56391	4	Rosetta in nylon	Washer	Rondelle	Scheibe	Arandela	
	18	8000 41874	2	Gommino	Rubber	Pièce caoutchouch	Gummistück	Goma	
	19	8000 85773	1	Puntale Sx (codice colore A = 8E24)	L.H. nose (colour code A = 8E24)	Queu G. (code couleur A = 8E24)	Querruder Unt. L. (code fabre A = 8E24)	Puntal iz. (codigo color A = 8E24)	
	19	8A00 85773	1	Puntale Sx (codice colore B = 8E26)	L.H. nose (colour code B = 8E26)	Queu G. (code couleur B = 8E26)	Querruder Unt. L. (code fabre B = 8E26)	Puntal iz. (codigo color B = 8E26)	
	19	8B00 85773	1	Puntale Sx (codice colore C = 8E06)	L.H. nose (colour code C = 8E06)	Queu G. (code couleur C = 8E06)	Querruder Unt. L. (code fabre C = 8E06)	Puntal iz. (codigo color C = 8E06)	
	19	8C00 85773	1	Puntale Sx (codice colore D = 8E38)	L.H. nose (colour code D = 8E38)	Queu G. (code couleur D = 8E38)	Querruder Unt. L. (code fabre D = 8E38)	Puntal iz. (codigo color D = 8E38)	
	19	8D00 85773	1	Puntale Sx (codice colore E = 8E43)	L.H. nose (colour code E = 8E43)	Queu G. (code couleur E = 8E43)	Querruder Unt. L. (code fabre E = 8E43)	Puntal iz. (codigo color E = 8E43)	
	19	8E00 85773	1	Puntale Sx (codice colore F = 8E65)	L.H. nose (colour code F = 8E65)	Queu G. (code couleur F = 8E65)	Querruder Unt. L. (code fabre F = 8E65)	Puntal iz. (codigo color F = 8E65)	

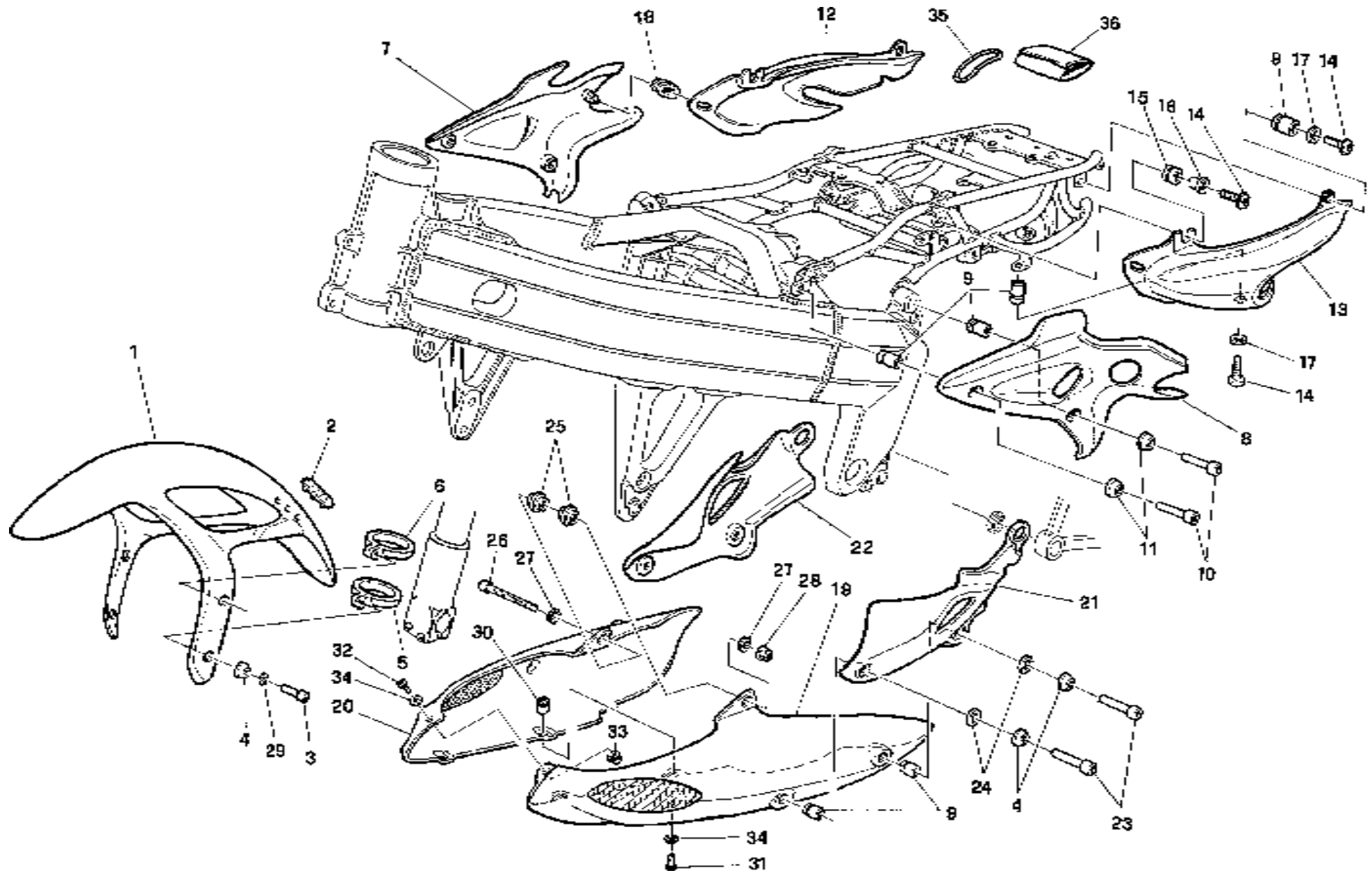

Note Notes Notas	Pos. No. N. Index Pos.	N° Codice Code No. Nr. Code Code Nr. N. Cod.	Q.tà Q.ty Q.te M.ge C.ad	DENOMINAZIONE	NAME	DESIGNATION	BESHREIBUNG	DENOMINACION	Validità Validity Validité Gültig Valides
	19	8F00 85773	1	Puntale Sx (codice colore G = 8E48)	L.H. nose (colour code G = 8E48)	Queu G. (code couleur G = 8E48)	Querruder Unt. L. (code fabre G = 8E48)	Puntal iz. (codigo color G = 8E48)	
	20	8000 85772	1	Puntale Dx (codice colore A = 8E24)	R.H. nose (colour code A = 8E24)	Queu D. (code couleur A = 8E24)	Querruder Unt. R (code fabre A = 8E24)	Puntal der. (codigo color A = 8E24)	
	20	8A00 85772	1	Puntale Dx (codice colore B = 8E26)	R.H. nose (colour code B = 8E26)	Queu D. (code couleur B = 8E26)	Querruder Unt. R (code fabre B = 8E26)	Puntal der. (codigo color B = 8E26)	
	20	8B00 85772	1	Puntale Dx (codice colore C = 8E06)	R.H. nose (colour code C = 8E06)	Queu D. (code couleur C = 8E06)	Querruder Unt. R (code fabre C = 8E06)	Puntal der. (codigo color C = 8E06)	
	20	8C00 85772	1	Puntale Dx (codice colore D = 8E38)	R.H. nose (colour code D = 8E38)	Queu D. (code couleur D = 8E38)	Querruder Unt. R (code fabre D = 8E38)	Puntal der. (codigo color D = 8E38)	
	20	8D00 85772	1	Puntale Dx (codice colore E = 8E43)	R.H. nose (colour code E = 8E43)	Queu D. (code couleur E = 8E43)	Querruder Unt. R (code fabre E = 8E43)	Puntal der. (codigo color E = 8E43)	
	20	8E00 85772	1	Puntale Dx (codice colore F = 8E65)	R.H. nose (colour code F = 8E65)	Queu D. (code couleur F = 8E65)	Querruder Unt. R (code fabre F = 8E65)	Puntal der. (codigo color F = 8E65)	
	20	8F00 85772	1	Puntale Dx (codice colore G = 8E48)	R.H. nose (colour code G = 8E48)	Queu D. (code couleur G = 8E48)	Querruder Unt. R (code fabre G = 8E48)	Puntal der. (codigo color G = 8E48)	
	21	8000 85779	1	Supp. puntale Sx (c. c. A-B-C)	L.H. nose support (c. c. A-B-C)	Queu support G. (c. c. A-B-C)	Querruderhalterung L (C. F. A-B-C)	Soporte puntal iz. (c. c. A-B-C)	
	21	80A0 85779	1	Supporto puntale Sx (codice colore D = 8E36)	L.H. nose support (colour code D = 8E36)	Queu support G. (code couleur D = 8E36)	Querruderhalterung L (code fabre D = 8E36)	Soporte puntal iz. (codigo color D = 8E36)	
	21	80B0 85779	1	Supporto puntale Sx (codice colore E F G = 8E63)	L.H. nose support (colour code E F G = 8E63)	Queu support G. (code couleur E F G = 8E63)	Querruderhalterung L (code fabre E F G = 8E63)	Soporte puntal iz. (codigo color E F G = 8E63)	
	22	8000 85778	1	Supp. puntale Dx (c. c. A-B-C)	R.H. nose support (c. c. A-B-C)	Queu support D. (c. c. A-B-C)	Querruderhalterung R (C. F. A-B-C)	Soporte puntal der. (c. c. A-B-C)	
	22	80A0 85778	1	Supporto puntale Dx (codice colore D = 8E36)	R.H. nose support (colour code D = 8E36)	Queu support D. (code couleur D = 8E36)	Querruderhalterung R (code fabre D = 8E36)	Soporte puntal der. (codigo color D = 8E36)	
	22	80B0 85778	1	Supporto puntale Dx (codice colore E F G = 8E63)	R.H. nose support (colour code E F G = 8E63)	Queu support D. (code couleur E F G = 8E63)	Querruderhalterung R (code fabre E F G = 8E63)	Soporte puntal der. (codigo color E F G = 8E63)	
	23	7715 6672B	4	Vite	Screw	Vis	Schraube	Tornillo	
	24	8000 56391	4	Rosetta in nylon	Washer	Rondelle	Scheibe	Arandela	
	25	8000 87600	2	Distanziale	Spacer	Entretoise	Distanzstück	Separador	
	26	60N1 02521	1	Vite	Screw	Vis	Schraube	Tornillo	
	27	62N115549	2	Rosetta	Washer	Rondelle	Scheibe	Arandela	
	28	8000 40719	1	Dado	Nut	Ecrou	Mutter	Tuerca	

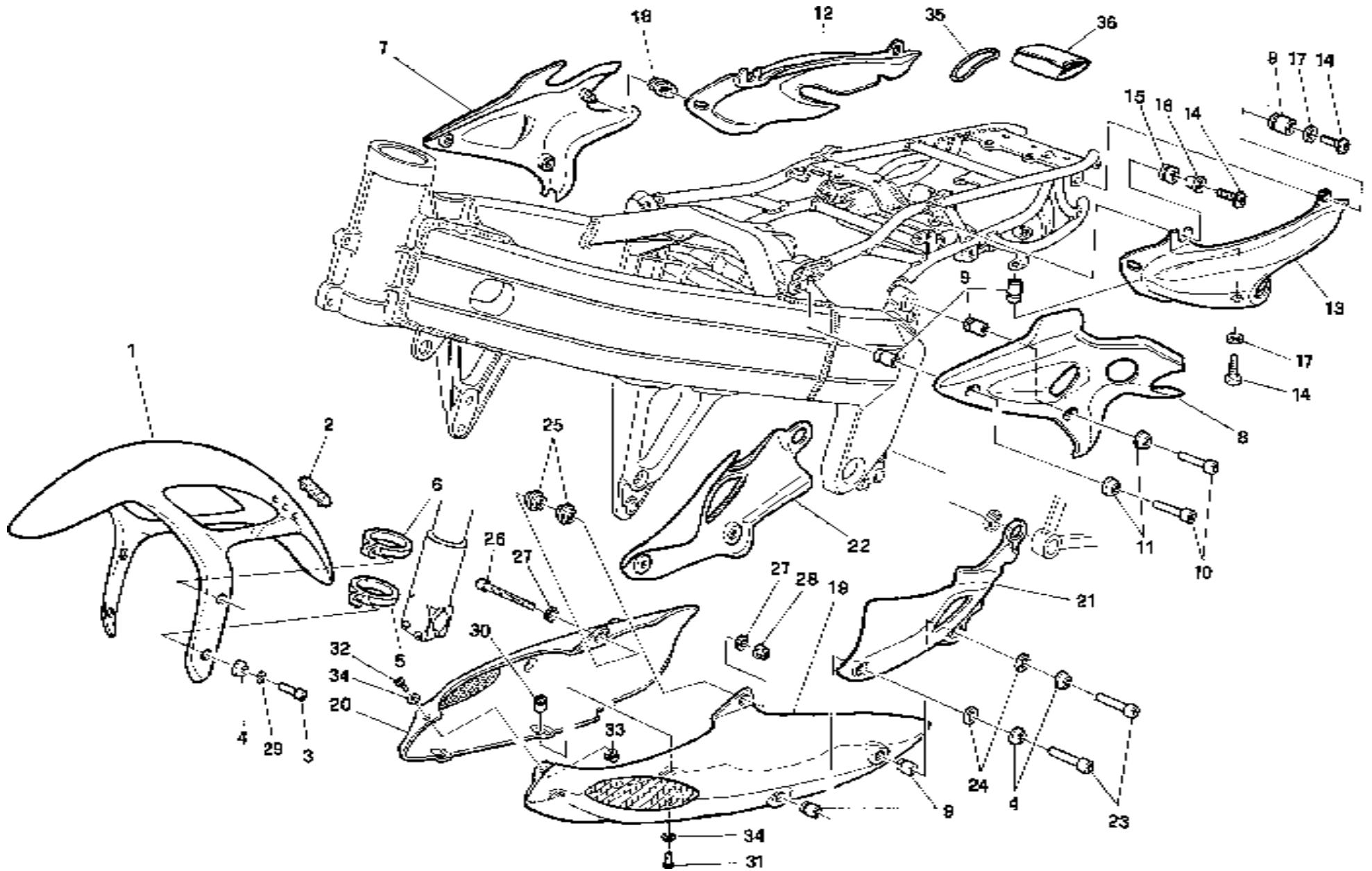

PLANET 125

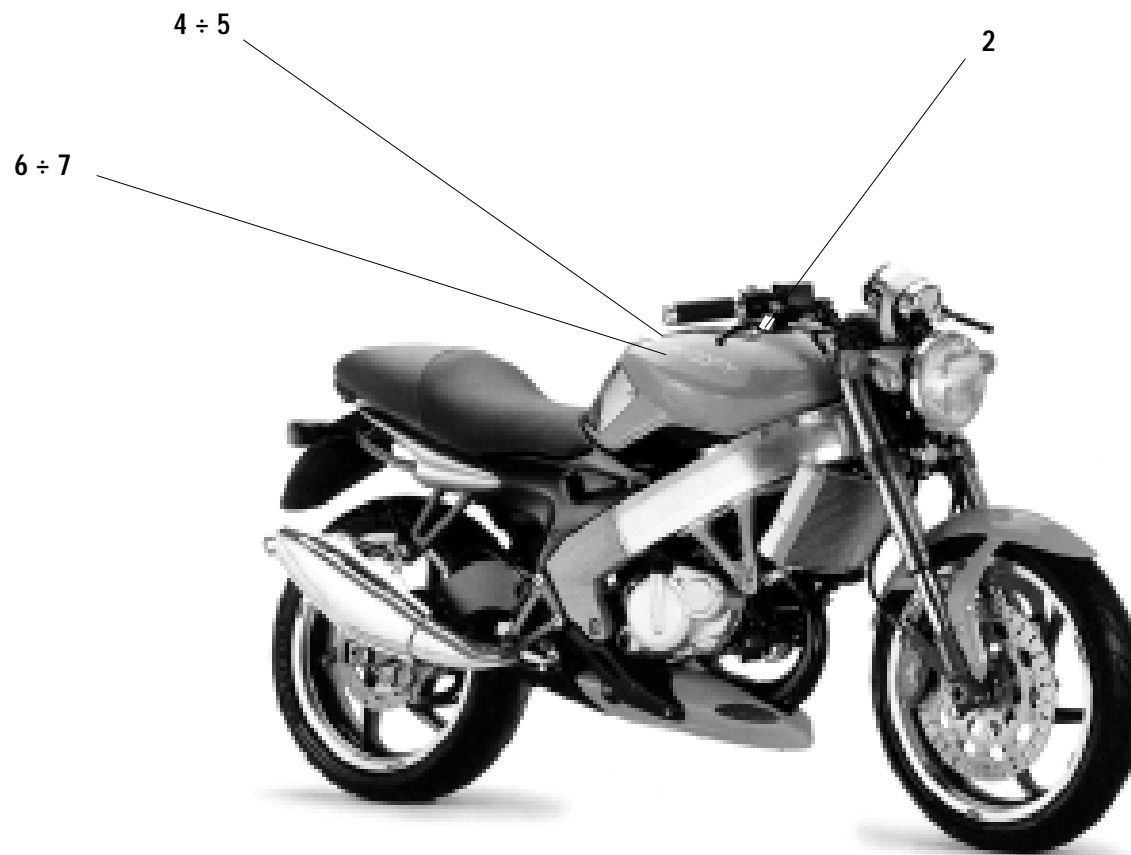
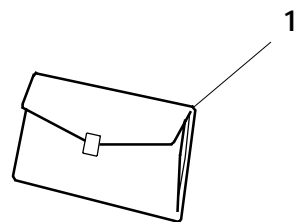

Note Notes Notas	Pos. No. N. Mark Index Pos.	N° Codice Code No. Nr. Code Code Nr. N. Cod.	Q.tà Q.ty Q.te M.ge C.äd	DENOMINAZIONE	NAME	DESIGNATION	BESHREIBUNG	DENOMINACION	Validità Validity Validité Gültig Valides
	1	8000 85786	1	Kit completo (cod. col. A - B - C)	Kit assy (color code A - B - C)	Kit compl. (code col. A - B - C)	Kpl. Kit (cod .Farbe A - B - C)	Juego compl. (cód.col. A - B - C)	
	2	8000 90590	1	Decal informativa	Trim	Décal	Abziehbilder	Calcomanía	
	4	8000 87846	1	Decal. "PLANET" Dx	Trim	Décal	Abziehbilder	Calcomanía	
	5	8000 88161	1	Decal. "PLANET" Sx	Trim	Décal	Abziehbilder	Calcomanía	
	6	8000 88162	1	Decal. "CAGIVA" Dx	Trim	Décal	Abziehbilder	Calcomanía	
	7	8000 87697	1	Decal. "CAGIVA" Sx	Trim	Décal	Abziehbilder	Calcomanía	

PLANET 125

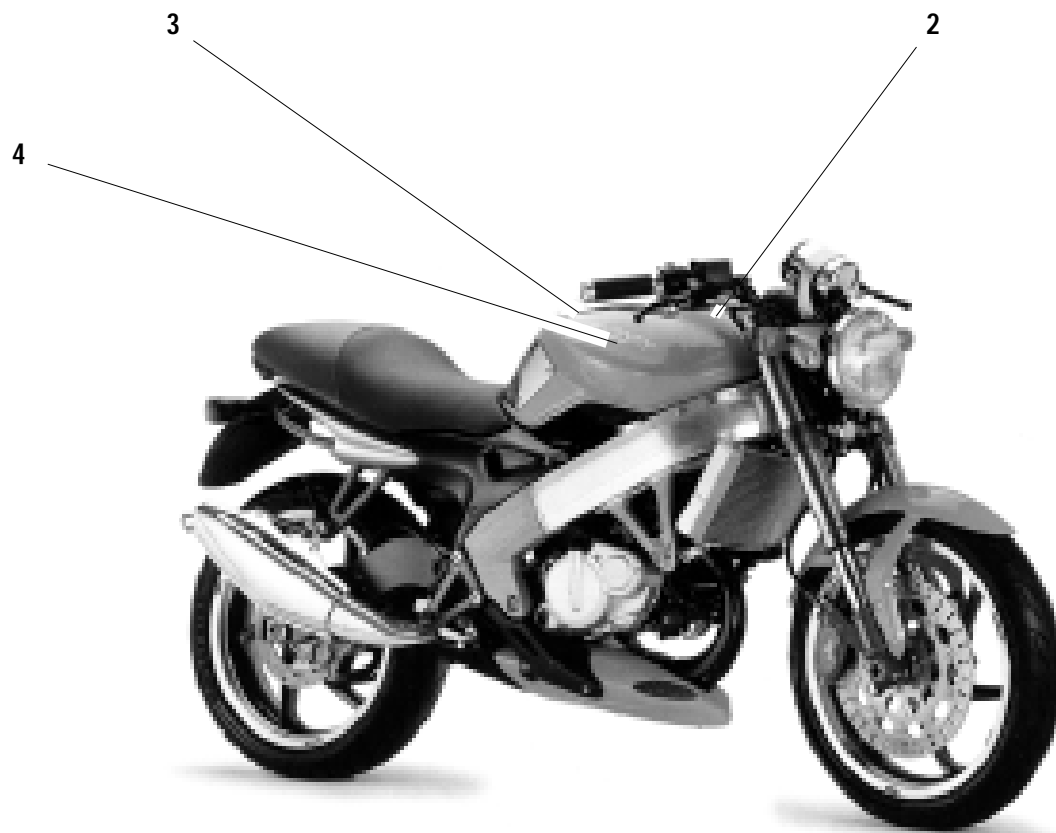
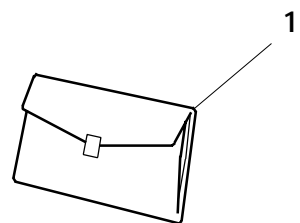

PLANET 125

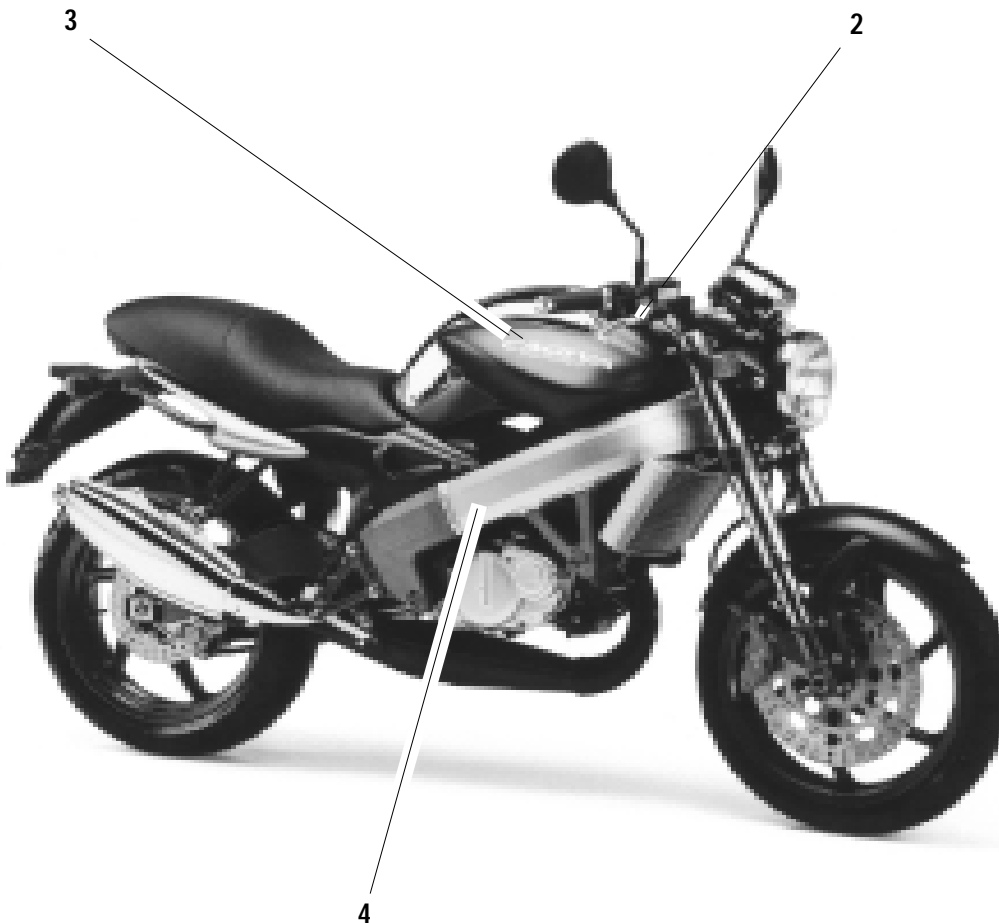
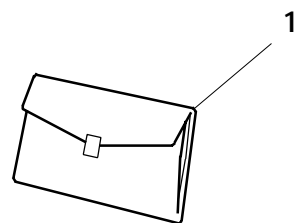

Note Notes Notas	Pos. No. N. Index Pos.	N° Codice Code No. Nr. Code Code Nr N. Cod.	Q.tà Q.ty Q.te M.ge C.ad	DENOMINAZIONE	NAME	DESIGNATION	BESHREIBUNG	DENOMINACION	Validità Validity Validité Gültig Valides
	1	8000 92522	1	Kit completo (cod. col. E)	Kit assy (color code E)	Kit compl. (code col. E)	Kpl. Kit (cod .Farbe E)	Juego compl. (cód.col. E)	
	1	8000 92523	1	Kit completo (cod. col. F)	Kit assy (color code F)	Kit compl. (code col. F)	Kpl. Kit (cod .Farbe F)	Juego compl. (cód.col. F)	
	1	8000 92524	1	Kit completo (cod. col. G)	Kit assy (color code G)	Kit compl. (code col. G)	Kpl. Kit (cod .Farbe G)	Juego compl. (cód.col. G)	
	2	8000 90590	1	Decal informativa	Trim	Décal	Abziehbilder	Calcomanía	
	3	8000 92378	2	Decal "PLANET"(cod. col. E H L)	Trim (color code E H L)	Décal (code col. E H L)	Abziehbilder (cod .Farbe E H L)	Calcomanía (cód.col. E H L)	
	3	80A0 92378	2	Decal. "PLANET" (cod. col. F)	Trim (color code F)	Décal (code col. F)	Abziehbilder (cod .Farbe F)	Calcomanía (cód.col. F)	
	3	80B0 92378	2	Decal. "PLANET" (cod. col. G)	Trim (color code G)	Décal (code col. G)	Abziehbilder (cod .Farbe G)	Calcomanía (cód.col. G)	
	4	8000 92377	2	Decal. "High Frame Technology" (cod. col. E)	Trim (color code E)	Décal (code col. E)	Abziehbilder (cod .Farbe E)	Calcomanía (cód.col. E)	
	4	80A0 92377	2	Decal. "High Frame Technology" (cod. col. F)	Trim (color code F)	Décal (code col. F)	Abziehbilder (cod .Farbe F)	Calcomanía (cód.col. F)	
	4	80B0 92377	2	Decal. "High Frame Technology" (cod. col. G)	Trim (color code G)	Décal (code col. G)	Abziehbilder (cod .Farbe G)	Calcomanía (cód.col. G)	